



Embedded Display System

With

CAN Bus

Product Information

(Temporary)

MODEL NO. : CES035Q1-FA9201 v.1

Date : 2009/02/23 Revision.0.3

Prepared by : Nicholas Shih

Nicholas Shih, Engineer, Product Development Div.

Approved by : Jackey Chien

Jackey Chien, Director, Product Development Div.

This Embedded Display System is distributed by:



Display Solution AG
Talhofstraße 32a
D-82205 Gilching
GERMANY
Fon +49 (0)8105 / 73 403 - 0
Fax +49 (0)8105 / 73 403 - 79
E-Mail: info@display-solution.com
Internet: www.display-solution.com

This product specification is subject to change without any notice.



Records of Revision

Date	Rev. No.	Summary	Page
2008/11/10	0.1	First issue	
2009/02/10	0.2	Outline dimensions changed	6,7,14
		Pin Assignment Changed	12,14
2009/2/23	0.3	Major Change on Outline Dimensions	7,14



Contents		Page
1.0 Handling Precautions	-----	4
2.0 General Description	-----	5
2.1 General Application	----- 6	
2.2 Main Features	----- 6	
2.3 General Information	----- 6	
2.3.1 Display Characteristics	----- 6	
2.3.2 Mechanical Dimensions	----- 7	
3.0 Absolute Maximum Ratings	-----	8
3.1 Absolute Ratings of Environment Requirement	----- 8	
3.2 Electrical Absolute Ratings	----- 8	
3.2.1 Entire Embedded System	----- 8	
4.0 Optical Characteristics	-----	9
5.0 Electrical Characteristics	-----	12
5.1 DC Characteristics	----- 12	
5.1.1 Entire Embedded System	----- 12	
5.2 Input Terminal Pin Assignment	----- 12	
5.2.1 Interface Connector	----- 12	
6.0 Display Pixel Format	-----	13
7.0 Outline Dimensions	-----	13
8.0 Labeling, Packaging & Others	-----	15
9.0 General Notices	-----	16
9.1 Storage	----- 16	
9.2 Operation & Others	----- 17	



1.0 Handling Precaution

- 1.) Handle with care. Pay attention not to press or scratch the surface of the system screen, especially the polarizer. Do not twist or bend the whole module or any part of the system kit. It may cause un-recoverable damages to the system.
- 2.) Do not drop or bump the system kit since the LCD display of the asystem contains fragile glass components. Breakage of this portion might cause leakage of the liquid crystal sealed inside the displays. Do not touch the liquid crystal liquid in case of leakage. Flush with massive water immediately in case of contact with your skin with liquid crystal fluid and call for doctor for immediate medical treatment.
- 3.) Be sure to turn off power supply while plug or un-plug the power input connector.
- 4.) Clean up the polarizer only with soft solvent if necessary. The desirable cleaners are water, IPA(Isopropyl Alcohol) or Hexane. Do not use Ketone type materials (ex. Acetone), Ethyl alcohol, toluene, Ethyl acid or Methyl chloride. It will permanently damage the polarizer due to chemical reaction. 5.) Wipe off fluid drop immediately to prevent from possible discoloration or spots on the polarizer.
- 6.) Do not twist nor bend the system structure, even momentarily. Bending or twisting torque may likely damage the internal components of the system.
- 7.) The cold cathode fluorescent lamp in LCD contains small amount of mercury (Hg). Please refer to the design specification for application and the local regulations and environmental laws for disposal purpose.
- 8.) Protect the system from static environment to prevent from damage to the CMOS gate array IC.



2.0 General Description

CES035Q1-FA9021 v.1 series is a very compact, highly integrated ARM9 embedded system that is consist of the following components.

1. 3.5" QVGA (320x240) digital TFT LCD display
2. Sunlight readable brightness, 800 nits
3. Embedded Solution with a FreeScale MC9328MXS, ARM9 based embedded CPU board
4. Built-in 64MB SDRAM and 16MB flash memory
5. PowerView own OS platform Ready
6. IP-67 Plastic Housing
7. Module Connector Housing Adopted with Deutsch DT06-12SA Connector
8. Touch Screen Version in option

CES035Q1-FA9201-3 v.1 is a complete all-in-one embedded system that provides a ready-to-use environment for customers with a variety of applications. Its compact, power-saving computing circuitry and slim LCD modules make the whole system very suitable for portable, diagnostic and HMI(Human Machine Interface) applications. Its housing design also meets IP-65 standard that enables users to operate this monitor in various environment. With its industrial standard function-ready and built-in PowerView owned OS software, CES035Q1-FA9201-3 v.1 provides an easy-to-use, robust, installation-ready and risk-less environment for all users. Customers can concentrate their major engineering resources on the application software development for specific application.

In addition, another special merit of CES035Q1-FA9201-3 v.1 is its true digital TFT LCD display. With 3.5" in diagonal size, QVGA 320x240 resolution, and 800 nits(typ.) sunlight readable brightness, its very vivid, eye-catching and crystal clear screen can perfectly present excellent pictures, icons, user interface on its 4:3 TFT screen. Everything needed for a computing display is already built into a compact and complete module and ready for immediate installation upon arrival.

The platform of CES035-FA9201-3 v.1 also reserves high flexibilities to adopt future expansions of several different industrial interfaces without changing its original form factor. This merit can minimize the reinvestments of capital and engineering efforts in remaking mechanical tooling for specification changes.

There is a graphic drawing utility available, which is developed by Powerview to let customer control this embedded system by using the ASCII command code via RS232 interface. With the help of this graphic utility, customer can easily develop their own application software without the complex programming skill which usually is needed by the other embedded systems on the market.



2.1 General Applications

- Portable Devices, Compact Diagnostic Tools, Surveillance and Monitoring Equipment, Control and HMI Terminals

2.2 Main Features

- All-IN-ONE unit with Single DC power Supply Input
- Embedded ARM9 MCU Engine
- Low Power Consumption with Sunlight Readable Brightness
- Versatile I/O functions
- Auxiliary GPIOs Available
- Built-in Digital 3.5" LCD
- Built-in DC-DC for TFT and LED driver for LED backlight
- Compact, Thin and Light Weight
- IP-67 Level Housing Protection
- PowerView Proprietary OS Ready
- Generic Drawing Utility Available for Easy Application Software Development

2.3 General Information

2.3.1 System & Display Characteristics

Item	Specification	Unit	Note
Total System			
CPU Processor	MC9328MXS, FreeScale's ARM9 MCU	-	-
OS	PowerView Proprietary OS	-	
Flash Memory	16 MB	-	
SDRAM	64 MB	-	
Communication I/F	RS232 / or RS485 (optional) x 1 , CAN Bus 2.0B x 1 USB1.1 Client x 1(for f/w upload)	-	Note (1)
DC power input	+10V~+32V	V	
Outline Dimensions	95.0 x 95.0 x 43.8	mm	
User interface	Keypad (5 keys)		
Protection	IP67		
IO Connector	Deutsch DT04-12PA 12 way Compatible		
Audio Alarm	Optional		
EMC	(Meets the requirements of European Directive 89.336/EC using methods and limits defined in BSEN 60945)		
Salt-Spray	(Tested by 28 days at 40°C and 93%)		



Display Unit			
Display Type	a-Si TFT LCD 3.5" (diagonal size)	inch	4:3
Active Area	70.08(H) x 52.56(V)	mm	-
Number of Pixels	320 (H) x 240(V)	pixel	QVGA
Pixel Arrangement	RGB Vertical Stripe	-	-
Brightness	800	cd/m ²	
Viewing Angle	130/110	degree	6 o'clock
Display Mode	Normally White	-	-
Color Depth	262K colors -- LCD 64K colors -- System		64 K colors

Note (1) Customer's program code could be updated via the USB client port. .

2.3.2 Mechanical Dimensions

Item		Min.	Typ.	Max.	Unit	Note
Dimension	Horizontal	-	111.9	-	mm	±0.5
	Vertical	-	111.9	-		±0.5
	Depth	-	23.0	-		Main Body, (1)
	Depth		43.8			Incl. CN Housing
Weight		-	190	-		±10g(temp)

Note (1) This depth exists excluding the compatible connector housing of the Deutsch Connector DT04-12xx series.



3.0 Absolute Maximum Ratings

3.1 Absolute Ratings of Environment Requirement

Item	Symbol	Min.	Max.	Unit	Note
Storage Temperature	Tstg	-30	+80	°C	(1)
Operation Temperature (Ambient Temperature)	Topr	-20	+70	°C	(1)

Note (1) Temperature and relative humidity range are shown in the figure below.

95% RH Max. ($40^{\circ}\text{C} > T_a$)

Maximum wet – bulb temperature at 39°C or less. ($T_a > 40^{\circ}\text{C}$) No condensation.

3.2 Electrical Absolute Ratings

3.2.1 Entire Embedded Module

Item	SYMBOL	MIN	MAX	UNIT	NOTE
Power Supply Voltage	VDD	-0.3	38	V	(1),(2)

Note (1) Within operating temperature

Note (2) Permanent damage to the device may occur if maximum values are exceeded.

Functional operation should be restricted to the conditions described under normal operating conditions.



4.0 Optical Characteristics of Display

The following items are measured under stable conditions in a dark room or equivalent state.

4.1 Measuring Equipment: BM-5A, PR-650

($V_{DD}=1.2V$, $f_V=60Hz$, $f_H=15.734KHz$, $T_a=25\pm 2^\circ C$)

Item	Symbol	Condition	Min.	Typ.	Max.	Unit	Note
Contrast Ratio	CR	$\Phi=0$ $\theta=0$ Viewing Normal Angle	200	300	-		BM-5A (4)-[1]
Response Time at 25°C	Rising	T_R	-	15	-	ms	BM-5A (5)
	Falling	T_F	-	20	-		
Luminance	Y_L			800	-	Cd/m ²	BM-5A (4)-[2]
Viewing Angle	Hor.	Θ_L	CR \geq 10(at center point)		65	Degree	BM-5A (7)
		Θ_R			65		
	Ver.	Θ_H			65		
		Θ_L			45		

Note (1) The optical characteristics is measured with backlight.

Note (2) If product is exposed to high temperatures for extended time, there is a possibility of the polarizer file damage which could degrade the optical characteristics.

Note (3) Test Equipment Setup

After leaving the panel alone at a given temperature for 30 minutes under a stable condition, the measurement should be executed. Measurement should be executed in a stable, windless and dark room over 30 minutes after the backlight is lighted up.

The measuring point should be at the center of screen.

-Environment condition : $T_a=25\pm 2^\circ C$

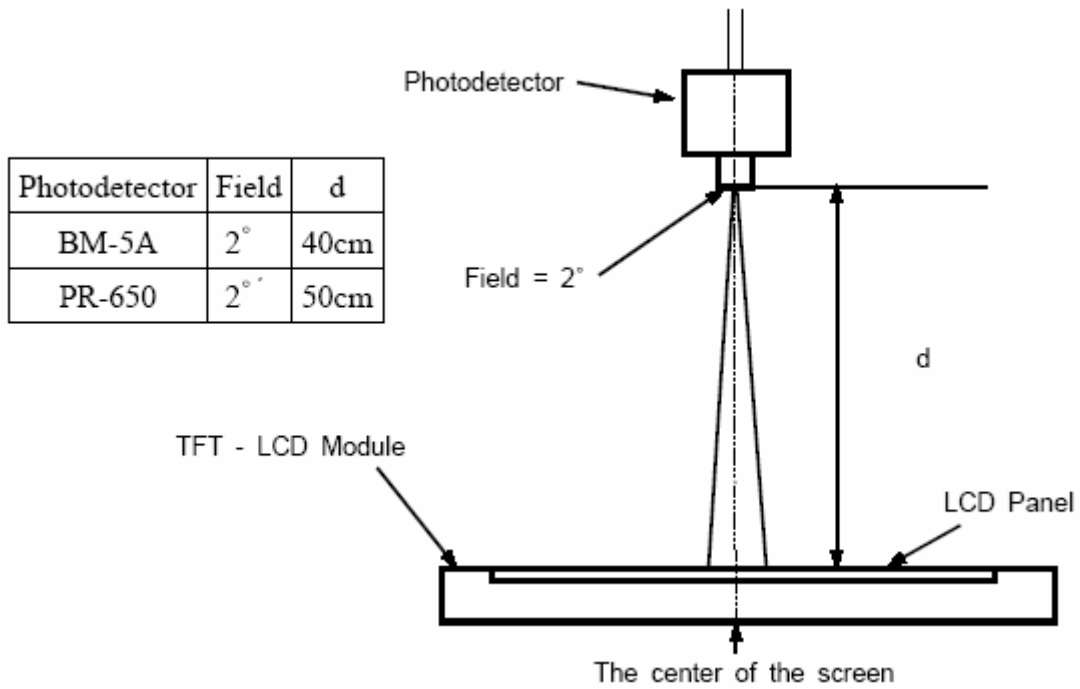

Note (4) Definition of Contrast Ratio, Luminance

ACTIVE AREA (H:101.76mm/ V:76.36mm)

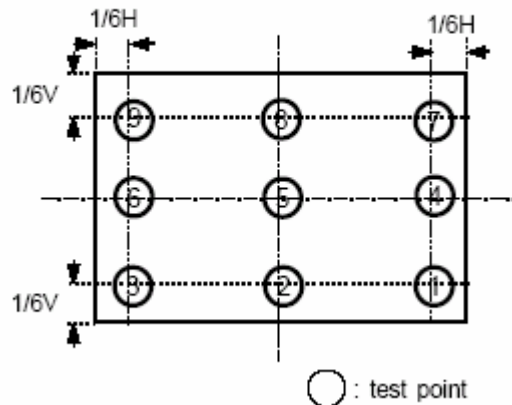

[1] Definition of Contrast Ratio (CR) : Ratio of gray max (G_{max}), gray min (G_{min}) at 9 points.

$$C/R = G_{max}/G_{min}$$

G_{max} : Luminance with all pixels white

G_{min} : Luminance with all pixels black

[2] Definition of Luminance : measure the luminance of white at center point and with maximum brightness.

Note (5) Definition of Response Time : Sum of T_r and T_f.

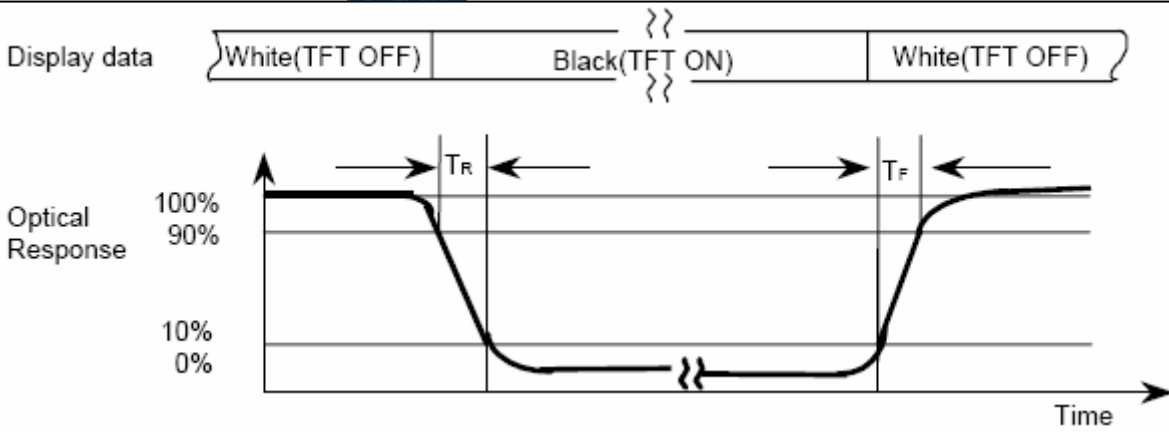

Note (6) Definition of Color Chromaticity (CIE 1931), (Backlight : ON) :
Color coordinate of white at the center point

Note (7) Definition of Viewing Angle : Viewing angle range ($CR \geq 10$)

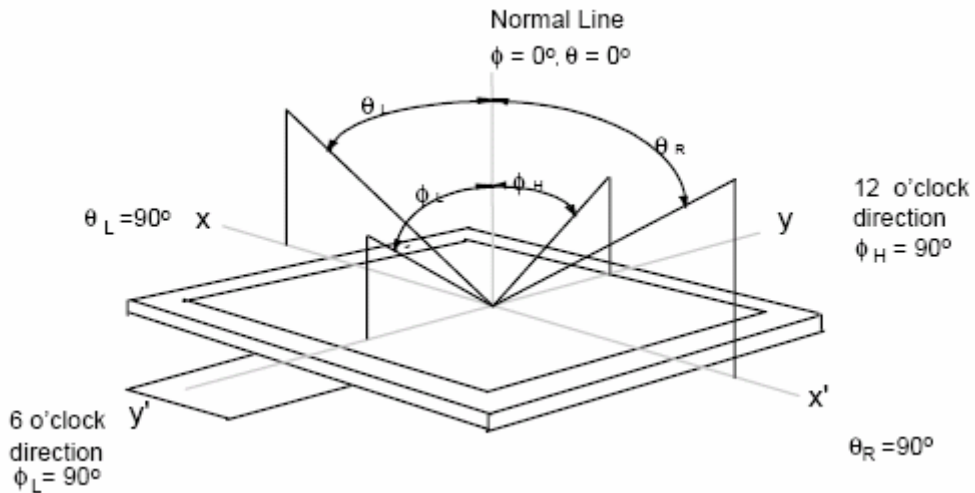



5.0 Electrical Characteristics

5.1 DC Characteristics

5.1.1 Entire Embedded System

Item	Symbol	Min.	Typ.	Max.	Unit	Note
Supply Voltage	V _{DD}	10	12	32	V	
	I _{DD}	-	(250)		mA	Note 1
Permissive Input Ripple Voltage	V _{RF}	-	-	100	mV _{P-P}	V _{DD} =+12V

Note 1: V_{DD}=12V Without RS232, RS485, or CAN2.0B device connected (LCD is attached, with the maximum brightness).

5.2 Input Terminal Pin Assignment

5.2.1 Interface Connector

Connector: Deutsch 12 pin DT0412PA or equivalent

Pin No.	Symbol	Description	Remark
1	GND	Power Ground	
2	VDD	DC Power input.	
3	USB_DC5V	+5V DC input for USB Power	
4	USB_CN	USB Client Negative Pin	
5	USB_CP	USB Client Positive Pin	
6	GND	Ground	
7	CAN_L	CAN2.0B Negative Pin.	
8	CAN_H	CAN2.0B Positive Pin	
9	RS485_L	RS485 Negative Pin (or RS232 Tx)	
10	RS485_H	RS485 Positive Pin (or RS232 Rx)	
11	RS232_B TX	RS232 Negative Pin	
12	RS232_B RX	RS232 Positive Pin	



6.0 Display Pixel Format

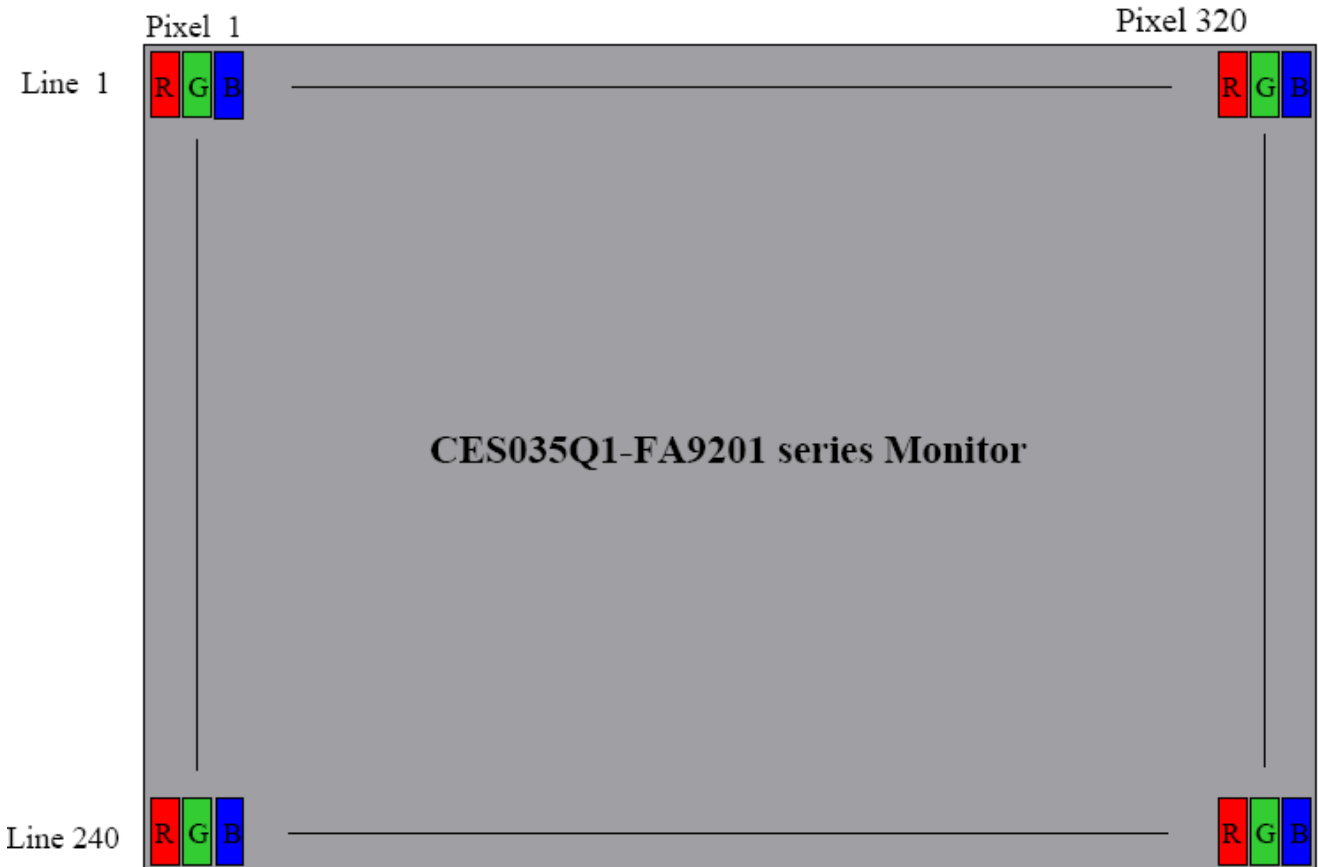

7.0 Outline Dimensions

8.1 Monitor Outline Dimensions

- Please refer to the next page



8.0 Labeling, Packaging & Others

* Labeling

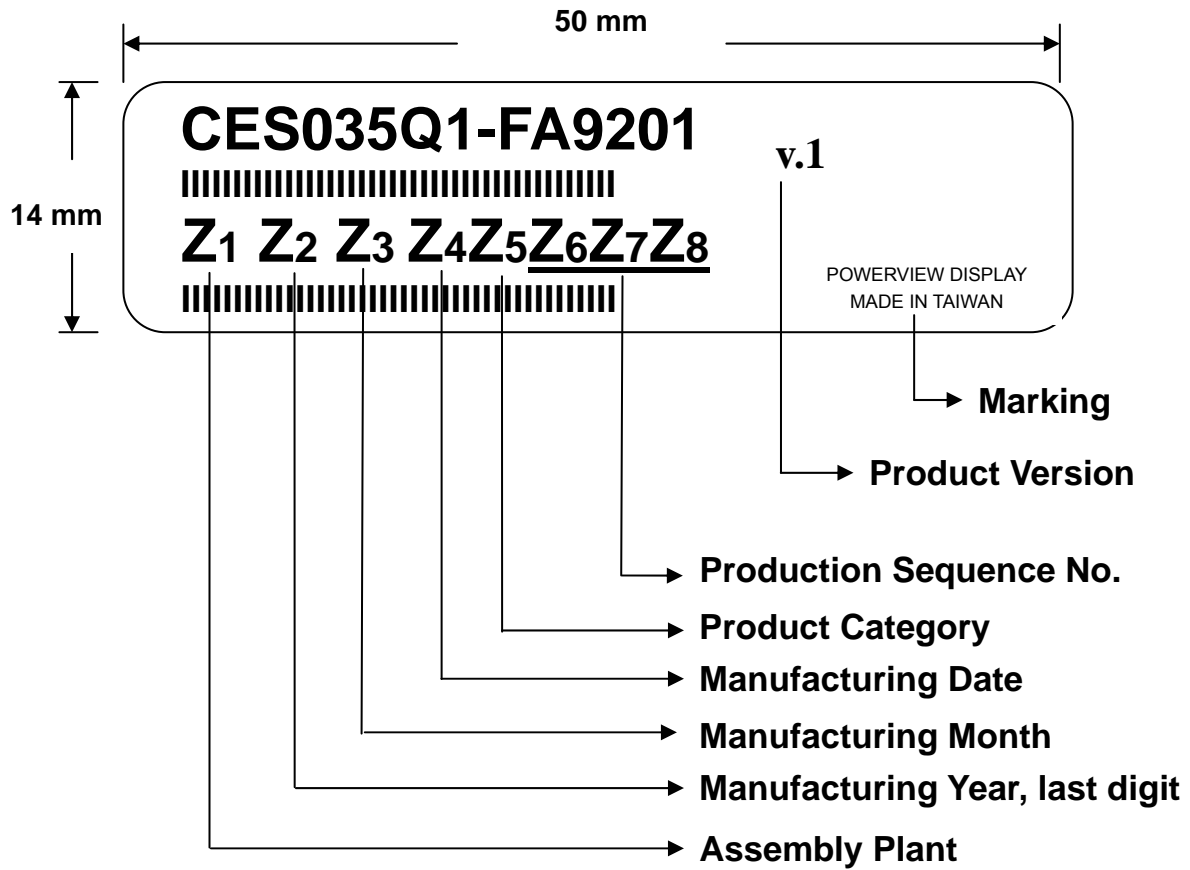

* Packaging

- TBD

* Others



9.0 General Notice

9.1 Reliability Test Items (Note 2)

No.	Test Items	Conditions	Remark
1	High Temperature Storage	Ta= + 80°C 240 Hrs	
2	Low Temperature Storage	Ta= - 30°C 240 Hrs	
3	High Temperature Operation	Ta= + 70°C 240 Hrs	
4	Low Temperature Operation	Ta= - 20°C 240 Hrs	
5	High Temperature and High Humidity	Tp= 60°C, 90%RH 240 Hrs	operation
6	Heat Shock	-40~90°C/200 cycles 1Hr/cycle	Non-operation
7	Electrostatic discharge	±200V, 200pF(0Ω), once for each terminal	Non-operation
8	Vibration	Frequency range : 8~33.3 Hz Stoke : 1.3mm Sweep : 2.9G, 33.3~400Hz Cycle : 15 minutes 2 hours for each direction of X,Z 4 hours for Y direction	JIS C7021, A-10 Condition A
9	Mechanical Shock	100G, 6ms, ±X±Y±Z 3 times for each direction	JIS C7021, A-7 Condition C
10	Vibration (with carton)	Random vibration : 0.015G ² /Hz from 5~200Hz -6dB/octave from 200~500Hz	IEC 68-34
11	Drop (with carton)	Height : 60 cm 1 corner, 3 edges, 6 surfaces	JIS Z0202

Note1: Ta: Ambient temperature.

Note 2: In the standard conditions, there is not display function NG issue occurred. All the cosmetic specification is judged before the reliability stress.



9.2 Storage, Operation & Others

- (a) Do not leave the panel in high temperature, and high humidity for a long time.
It is highly recommended to store the module with temperature from 0 to 35°C and relative humidity of less than 70%.
- (b) Do not store the TFT-LCD module in direct sunlight.
- (c) The module shall be stored in a dark place. It is prohibited to apply sunlight or fluorescent light during the store.
- (d) Do not connect, disconnect the module in the "Power On" condition.
- (e) Power supply should always be turned on/off by the item 3.2 "Electrical Absolute Ratings"
- (f) The liquid-crystal is deteriorated by ultraviolet rays. Do not leave it in direct sunlight and strong ultraviolet rays for many hours.
- (g) Avoid condensation of water. It may result in improper operation or disconnection of electrode.
- (h) Do not exceed the absolute maximum rating value. (the supply voltage variation, input voltage variation, variation in part contents and environmental temperature, and so on) Otherwise the panel may be damaged.
- (i) If the panel displays the same pattern continuously for a long period of time, it can be the situation when the image "Sticks" to the screen.
- (j) This panel has its circuitry FPC on the bottom side and should be handled carefully in order not to be stressed.