



ELECTRONICS

Approval

To : General
Date : 2005-02-14

SAMSUNG TFT-LCD
MODEL NO. : LTM150XO-L01

Approved by :

Any Modification of Spec is not allowed without SEC's permission.

Senior Manager : 

PREPARED BY : LCD Business Technical Customer Service Team

Samsung Electronics Co . , LTD.



Contents

Revision History	-----	(3)
General Description	-----	(4)
1. Absolute Maximum Ratings	-----	(5)
1.1 Absolute ratings of environment		
1.2 Electrical Absolute Ratings		
2. Optical Characteristics	-----	(7)
3. Electrical Characteristics	-----	(11)
3.1 TFT LCD Module		
3.2 Back-light Unit		
4. Block Diagram	-----	(14)
4.1 TFT LCD Module		
4.2 Back-light Unit		
5. Input Terminal Pin Assignment	-----	(15)
5.1 Input Signal & Power		
5.2 LVDS Interface		
5.3 Back-light Unit		
5.4 Pixel Format		
5.5 Input Signals, Basic Display Colors and Gray Scale of Each Color		
6. Interface Timing	-----	(19)
6.1 Timing Parameters (DE only mode)		
6.2 Timing Diagrams of Interface Signal (DE only mode)		
6.3 Power ON/OFF Sequence		
7. Outline Dimension	-----	(22)
8. Reliability Test	-----	(24)
9. Packing	-----	(25)
10. Marking & Others	-----	(26)
11. Inspection Criteria	-----	(27)
12. General Precaution	-----	(29)
12.1 Handling		
12.2 Storage		
12.3 Operation		
12.4 Others		

*** Revision History**

Approval

Date	Rev. No	Page	Summary
Feb. 14, 2005	P00	All	Approval specification of LTM150XO-L01 model was issued first.

*** Description**

LTM150XO-L01 is a color active matrix TFT (Thin Film Transistor) liquid crystal display (LCD) that uses amorphous silicon TFTs as switching devices. This model is composed of a TFT LCD panel, a driver circuit and a back-light system. The resolution of a 15.0" contains 1024 x 768 pixels and can display up to 16.2 millions colors.

*** Features**

- High contrast ratio, high aperture structure
- TN (Twisted Nematic) mode
- Wide viewing angle
- High speed response
- XGA (1024 x 768 pixels) resolution
- Low power consumption
- 2 CCFTs (Cold Cathode Fluorescent Tube)
- DE (Data Enable) mode
- LVDS (Low Voltage Differential Signaling) interface (1pixel/clock)
- Compact Size Design

*** Applications**

Desktop monitors

Display terminals for AV application products

Monitors for industrial machine

* If the module is used to other applications besides the above, please contact SEC in advance.

*** General information**

Items	Specification	Unit	Note
Display area	304.128(H) x 228.096(V)	mm	
Driver element	a-Si TFT active matrix		
Display colors	16.2M	colors	
Number of pixels	1024 x 768	pixel	
Pixel arrangement	RGB vertical stripe		
Pixel pitch	0.297(H) x 0.297(W)	mm	
Display mode	Normally White		
Surface treatment	Haze 25%, Hard-coating (3H)		

* **Mechanical information**

Item		Min.	Typ.	Max.	Note
Module size	Horizontal(H)	326.0	326.5	327.0	mm
	Vertical(V)	253.0	253.5	254.0	mm
	Depth(D)	-	-	12.0	mm
Weight		-	-	1,150	g

1. Absolute Maximum Ratings

1.1 Absolute ratings of environment

Item	Symbol	Min.	Max.	Unit	Note
Storage temperature	T _{STG}	-25	60		(1)
Operating temperature (Glass surface temperature)	T _{OPR}	0	50		(1)
Shock (non - operating)	Snop	-	50	G	(2),(4)
Vibration (non - operating)	Vnop	-	1.5	G	(3),(4)

Note (1) Temperature and relative humidity range are shown in the figure below.

90 % RH Max. ($40\text{ }^{\circ}\text{C} \geq T_a$)

Maximum wet-bulb temperature at $39\text{ }^{\circ}\text{C}$ or less. ($T_a > 40\text{ }^{\circ}\text{C}$) No condensation.

(2) 11ms, sine wave, one time for $\pm X$, $\pm Y$, $\pm Z$ axis

(3) 10-300 Hz, Sweep rate 10min, 30min for X,Y,Z axis

(4) At vibration and shock test, the fixture which holds the module to be tested has to be hard and rigid enough so that the module would not be twisted or bent by the fixture.

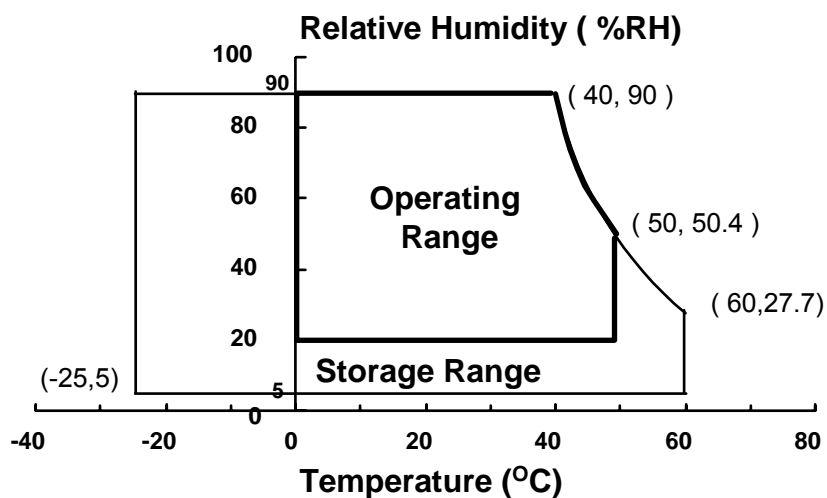

1.2 ELECTRICAL ABSOLUTE RATINGS

(1) TFT LCD Module

(V_{ss} = GND = 0 V)

Item	Symbol	Min.	Max.	Unit	Note
Power Supply Voltage	VDD	V _{ss} -0.3	4.0	V	(1)

Note (1) Within Ta (25 ± 2 °C)

(2) BACK-LIGHT UNIT

(Ta = 25 ± 2°C)

Item	Symbol	Min.	Max.	Unit.	Note
Lamp Current	IL	3.0	9.0	mArms	(1),(2)
Lamp Frequency	fL	40	80	kHz	(1)

Note (1) Permanent damage to the device may occur if maximum values are exceeded. Functional operation should be restricted to the conditions described under Normal Operating Conditions.

(2) Specified values are for a single lamp.

(Refer to the Note (1) in the page 13 for further information).

2. Optical Characteristics

Approval

The following items are measured under stable conditions. The optical characteristics should be measured in a dark room or equivalent state with the methods shown in Note (1).

Measuring equipment : TOPCON BM-5A, BM-7, PHOTO RESEARCH PR650
Eldim EZ-Contrast

(Inverter Freq. : 50 kHz) * Ta = 25 ± 2°C, VDD=3.3V, fv= 60Hz, fDCLK=65MHz, IL = 8.0mA_{rms}

Item		Symbol	Condition	Min.	Typ.	Max.	Unit	Note	
Contrast Ratio (Center of screen)		C/R	Normal $\phi = 0$ $\theta = 0$ Viewing Angle	350	450	-		(3) BM-5A	
Response Time	Rising	Tr		-	2.5	5	msec	(5) BM-7	
	Falling	Tf		-	9.5	15			
Luminance of White (Center of screen)		YL			200	250	-	cd/m ²	(6) BM-5A
Color Chromaticity (CIE 1931)	Red	Rx			0.602	0.632	0.662		(7) PR650
		Ry			0.323	0.353	0.383		
	Green	Gx			0.267	0.297	0.327		
		Gy			0.551	0.581	0.611		
	Blue	Bx			0.114	0.144	0.174		
		By			0.077	0.107	0.137		
	White	Wx		0.283	0.313	0.343			
		Wy		0.299	0.329	0.359			
Viewing Angle	Hor.	θ L	CR _≥ 10	55	65	-	Degrees	(8) BM-5A	
		θ R		55	65	-			
	Ver.	ϕ H		40	50	-			
		ϕ L		50	60	-			
Brightness Uniformity (9 Points)		Buni		-	-	25	%	(4) BM-5A	

Note (1) Test Equipment Setup

The measurement should be executed in a stable, windless and dark room between 30min and 40min after lighting the back-light at the given temperature for stabilization of the back-light. This should be measured in the center of screen.

Single lamp current : 8.0mA (Refer to the note(1) in the page 13 for more information.)

Environment condition : $T_a = 25 \pm 2 \text{ }^\circ\text{C}$

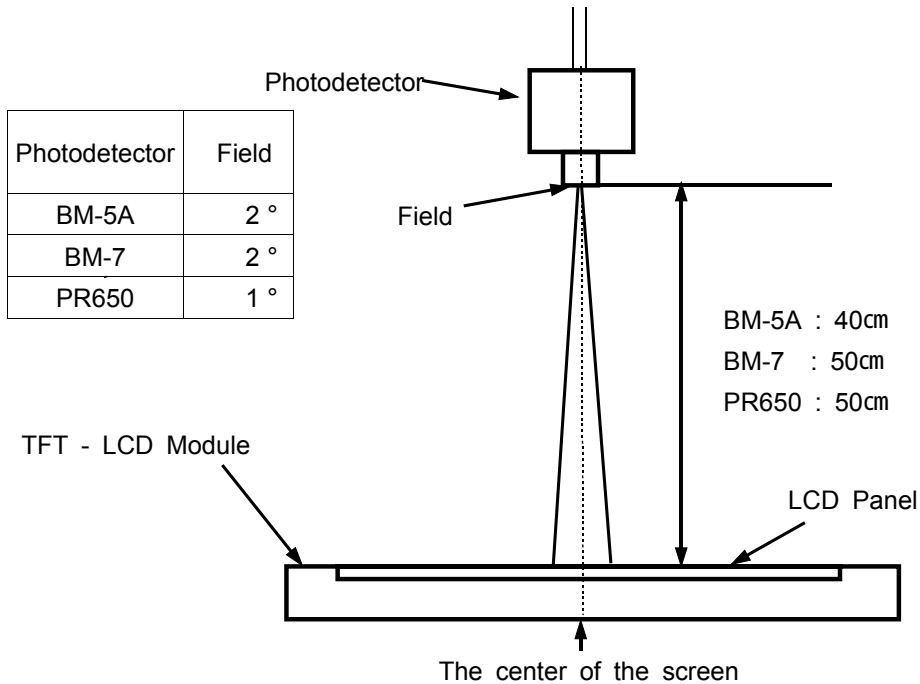

Optical Measuring Equipment Setup

Note (2) Definition of test point

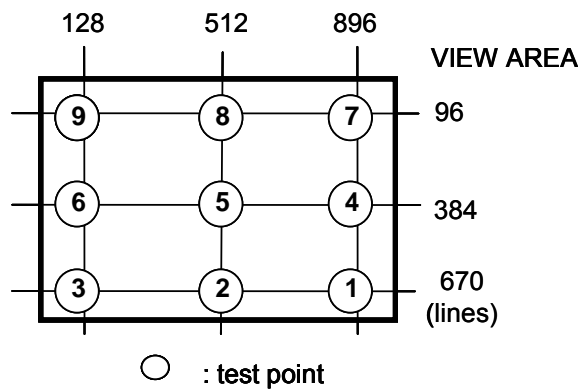

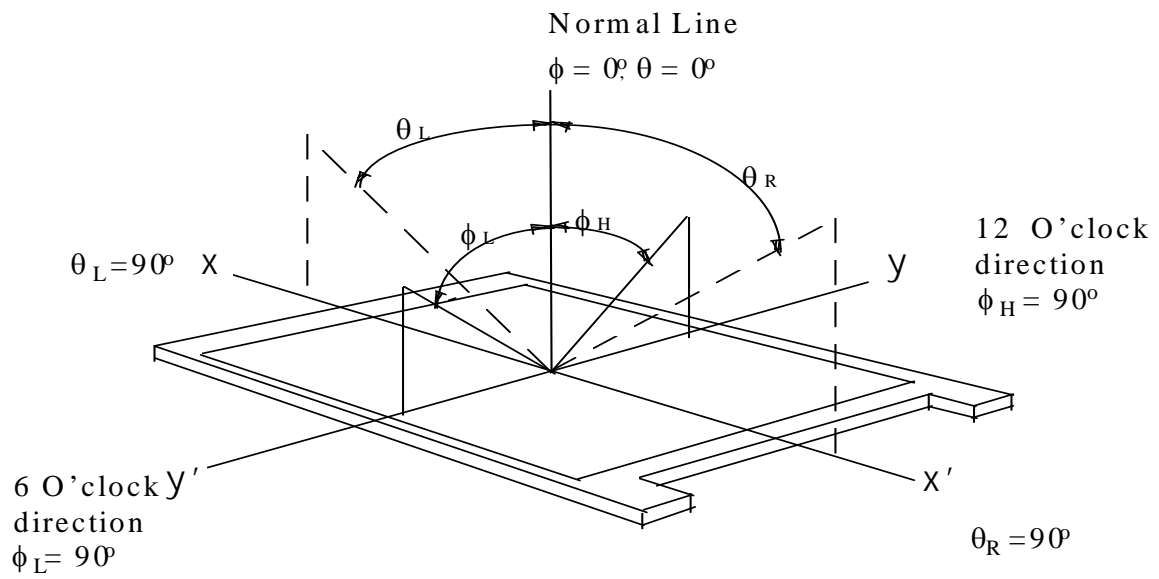

3. Electrical Characteristics

3.1 TFT LCD MODULE

Ta = 25°C

ITEM	SYMBOL	MIN.	TYP.	MAX.	UNIT	NOTE
Power Supply Voltage	VCC	3.0	3.3	3.6	V	(1)
Differential Input Threshold Voltage	VH	-	-	+100	mV	VCM =1.2V
	VL	-100	-	-	mV	
Power Consumption	(a) White	-	450	-	mA	(2),(3)
	(b) Black	-	500	-	mA	
	(c) Dot	-	550	700	mA	
Vsync Frequency	fV	59	60	75	Hz	-
Hsync Frequency	fH	47.6	48.4	62	KHz	
Main Frequency	fDCLK	64	65	80	MHz	
Rush Current	IRUSH	-	-	3.0	A	(5)

Note (1) The connector for display data & timing signal should be connected.(Vss=0V)

(2) fV = 60Hz, fDCLK = 65MHz, VDD = 3.3V, DC Current.

(3) Power dissipation check pattern(LCD Module only)

a) Black Pattern

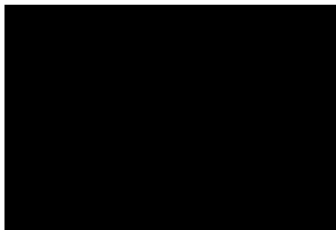

b) White Pattern



c) Dot Pattern

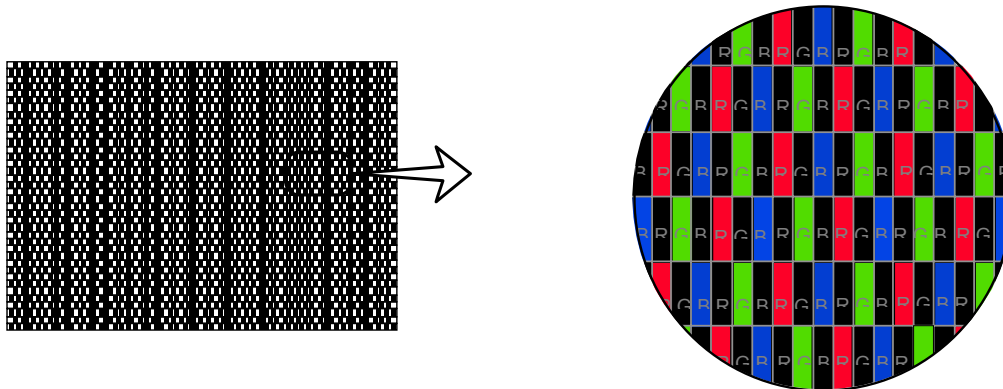

(4) Measurement Conditions

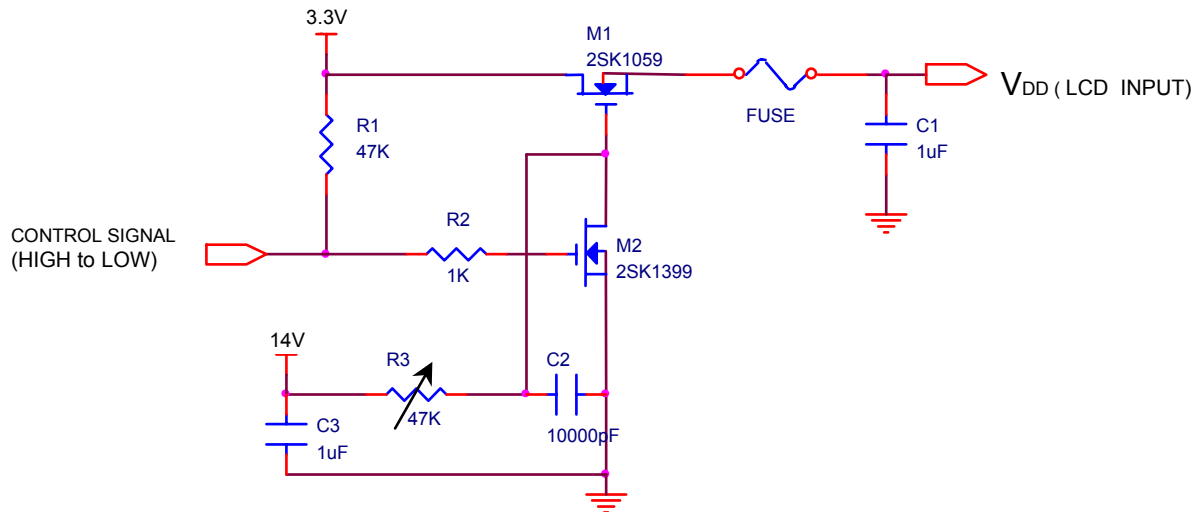

Control Signal : High(+3.3V) → Low(Ground)

All Signal lines to panel, except for power 3.3V : Ground

The rising time of supplied voltage is controlled to 470us by R3 and C2 value.

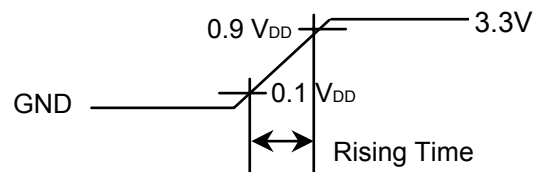

3.2 BACK-LIGHT UNIT

The back-light system is an edge - lighting type with a dual CCFT (Cold Cathode Fluorescent Tube). The characteristics of two lamps are shown in the following tables.

$$T_a = 25 \pm 2^\circ\text{C}$$

Item	Symbol	Min.	Typ.	Max.	Unit	Note
Lamp Current	IL	3.0	8.0	9.0	mArms	(1)
Lamp Voltage	VL	-	560	-	Vrms	
Lamp Frequency	fL	40	-	60	kHz	(2)
Operating Life Time	Hr	50,000	-	-	Hour	(3)
Startup Voltage	Vs	-	-	25 :1,450	Vrms	(4)
				0 :1,680		

Note) The wave form of the inverter output voltage must be area symmetric and the design of the inverter must have specifications for the modularized lamp.

The performance of the back-light, for example life time or brightness, is much influenced by the characteristics of the DC-AC inverter for the lamp. So all the parameters of an inverter should be carefully designed so as not to produce too much leakage current from high-voltage output of the inverter. When you design or order the inverter, please make sure that a poor lighting caused by the mismatch of the back-light and the inverter (poor lighting, flicker, etc.) never occur. When you confirm it, the module should be operated in the same condition as it is installed in your instrument.

Note (1) Lamp current is measured with current meter for high frequency as shown below.

Refer to the block diagram of the back-light unit in the next page for more information. Specified values are for a single lamp.

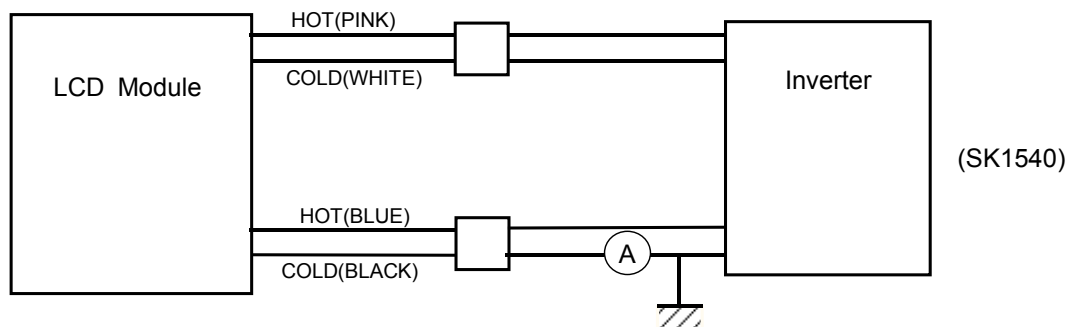

- (2) Lamp frequency which may produce interference with horizontal synchronous frequency may cause line flow on the display. Therefore lamp frequency should be detached from the horizontal synchronous frequency and its harmonics as far as possible in order to avoid interference.
- (3) Life time (Hr) of a lamp is defined as the time in which it continues to operate under the condition of $T_a = 25 \pm 2^\circ\text{C}$ and $I_L = 8.0\text{mArms}$ for a lamp until the brightness becomes 50% or lower than its original value. Operating condition is lamp unit itself, not module assembly at operating current 8.0mA.
- (4) If an inverter has shutdown function, it should keep its output for over 1 second even if the lamp connector is open. Otherwise the lamps may not be turned on.
- (5) Because the inverter uses high voltage, please disconnect it from the power before assembling or disassembling.

4. Block Diagram

4.1 TFT LCD MODULE

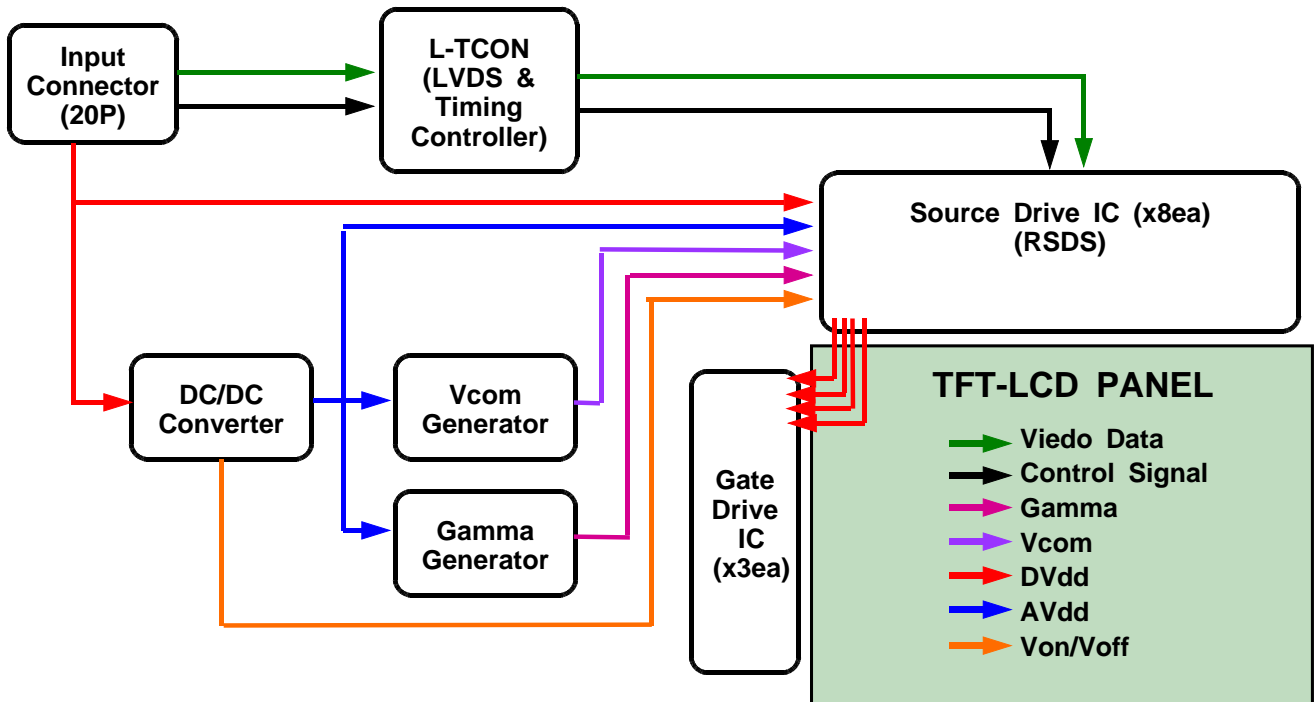

4.2 BACK-LIGHT UNIT

Connector : JST BHR-03VS-1(Module-side) or equivalent

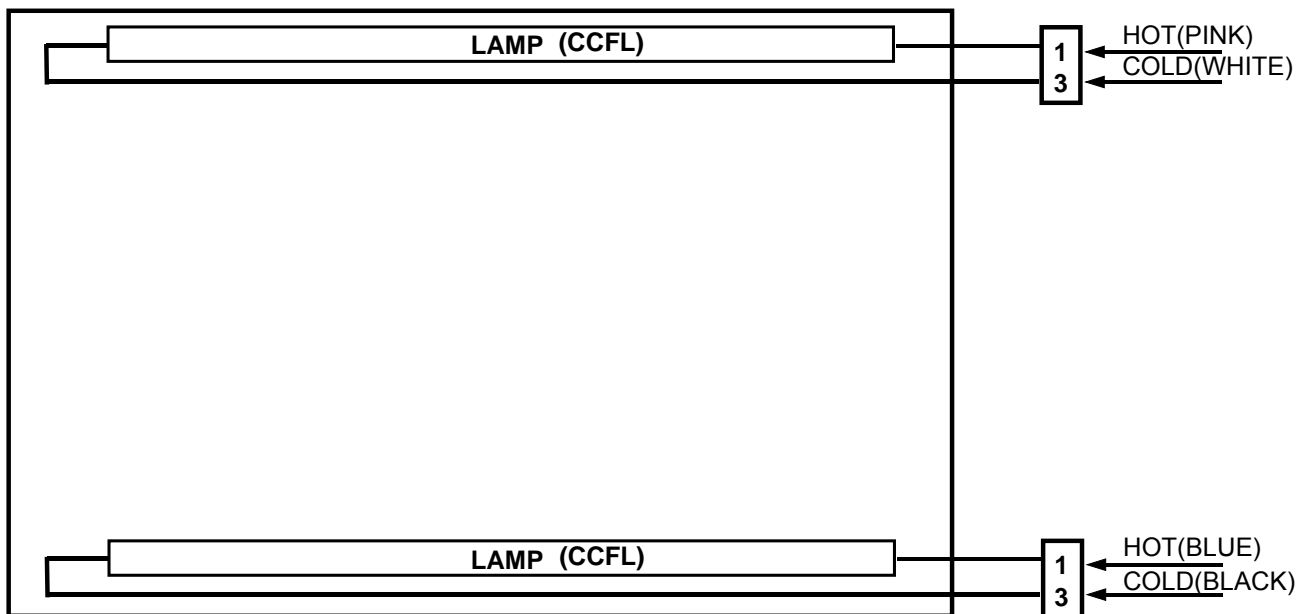

5. Input Terminal Pin Assignment

Approval

5.1. Input Signal & Power (Connector : Hirose DF14H-20P-1.25H or equivalent)

Pin No.	Symbol	Function	Remark
1	VDD	Power Supply 3.3V	
2	VDD	Power Supply 3.3V	
3	GND	Ground	
4	GND	Ground	
5	RX0-	Receiver Signal 0 (-)	
6	RX0+	Receiver Signal 0 (+)	
7	GND	Ground	
8	RX1-	Receiver Signal 1 (-)	
9	RX1+	Receiver Signal 1 (+)	
10	GND	Ground	
11	RX2-	Receiver Signal 2 (-)	
12	RX2+	Receiver Signal 2 (+)	
13	GND	Ground	
14	RXCLK-	Receiver Clock Signal(-)	
15	RXCLK+	Receiver Clock Signal(+)	
16	GND	Ground	
17	RX3-	Receiver Signal 3 (-)	
18	RX3+	Receiver Signal 3 (+)	
19	GND	Ground	
20	N.C	Reserved	

5.2 LVDS Interface

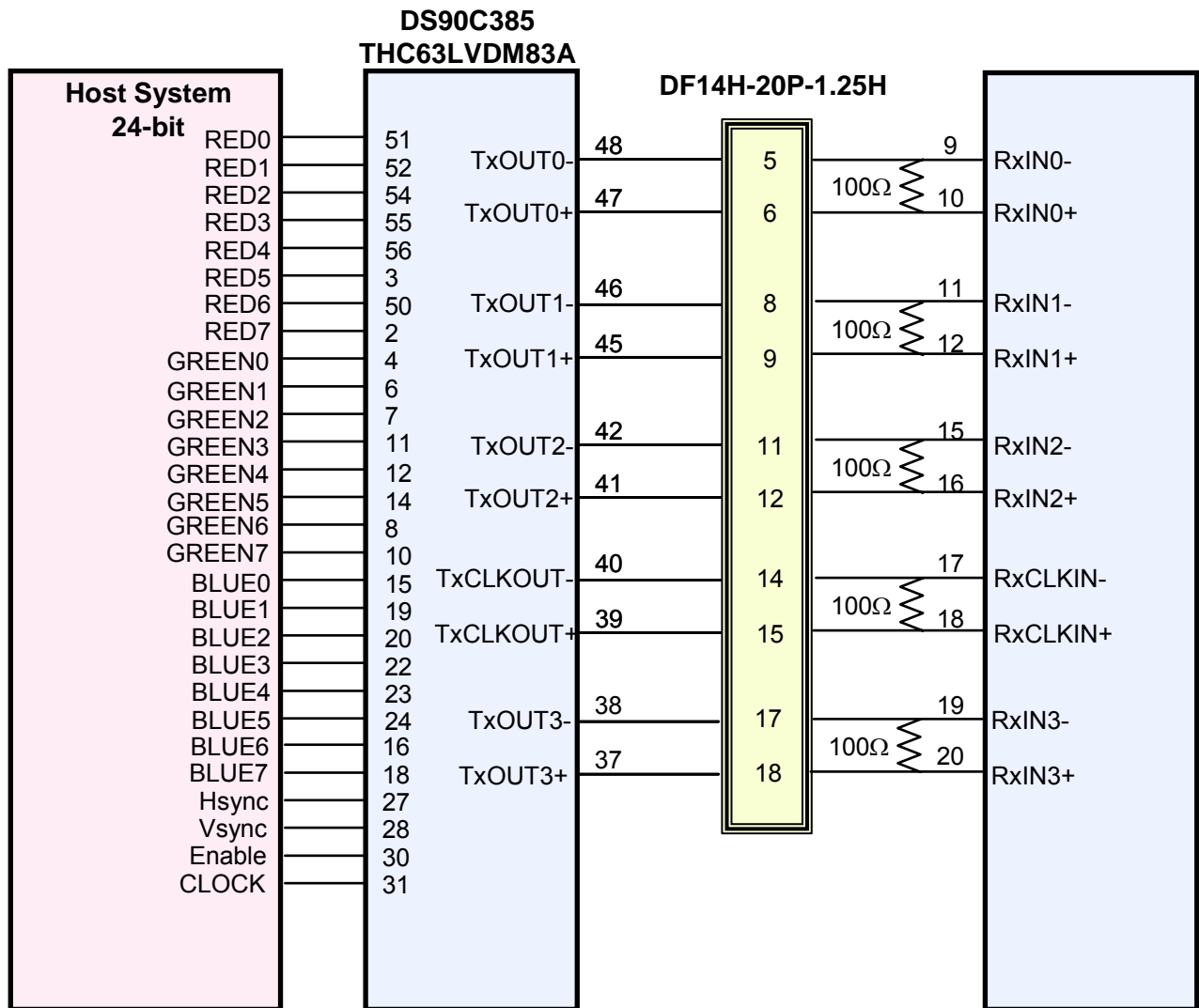

Note : The LCD Module uses a 100ohm resistor between positive and negative lines of each receiver input.

5.3 Back-Light Unit

Pin No.	Input [ch1]	Color	Function
1	Hot1	Pink(U), Blue(D)	High Voltage
2	NC	-	No connection
3	Cold1	White(U), Black(D)	Ground
Connector Part No.	JST BHR-03VS-1 (Module side socket) or equivalent		

5.4 Pixel Format

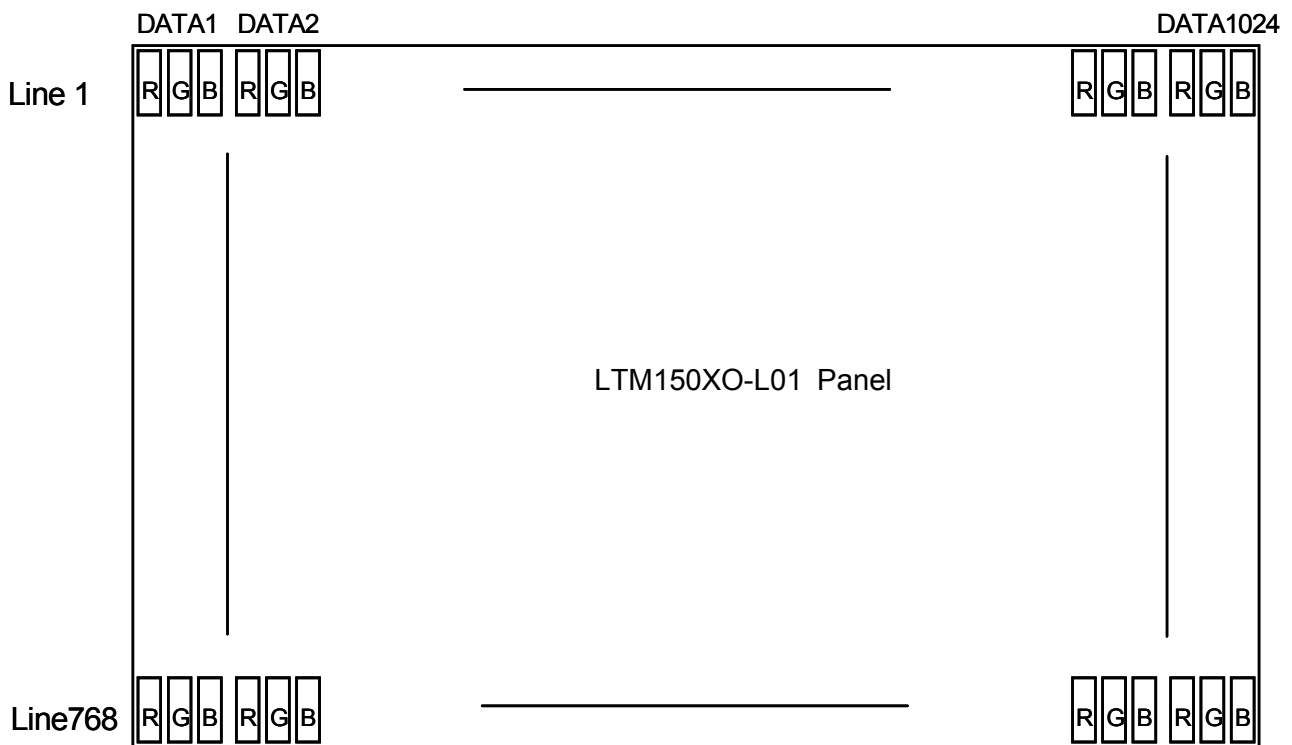

5.5 Input Signals, Basic Display Colors and Gray Scale of Each Color

COLOR	DISPLAY (8bit)	DATA SIGNAL																					GRAY SCALE LEVEL			
		RED							GREEN							BLUE										
		R0	R1	R2	R3	R4	R5	R6	R7	G0	G1	G2	G3	G4	G5	G6	G7	B0	B1	B2	B3	B4		B5	B6	B7
BASIC COLOR	BLACK	0	0	0	0	0	0	0	0	0	0	0	0	0	0	0	0	0	0	0	0	0	0	0	0	-
	BLUE	0	0	0	0	0	0	0	0	0	0	0	0	0	0	0	0	1	1	1	1	1	1	1	1	-
	GREEN	0	0	0	0	0	0	0	0	1	1	1	1	1	1	1	1	0	0	0	0	0	0	0	0	-
	CYAN	0	0	0	0	0	0	0	0	1	1	1	1	1	1	1	1	1	1	1	1	1	1	1	1	-
	RED	1	1	1	1	1	1	1	1	0	0	0	0	0	0	0	0	0	0	0	0	0	0	0	0	-
	MAGENTA	1	1	1	1	1	1	1	1	0	0	0	0	0	0	0	0	1	1	1	1	1	1	1	1	-
	YELLOW	1	1	1	1	1	1	1	1	1	1	1	1	1	1	1	1	0	0	0	0	0	0	0	0	-
	WHITE	1	1	1	1	1	1	1	1	1	1	1	1	1	1	1	1	1	1	1	1	1	1	1	1	-
GRAY SCALE OF RED	BLACK	0	0	0	0	0	0	0	0	0	0	0	0	0	0	0	0	0	0	0	0	0	0	0	R0	
	DARK	1	0	0	0	0	0	0	0	0	0	0	0	0	0	0	0	0	0	0	0	0	0	0	R1	
		0	1	0	0	0	0	0	0	0	0	0	0	0	0	0	0	0	0	0	0	0	0	0	R2	
		:	:	:	:	:	:	:	:	:	:	:	:	:	:	:	:	:	:	:	:	:	:	:	:	R3~ R252
	LIGHT	1	0	1	1	1	1	1	1	0	0	0	0	0	0	0	0	0	0	0	0	0	0	0	R252	
		0	1	1	1	1	1	1	1	0	0	0	0	0	0	0	0	0	0	0	0	0	0	0	R252	
		1	1	1	1	1	1	1	1	0	0	0	0	0	0	0	0	0	0	0	0	0	0	0	R252	
RED	1	1	1	1	1	1	1	1	0	0	0	0	0	0	0	0	0	0	0	0	0	0	0	R252		
GRAY SCALE OF GREEN	BLACK	0	0	0	0	0	0	0	0	0	0	0	0	0	0	0	0	0	0	0	0	0	0	0	G0	
	DARK	0	0	0	0	0	0	0	0	1	0	0	0	0	0	0	0	0	0	0	0	0	0	0	G1	
		0	0	0	0	0	0	0	0	0	1	0	0	0	0	0	0	0	0	0	0	0	0	0	G2	
		:	:	:	:	:	:	:	:	:	:	:	:	:	:	:	:	:	:	:	:	:	:	:	:	G3~ G252
	LIGHT	0	0	0	0	0	0	0	0	1	0	1	1	1	1	1	1	0	0	0	0	0	0	0	G252	
		0	0	0	0	0	0	0	0	0	1	1	1	1	1	1	1	0	0	0	0	0	0	0	G252	
		0	0	0	0	0	0	0	0	1	1	1	1	1	1	1	1	0	0	0	0	0	0	0	G252	
GREEN	0	0	0	0	0	0	0	0	1	1	1	1	1	1	1	1	0	0	0	0	0	0	0	G252		
GRAY SCALE OF BLUE	BLACK	0	0	0	0	0	0	0	0	0	0	0	0	0	0	0	0	0	0	0	0	0	0	0	B0	
	DARK	0	0	0	0	0	0	0	0	0	0	0	0	0	0	0	0	1	0	0	0	0	0	0	B1	
		0	0	0	0	0	0	0	0	0	0	0	0	0	0	0	0	0	1	0	0	0	0	0	B2	
		:	:	:	:	:	:	:	:	:	:	:	:	:	:	:	:	:	:	:	:	:	:	:	:	B3~ B252
	LIGHT	0	0	0	0	0	0	0	0	0	0	0	0	0	0	0	0	1	0	1	1	1	1	1	B252	
		0	0	0	0	0	0	0	0	0	0	0	0	0	0	0	0	0	1	1	1	1	1	1	B252	
		0	0	0	0	0	0	0	0	0	0	0	0	0	0	0	0	1	1	1	1	1	1	1	B252	
BLUE	0	0	0	0	0	0	0	0	0	0	0	0	0	0	0	0	1	1	1	1	1	1	1	B252		

Note) Definition of Gray

Rn : Red Gray, Gn : Green Gray, Bn : Blue Gray (n = Gray level)

Input Signal : 0 = Low level voltage, 1 = High level voltage

6. Interface Timing

6.1 Timing Parameters (DE only mode)

SIGNAL	ITEM	SYMBOL	MIN.	TYP.	MAX.	UNIT
Clock	Frequency	1/Tc	64	65	80	MHz
	High Time	TCH	2	-	-	nsec
	Low Time	TCL	2	-	-	nsec
Data	Setup Time	TDS	4	-	-	nsec
	Hold Time	TDH	4	-	-	nsec
Data Enable	Setup Time	TES	2	-	-	nsec
Frame Frequency	Cycle	Tv	-	16.7	13.3	msec
			772	806	870	lines
Vertical Active Display Term	Display Period	TVD	768	768	768	lines
One Line Scanning Time	Cycle	TH	1244	1344	1494	clocks
Horizontal Active Display Term	Display Period	THD	1024	1024	1024	clocks

Note (1) Test Point : TTL control signal and CLK at LVDS Tx input terminal in system

(2) Internal Vcc = 3.3V

6.2 Timing diagrams of interface signal (DE only mode)

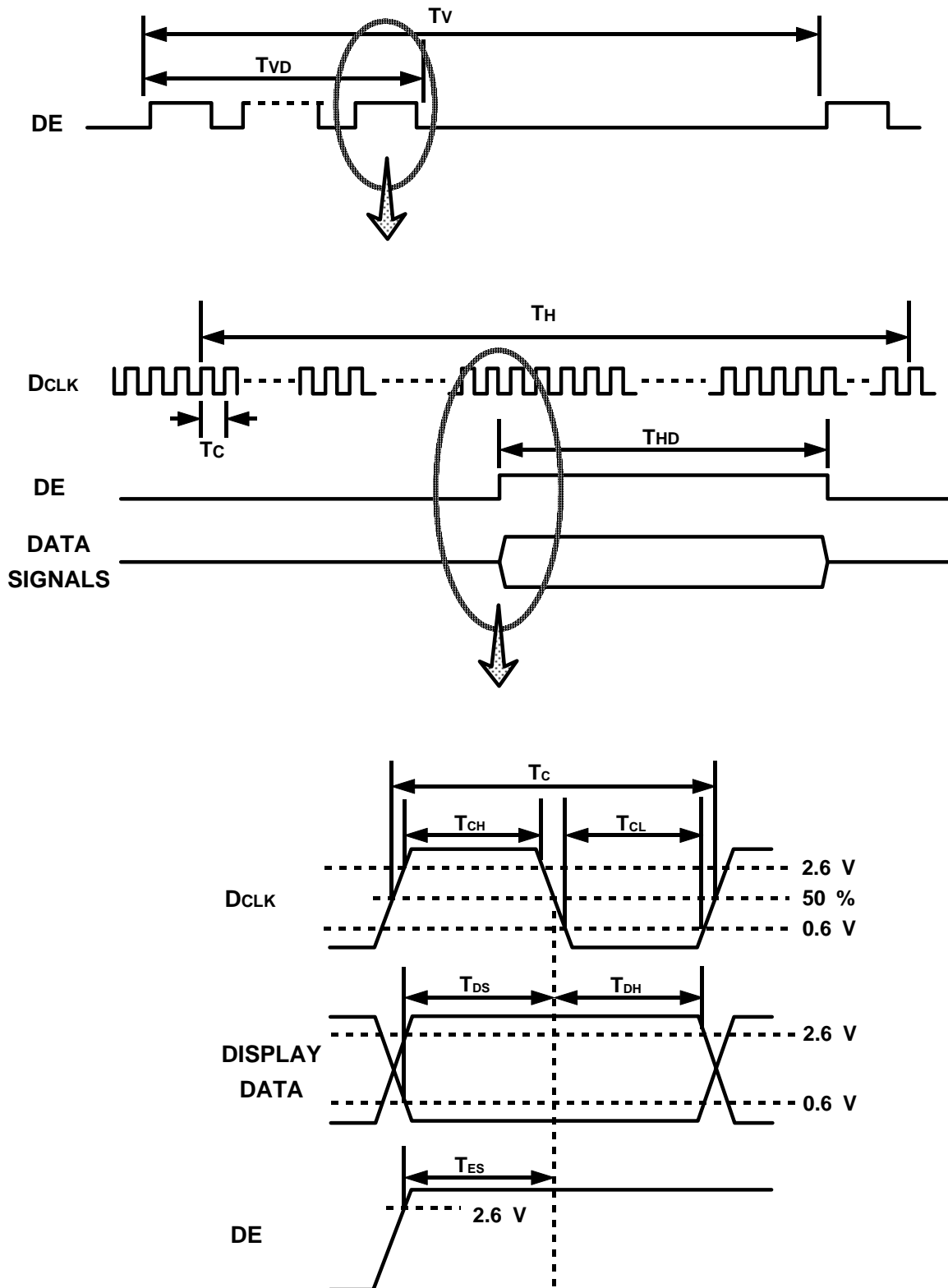

6.3 Power ON/OFF Sequence

To prevent a latch-up or DC operation of the LCD module, the power on/off sequence should be as the diagram below.

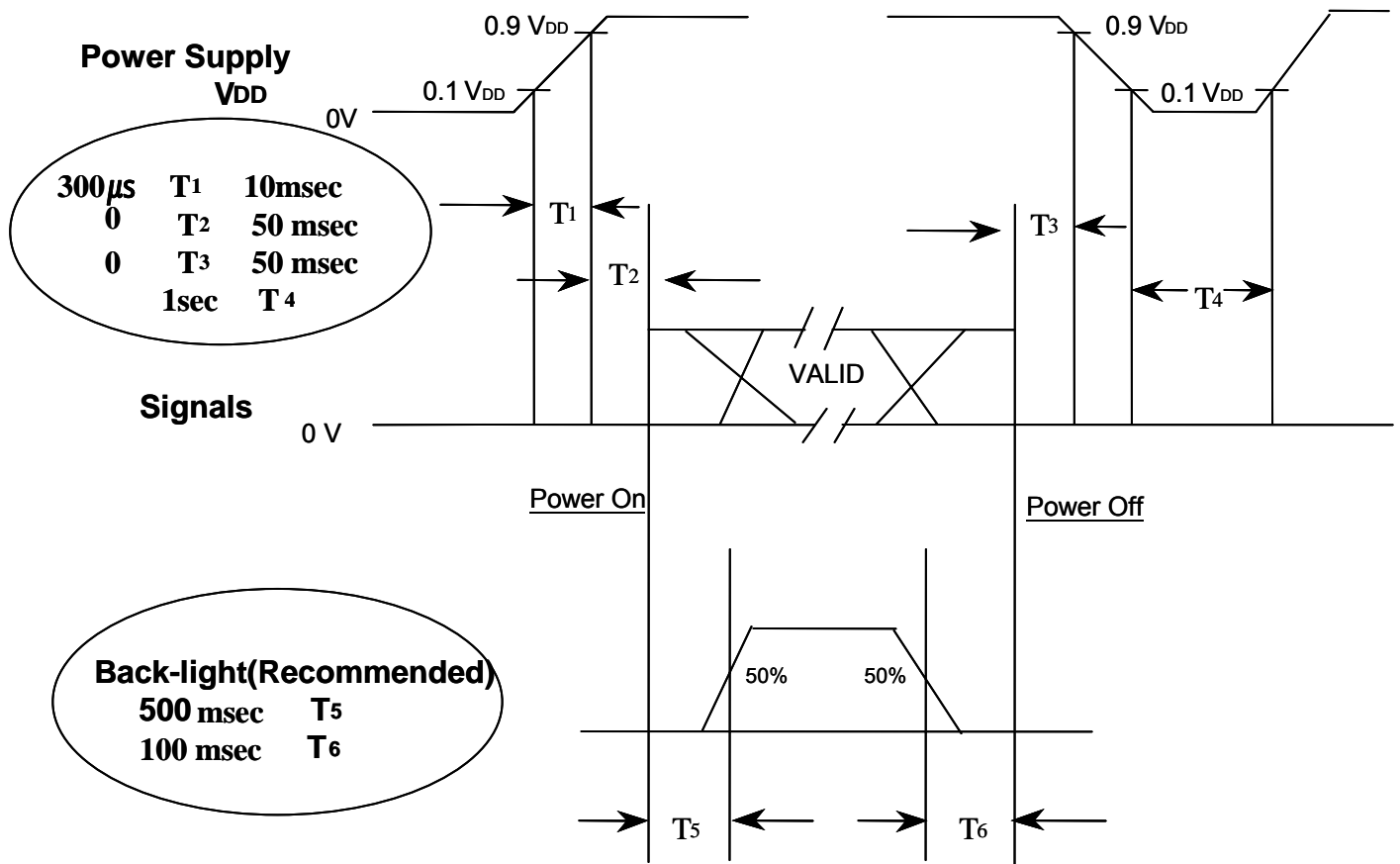

Power ON/OFF Sequence

- Note. (1) The supply voltage of the external system for the module input should be the same as the definition of V_{DD}.
- (2) Apply the lamp voltage within the LCD operation range. When the back-light turns on before the LCD operation or the LCD turns off before the back-light turns off, the display may momentarily show abnormal screen.
- (3) In case of V_{DD} = off level, please keep the level of input signals low or keep a high impedance.
- (4) T₄ should be measured after the module has been fully discharged between power off and on period.
- (5) Interface signal should not be kept at high impedance when the power is on.

7. Outline Dimension

[Refer to the next page]

Approval

NO	PART NAME	CODE NO	SPECIFICATION	QTY	WEIGHT TYPICAL	WEIGHT MINIMUM	UNFOLDED DIM. OF MATERIAL	REMARK

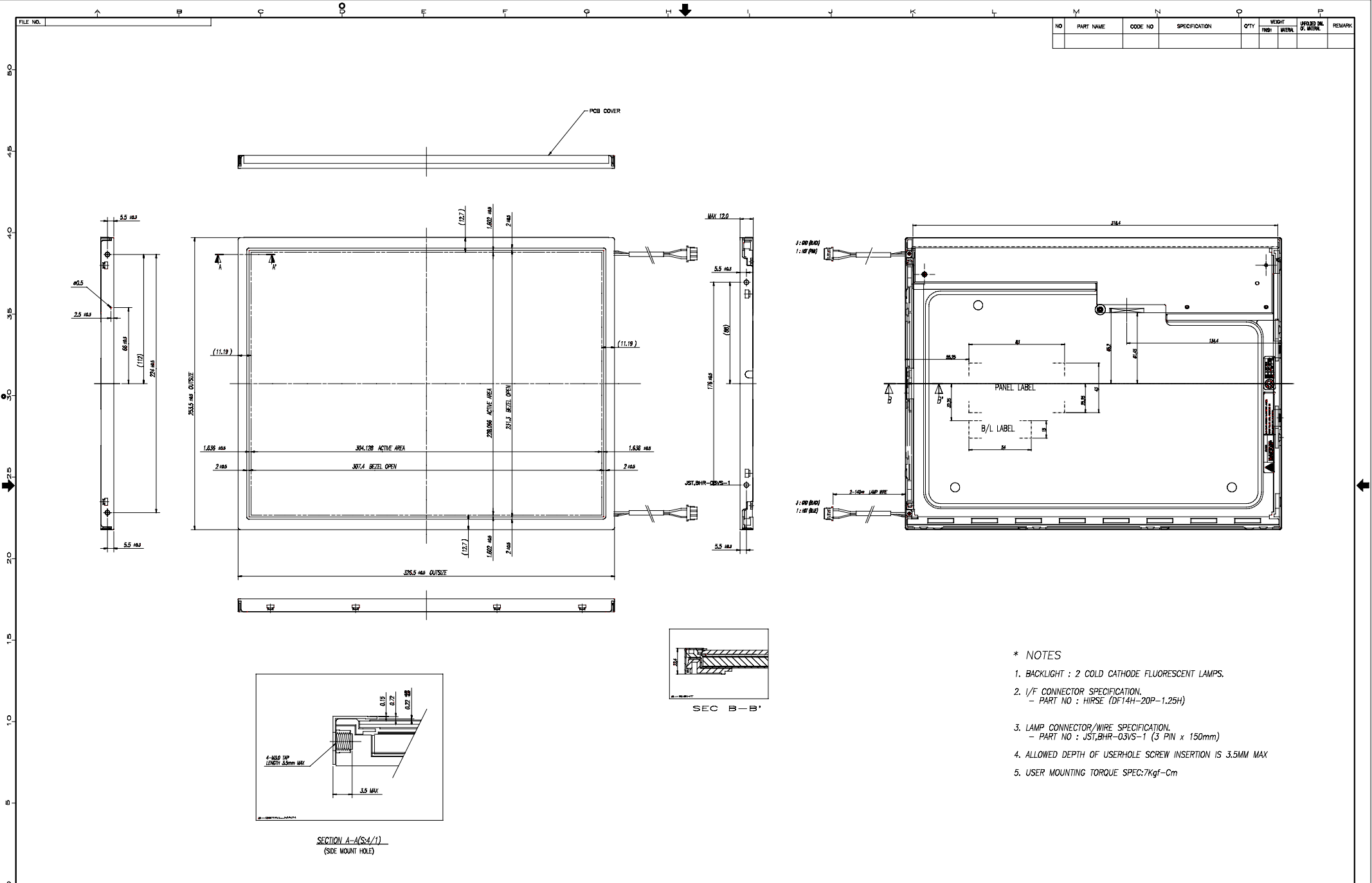

- * NOTES
- BACKLIGHT : 2 COLD CATHODE FLUORESCENT LAMPS.
 - I/F CONNECTOR SPECIFICATION.
- PART NO : HIRSE (DF14H-20P-1.25H)
 - LAMP CONNECTOR/WIRE SPECIFICATION.
- PART NO : JST,BHR-03VS-1 (3 PIN x 150mm)
 - ALLOWED DEPTH OF USERHOLE SCREW INSERTION IS 3.5MM MAX
 - USER MOUNTING TORQUE SPEC:7Kgf-Cm

REV	GENERAL TOLERANCE				REV DATE	DESCRIPTION OF REVISION			REASON	CHK'D BY
	STEP	LEVEL 1	LEVEL 2	LEVEL 3		UNIT	DRAWN BY	DES'G'D BY		
0 < X ≤ 4	±0.05	±0.1	±0.2	mm						
4 < X ≤ 18	±0.08	±0.15	±0.3	SCALE	N/A					
18 < X ≤ 64	±0.12	±0.25	±0.5	TOLERANCE						
64 < X ≤ 256	±0.25	±0.4	±0.8							

SAMSUNG ELECTRONICS				SPEC. NO.	
MODEL NAME	LTM150XO	PART/SHEET NAME	OUTLINE DIM.	SHEET	1/11
REASON		CODE NO.		VER.	00

8. Reliability Test

Approval

Test Items	Conditions	Time/Cycle	Sample	
HTOL*	50°C, Bias	500 hrs	12	
LTOL*	0°C, Bias	500 hrs	5	
THB**	40°C / 95%, Bias	500 hrs	5	
HTS***	70°C, No Bias	500 hrs	5	
LTS***	-30°C, No Bias	500 hrs	5	
Thermal Cycle	-20°C/30min ~ +60°C/30min, No bias	200 cycle	5	
Box Drop	1 angle, 3 edge, 6 side, 66 cm		5	
Shock (Non-operating)	50G, 11msec Sine wave , ± x/y/z axis	1 time/axis	3	
Vibration (Non-operating)	1.5G, 10~300 Hz x/y/z axis, sweep rate : 10 min	30min/axis	3	
ESD	Operating	contact : 150pF, 330ohm, 100point	± 8kV	3
		Air(non-contact) : 150pF, 330ohm, 100point	± 15kV	3
	Non-operating	CDM : 150pF, 330ohm, 9point, 3 times/point	± 10kV	3

[Result Evaluation Criteria]

Under the display quality test conditions with normal operation state, these should be no change which may affect practical display functions.

* HTOL/ LTOL : High/Low Temperature Operating Life,

** THB : Temperature Humidity Bias

*** HTS/LTS : High/Low Temperature Storage

9. PACKING

Approval

9.1 CARTON (Internal Package)

(1) Packing Form

Corrugated fiberboard box and corrugated cardboard as shock absorber

(2) Packing Method

a) Without Inverter

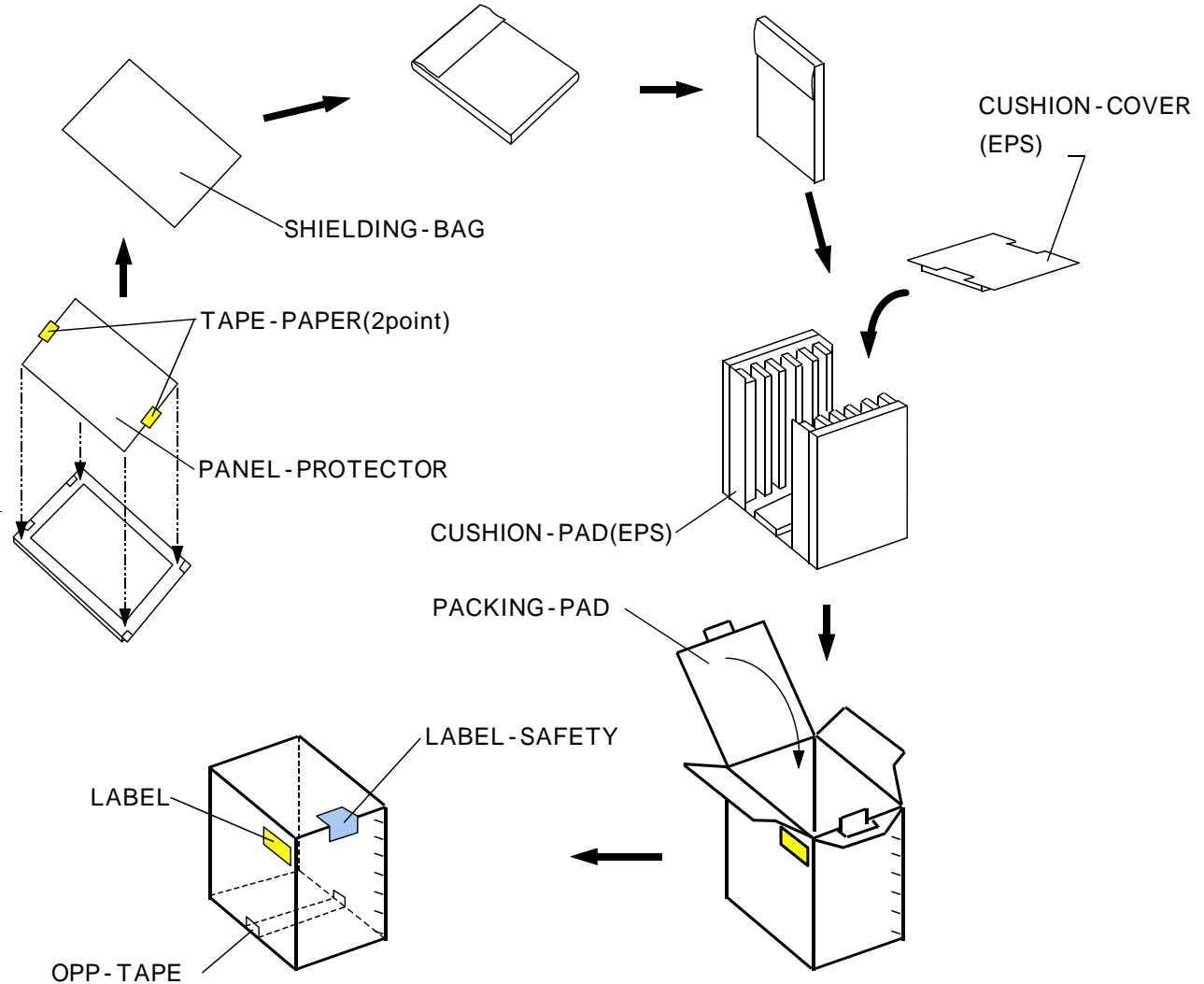

- NOTE) 1) TOTAL : Approx. 11.0kg
2) Acceptance number of piling : 10sets
3) Carton size :450(W) X 348(D) X 440(H)
4) MAX accumulation quantity : 5 cartons

(3) Packing Material

No	Part name	Quantity
1	Static electric protective sack	10
2	Packing case(Inner box) included shock absorber	1 set
3	Pictorial marking	2 pics
4	Carton	1 set

10. MARKING & OTHERS

A nameplate bearing followed by is affixed to a shipped product at the specified location on each product.

- (1) Parts number : LTM150XO-L01
- (2) Revision code : Two letters
- (3) Customer code : One letter

X XX

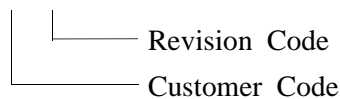

- (4) Lot number : 5 X 4 H 00602K

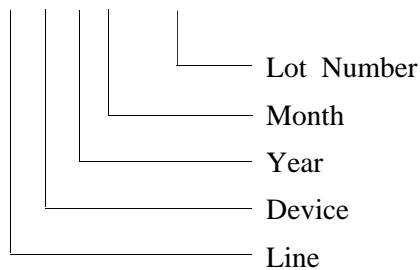

(5) Nameplate Indication

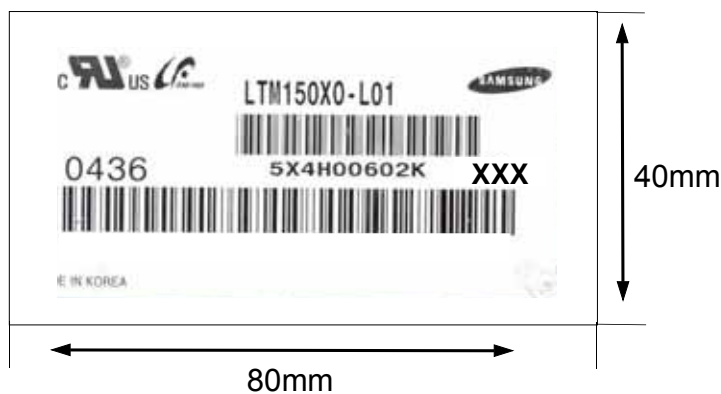

Week Code : 0436

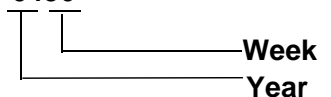

(6) Packing box attach

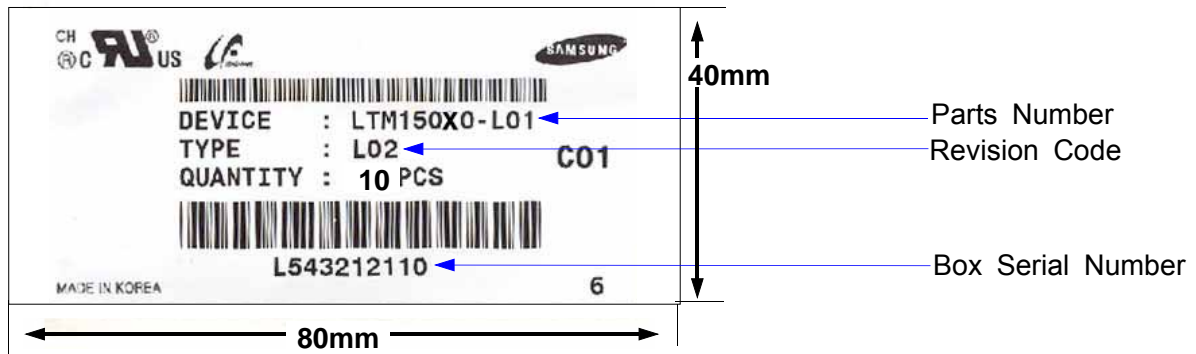

(7) Others

1. After service part

Part Name	Description
ASS'Y-LAMP(U)	LTM150XO, D2.4, L317, 3PIN
ASS'Y-LAMP(L)	LTM150XO, D2.4, L317, 3PIN

11. Inspection Criteria

Approval

When products are shipped, incoming inspection should be carried out with a sampling inspection based on MIL-STD-105E level II by AQL 1.0%.

CHANGE CONTROL

Design of the product may be changed regarding the specifications, appearance, parts used, circuits, etc. for product improvement.

If a design change is judged to affect the specifications of this product, supplier should inform customer of the change in advance.

QUALITY CONTROL

In the event of a product failure under normal operating conditions, a product trouble or a functional disorder that can be deemed to be the responsibility of supplier, supplier should repair the fault or replace the product free of charge within one year from the product delivery date. However, supplier does not take responsibility for the product quality in the case of modifications not specified by supplier.

MAINTENANCE

The specifications of the functions of maintenance parts may be partially changed within the range which provides equivalent or better quality.

In principle, maintenance parts should be product units.

When stopping manufacturing this product, supplier should notify customer in advance.

HANDLING OF DOUBTFUL POINTS

Any doubt not stipulated in this specification is to be resolved by mutual agreement between customer and supplier, and supplier should make efforts for improvement in good faith.

12.1 Handling

- (a) When the module is assembled, it should be attached to the system firmly using all mounting holes. Be careful not to twist and bend the module.
- (b) Because the inverter use high voltage, it should be disconnected from power before it is assembled or disassembled.
- (c) Refrain from strong mechanical shock and / or any force to the module. In addition to damage, this may cause improper operation or damage to the module and CCFT back-light.
- (d) Note that polarizers are very fragile and could be damage deasily. Do not press or scratch the surface harder than a HB pencil lead.
- (e) Wipe off water droplets or oil immediately. If you leave the droplets for a long time, staining or discoloration may occur.
- (f) If the surface of the polarizer is dirty, clean it using some absorbent cotton or soft cloth.
- (g) Desirable cleaners are water, IPA(Isopropyl Alcohol) or Hexane. Do not use Ketone type materials(ex. Acetone), Ethyl alcohol, Toluene, Ethyl acid or Methyl chloride. It might permanent damage to the polarizer due to chemical reaction.
- (h) If the liquid crystal material leaks from the panel, it should be kept away from the eyes or mouth . In case of contact with hands, legs or clothes, it must be washed away with soap thoroughly.
- (i) Protect the module from static, or the CMOS Gate Array IC would be damaged.
- (j) Use finger-stalls with soft gloves in order to keep display clean during the incoming inspection and assembly process.
- (k) Do not disassemble the module.
- (l) Do not pull or fold the lamp wire.
- (m) Do not adjust the variable resistor located on the module.
- (n) Protection film for polarizer on the module should be slowly peeled off just before use so that the electrostatic charge can be minimized.
- (o) Pins of I/F connector should not be touched directly with bare hands.

12.2 Storage

- (a) Do not leave the module in high temperature, and high humidity for a long time. It is highly recommended to store the module with temperature from 0 to 35 and relative humidity of less than 70%.
- (b) Do not store the TFT-LCD module in direct sunlight.
- (c) The module should be stored in a dark place. It is prohibited to apply sunlight or fluorescent light in storing.

12.3 Operation

- (a) Do not connect or disconnect the module in the "Power On" condition.
- (b) Power supply should always be turned on/off by the item 6.3 "Power on/off sequence"
- (c) Module has high frequency circuits. Sufficient suppression to the electromagnetic interference should be done by system manufacturers. Grounding and shielding methods may be important to minimize the interference.
- (d) The cable between the back-light connector and its inverter power supply should be connected directly with a minimized length. A longer cable between the back-light and the inverter may cause lower luminance of lamp(CCFT) and may require higher startup voltage(Vs).

12.4 Others

- (a) Ultra-violet ray filter is necessary for outdoor operation.
- (b) Avoid condensation of water. It may result in improper operation or disconnection of electrode.
- (c) Do not exceed the absolute maximum rating value. (supply voltage variation, input voltage variation, variation in part contents and environmental temperature, and so on)
Otherwise the module may be damaged.
- (d) If the module keeps displaying the same pattern for a long period of time, the image may be "sticked" to the screen.
To avoid image sticking, it is recommended to use a screen saver.
- (e) This module has its circuitry PCB's on the rear side and should be handled carefully in order not to be stressed.
- (f) Please contact SEC in advance when you display the same pattern for a long time.