



ELECTRONICS

Product Information

Customer :

DATE : Jan. 11, 2008

SAMSUNG TFT-LCD
MODEL : LTA400HA07

The Information Described in this Specification is Preliminary and can be changed without prior notice

NOTE :

Customer's Approval	
SIGNATURE	DATE

APPROVAED BY <i>Kyunghwan Ko</i>	DATE Jan. 11, 2008
PREPARED BY <i>Byungsun Park</i>	DATE Jan. 11, 2008

LCD Business

Samsung Electronics Co . , LTD.

Contents

Revision History	(3)
General Description	(4)
General Information	(4)
1. Absolute Maximum Ratings	(5)
2. Optical Characteristics	(6)
3. Electrical Characteristics	(9)
3.1 TFT LCD Module	
3.2 Back Light Unit	
3.3 Inverter Input & Specification	
4. Block Diagram	(12)
5. Input Terminal Pin Assignment	(13)
4.1 Input Signal & Power	
4.2 Inverter Input Pin Configuration	
4.3 Inverter Input Power Sequence	
4.4 LVDS Interface	
4.5 Input Signals, Basic Display Colors and Gray Scale of Each Color	
6. Interface Timing	(18)
5.1 Timing Parameters (DE only mode)	
5.2 Timing Diagrams of interface Signal (DE only mode)	
5.3 Power ON/OFF Sequence	
7. Outline Dimension	(21)
8. Packing	(23)
9. Marking & Others	(24)
10. General Precaution	(25)
10.1 Handling	
10.2 Storage	
10.3 Operation	
10.4 Operation Condition Guide	
10.5 Others	

*** Revision History**

Date	Rev. No	Page	Summary
Jan. 11 2008	000	all	First issued

General Description

Description

LTA400HA07 is a color active matrix liquid crystal display (LCD) that uses amorphous silicon TFT (Thin Film Transistor) as switching components. This model is composed of a TFT LCD panel, a driver circuit and a back light unit. The resolution of a 40.0" is 1920 x 1080 and this model can display up to 16.7 million colors with wide viewing angle of 89° or higher in all directions. This panel is intended to support applications to provide an excellent performance for Flat Panel Display such as Home-alone Multimedia TFT-LCD TV and High Definition TV

Features

- RoHS (Directive 2002/95/EC) compliance (Pb-free)
- High contrast ratio & aperture ratio with wide color gamut
- SPVA (Super Patterned Vertical Align) mode
- Wide viewing angle ($\pm 178^\circ$)
- High speed response & Natural Motion
- FHD resolution (16:9)
- Low Power consumption
- Direct Type 16 CCFLs (Cold Cathode Fluorescent Lamp)
- DE (Data Enable) mode
- LVDS (Low Voltage Differential Signaling) interface (2pixel/clock)

General Information

Items	Specification	Unit	Note
Module Size	952(H _{Typ}) x 551(V _{Typ})	mm	±1.0mm
	55.2(D _{MAX})		
Weight	10,000(Max.)	g	
Pixel Pitch	0.46125(H) x 0.46125(W)	mm	
Active Display Area	885.6(H) x 498.15(V)	mm	
Surface Treatment	Haze 14% , Hard-coating (3H)		
Display Colors	8bit – 16.7 M	colors	
Number of Pixels	1920 x 1080	pixel	
Pixel Arrangement	RGB vertical stripe		
Display Mode	Normally Black		
Luminance of White	500 (Typ.)	cd/m ²	

MODEL

LTA400HA07

Doc. No

06-000-G-080111

Page

4 / 27

1. Absolute Maximum Ratings

If the condition exceeds maximum ratings, it can cause malfunction or unrecoverable damage to the device.

Item	Symbol	Min.	Max.	Unit	Note	
Power Supply Voltage	V_{DD}	GND-1	13.2	V	(1)	
Storage temperature	T_{STG}	-20	60	°C	(2)	
Glass surface Temperature (operation)	Center	T_{OPR}	0	50	°C	(2)
	T. uniformity	ΔT	0	10	°C	
Shock (non - operating)	S_{NOP}	X,Y	-	40	G	(3)
		Z	-	30		
Vibration (non - operating)	V_{nop}	-	1.5	G	(4)	

Note (1) $T_a = 25 \pm 2$ °C

(2) Temperature and relative humidity range are shown in the figure below.

a. 90 % RH Max. ($T_a \leq 39$ °C)

b. Relative Humidity is 90% or less. ($T_a > 39$ °C)

c. No condensation

(3) 11ms, sine wave, one time for $\pm X$, $\pm Y$, $\pm Z$ axis

(4) 10-300 Hz, Sweep rate 10min, 30min for X,Y,Z axis

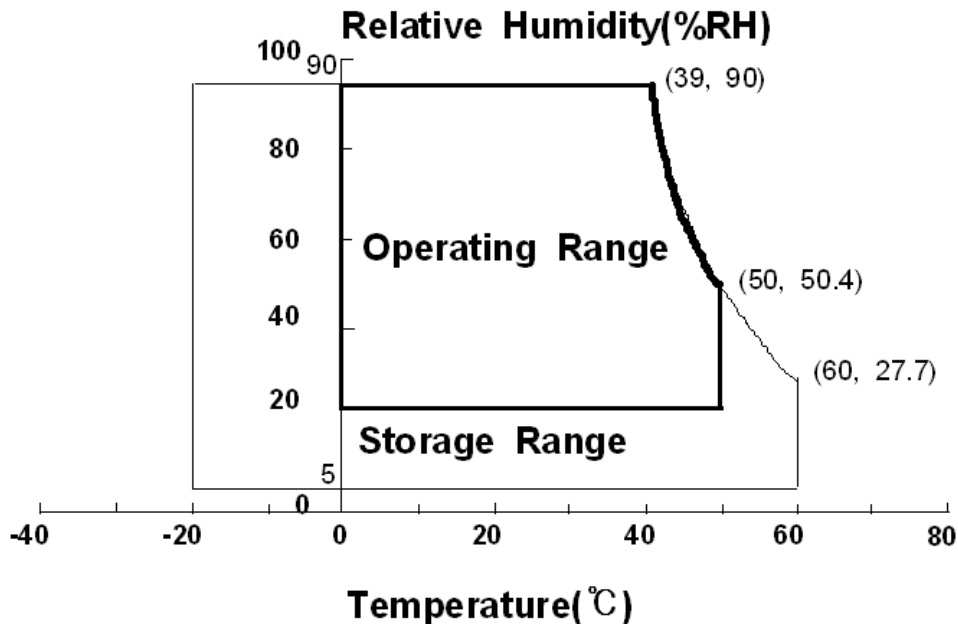

Fig. Temperature and Relative humidity range

2. Optical Characteristics

The optical characteristics should be measured in a dark room or equivalent.

Measuring equipment : TOPCON BM-7,SPECTRORADIOMETER SR-3, ELDIM EZ-Contrast

(Ta = 25 ± 2°C, VDD=12V, fv= 60Hz, Dimming Max. =3.3V , f_{DCLK}=148.5MHz)

Item		Symbol	Condition	Min.	Typ.	Max.	Unit	Note
Contrast Ratio (Center of screen)		C/R	Normal $\theta_{L,R}=0$ $\theta_{U,D}=0$ Viewing Angle	2,000	3000	-		(1) SR-3
Response Time	G-to-G	Tg		-	8	-	msec	(3) RD-80S
Luminance of White (Center of screen)		Y _L		400	500	-	cd/m ²	(4) SR-3
Color Chromaticity (CIE 1931)	Red	Rx		TYP. -0.03	TYP. +0.03	0.642		(5),(6) SR-3
		Ry	0.337					
	Green	Gx	0.280					
		Gy	0.605					
	Blue	Bx	0.147					
		By	0.060					
	White	Wx	0.280					
		Wy	0.290					
Color Gamut		-	-	72	-	%	(5) SR-3	
Color Temperature		-	-	10000	-	K	(5) SR-3	
Viewing Angle	Hor.	θ_L	C/R≥10	Degree	75	89	-	(6) EZ-Contrast
		θ_R			75	89	-	
	Ver.	θ_U			75	89	-	
		θ_D			75	89	-	
Brightness Uniformity of White (9 Points)		B _{uni}	-	-	25	%	(2) SR-3	

- Test Equipment Setup

The measurement should be executed in a stable, windless and dark room between 40min and 60min after lighting the back light at the given temperature for stabilization of the back light. This should be measured in the center of screen.

Dimming Max. =3.3V

Environment condition : Ta = 25 ± 2 °C

Photo detector	Field
SR-3	1°
BM-7	2°

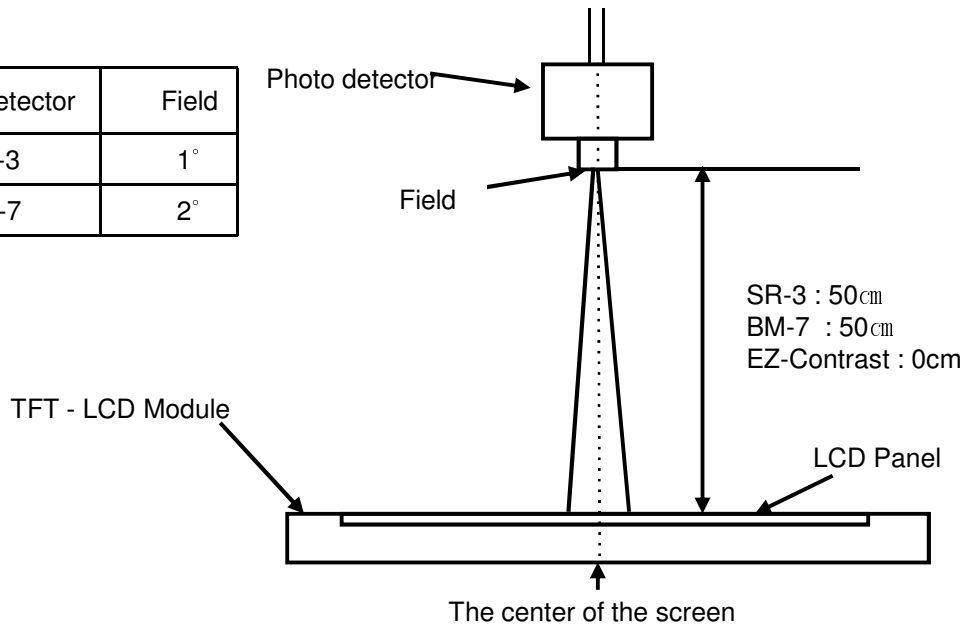

- Definition of test point

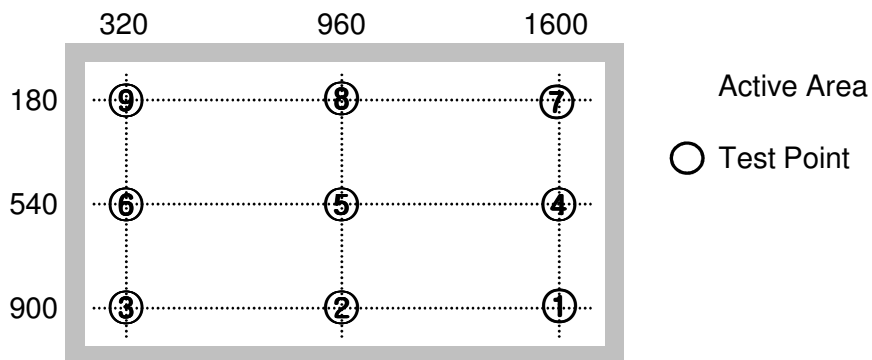

Note (1) Definition of Contrast Ratio (C/R)

: Ratio of gray max (Gmax) & gray min (Gmin) at the center point ⑤ of the panel

Gmax : Luminance with all pixels white

Gmin : Luminance with all pixels black

Note (2) Definition of 9 points brightness uniformity of White At Max dimming voltage

Bmax : Maximum brightness
 Bmin : Minimum brightness

Note (3) Definition of Response time : Sum of Tr, Tf

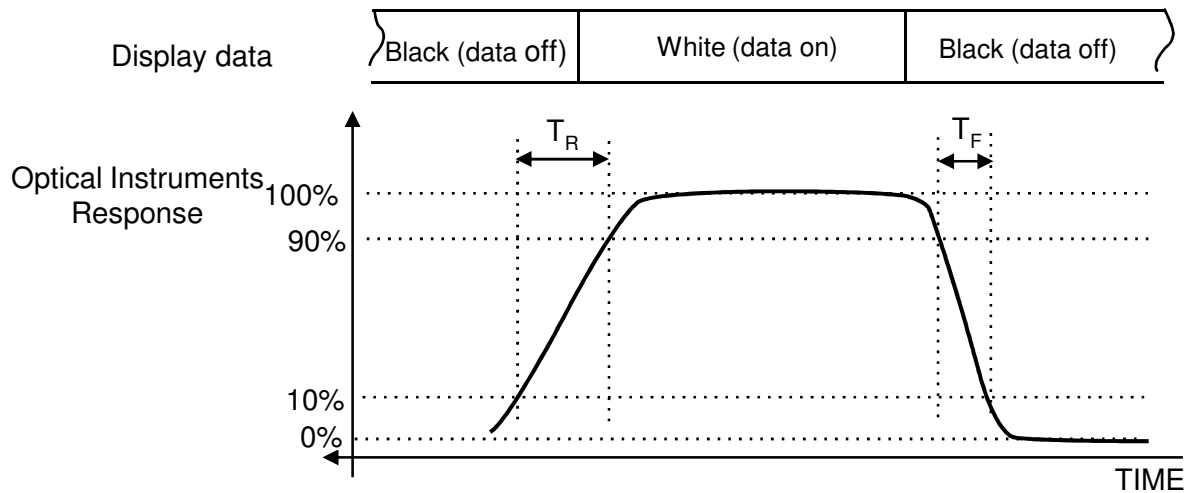

Note (4) Definition of Luminance of White : Luminance of white at center point ⑤

Note (5) Definition of Color Chromaticity (CIE 1931)
 Color coordinate of Red, Green, Blue & White at center point ⑤

Note (6) Definition of Viewing Angle
 : Viewing angle range ($C/R \geq 10$)

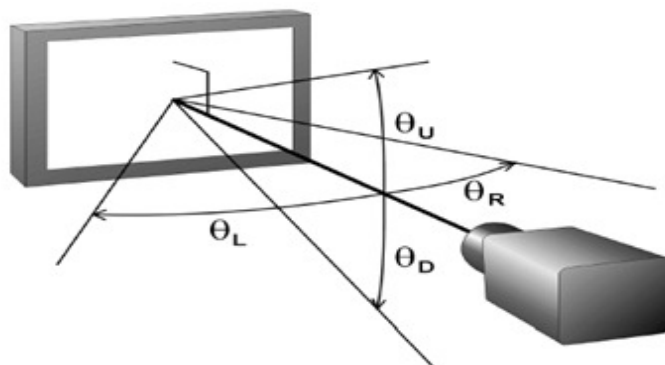

3. Electrical Characteristics

3.1 TFT LCD Module

The connector for display data & timing signal should be connected.

$T_a = 25^\circ\text{C} \pm 2^\circ\text{C}$

Item	Symbol	Min.	Typ.	Max.	Unit	Note
Voltage of Power Supply	V_{DD}	10.8	12	13.2	V	(1)
Current of Power Supply	(a) Black	-	550	750	mA	(2),(3)
	(b) White	-	1100	1400	mA	
	(c) N-pattern	-	1200	1500	mA	
Vsync Frequency	f_v	48	60	63	Hz	
Hsync Frequency	f_H	50	67.5	70	kHz	
Main Frequency	f_{DCLK}	130	148.5	153	MHz	
Rush Current	I_{RUSH}	-	-	4.5	A	(4)

Note (1) The ripple voltage should be controlled under 10% of V_{DD} .

(2) $f_v=60\text{Hz}$, $f_{DCLK} = 148.5\text{MHz}$, $V_{DD} = 12.0\text{V}$, DC Current.

(3) Power dissipation check pattern (LCD Module only)

a) Black Pattern b) White Pattern c) N-pattern

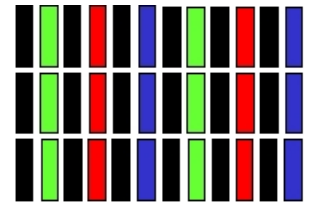
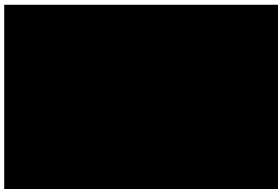

(4) Measurement Conditions

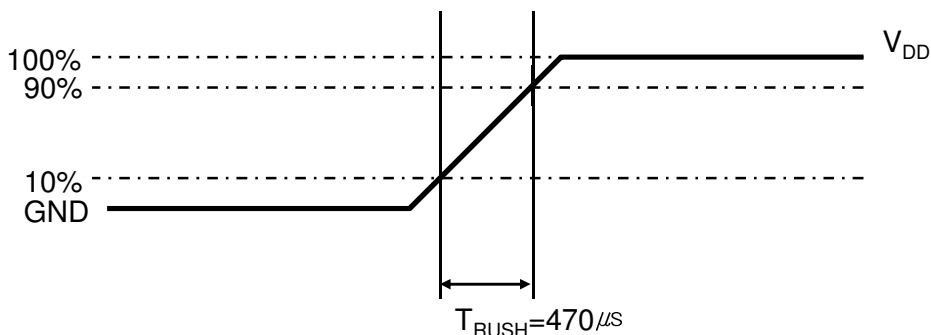

Rush Current I_{RUSH} can be measured when T_{RUSH} is $470\mu\text{s}$.

3.2 Back Light Unit

The back light unit contains 16 direct-lighting type CCFLs (Cold Cathode Fluorescent Lamp). The characteristics of lamps are shown in the following tables.

$T_a = 25 \pm 2^\circ\text{C}$

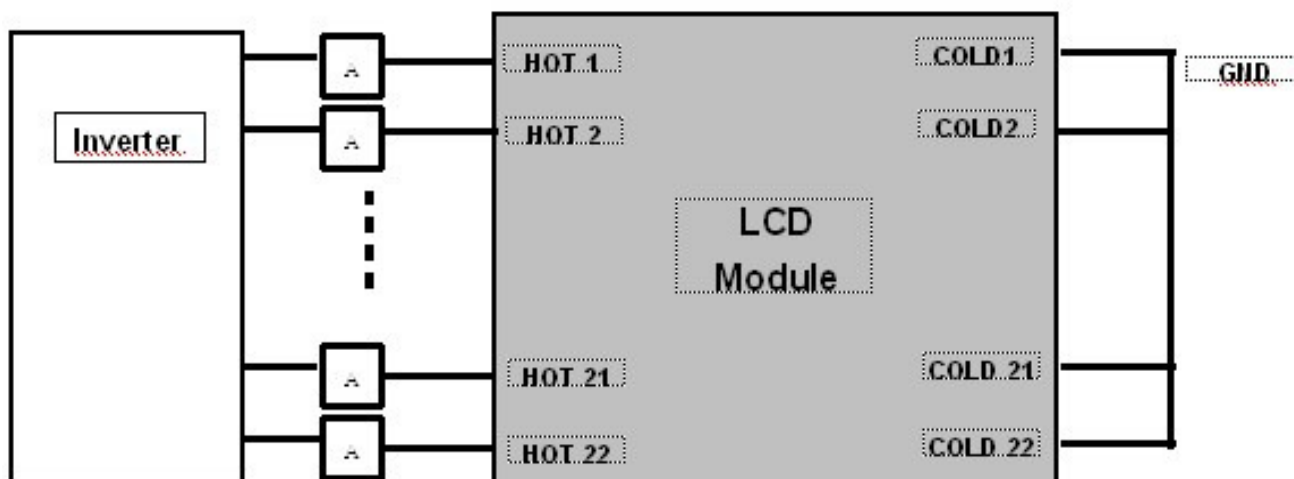

Item	Symbol	Min.	Typ.	Max.	Unit	Note
Operating Life Time	Hr	50,000	-	-	Hour	(1)

Note (1) Life time (Hr) of a lamp : It is defined as the time in which it continues to operate under the condition of $T_a = 25 \pm 2^\circ\text{C}$ for a lamp until the brightness becomes 50% or lower than it's original value.

3.3 Inverter Input Condition & Specification

Items	Symbol	Conditions	Specifications			Unit	Note
			Min.	Typ.	Max.		
Input Voltage	V _{in}	-	22.8	24	25.2	V	Ta=25±2 °C
Input Current	I _{RUSH}	V _{in} =24.0V V _{dim} =3.3V Ta=25 °C	-	-	10	A	(1)
Lamp Current	I _{O,MAX}	V _{dim} =3.3V	8.00	8.5	9.0	mArms	-
Backlight On/Off	ON	V _{in} =24.0 V	2.4	-	5.3	V	-
	OFF	V _{in} =24.0 V	0	-	0.8		
Dimming Control	V _{DIM}	Max. Lum PWM = 100%	-	3.3	-	V	-
		Min. Lum PWM = 20%	-	0	-		

Note) Power Consumption is measured when 500 [cd/m²] of luminance which is the typical luminance.
Lamp Current is measured at the point before Lamp.

(1) Max Value of the Power Consumption is measured during initial turn-on time* of the backlight

4. Block Diagram

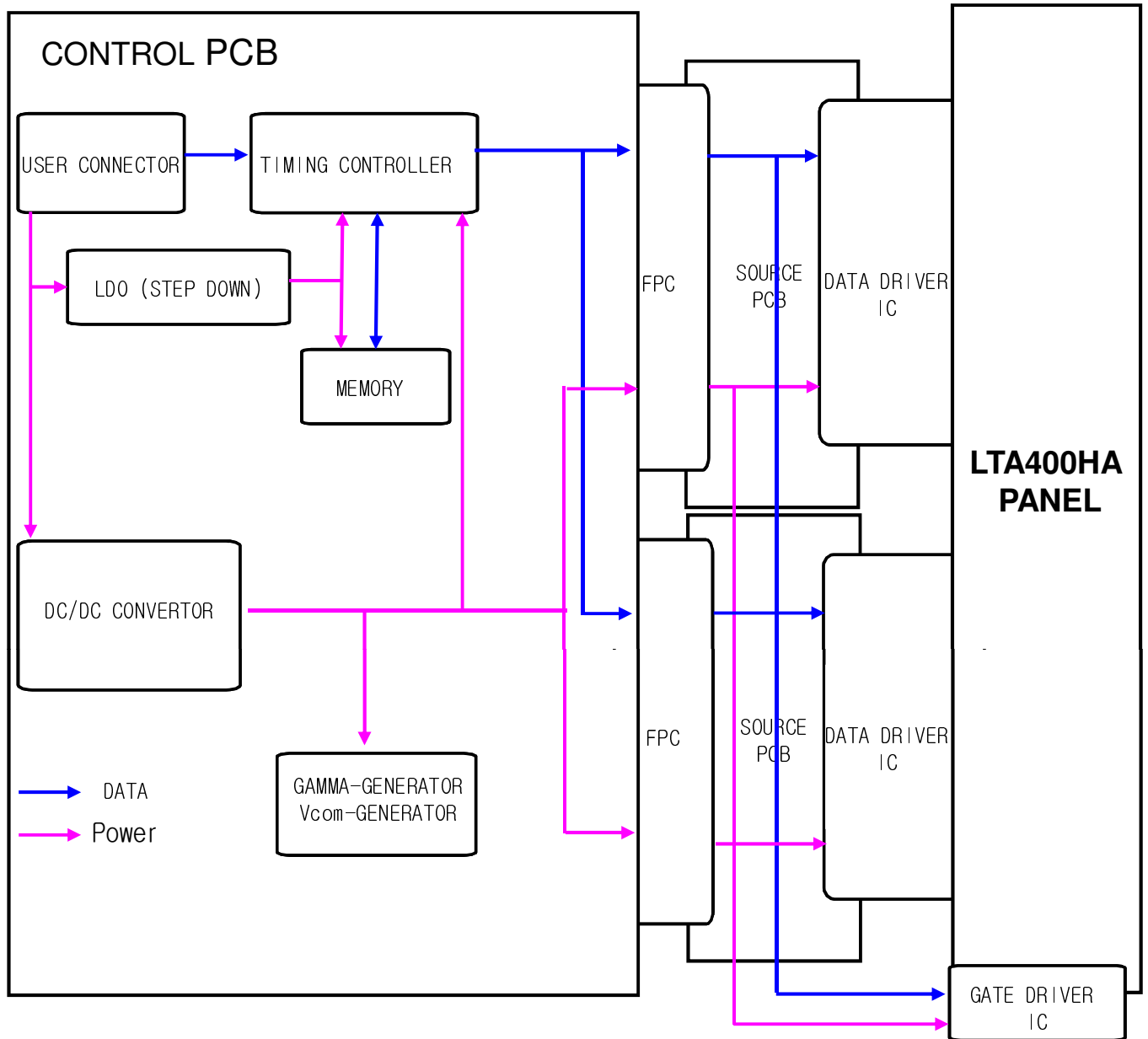

5. Input Terminal Pin Assignment

5.1. Input Signal & Power

Connector : FI-RE51S-HF (JAE)

Pin	Description		Pin	Description		
1	Vdd (12V)		26	Even LVDS Signal	RE[0]P	
2	Vdd (12V)		27		RE[1]N	
3	Vdd (12V)		28		RE[1]P	
4	Vdd (12V)		29		RE[2]N	
5	Vdd (12V)		30		RE[2]P	
6	GND		31		GND	
7	GND		32		RECLK-	
8	GND		33		RECLK+	
9	GND		34		GND	
10	Odd LVDS Signal	RO[0]N	35		RE[3]N	
11		RO[0]P	36		RE[3]P	
12		RO[1]N	37		No connection	
13		RO[1]P	38		No connection	
14		RO[2]N	39		GND	
15		RO[2]P	40		No connection	
16		GND	41		No connection	
17		ROCLK-	42	No connection		
18		ROCLK+	43	No connection		
19		GND	44	No connection		
20		RO[3]N	45	LVDS_SEL	NOTE2	
21		RO[3]P	46	No connection		
22		No connection	47	No connection		
23		No connection	48	No connection		
24	GND		49	No connection		
25	Even LVDS	RE[0]N	50	No connection		
			51	No connection		

(Note1) These PINS are only used for SAMSUNG internal using. DO NOT CONNECT.

(Note2) LVDS OPTION : If this PIN : HIGH (3.3 V) → Normal LVDS format
: LOW (GND) → JEIDA LVDS format (Default)

SEQUENCE : On = VDD(T1) ≥ LVDS Option ≥ Interface Signal(T2)

OFF = Interface Signal(T3) ≥ LVDS Option ≥ VDD

Note(3) Pin number starts from Left side

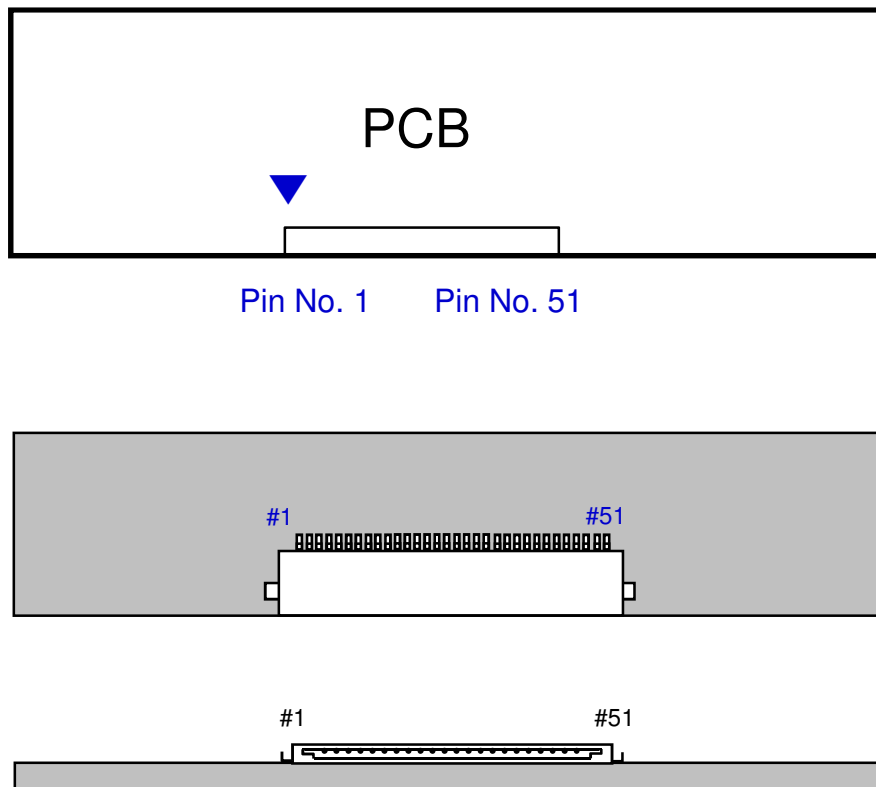

Fig. Connector diagram

- a. All GND pins should be connected together and also be connected to the LCD's metal chassis.
- b. All power input pins should be connected together.
- c. All NC pins should be separated from other signal or power.

5.2. Inverter Input Pin Configuration

Connector : S14B-PHA-SM-TB(LF) (JST)

Pin No.	Pin Configuration (MASTER / SLAVE)
1	24 V
2	24 V
3	24 V
4	24 V
5	24 V
6	GND
7	GND
8	GND
9	GND
10	GND
11	No Connection
12	Backlight On /Off [ON:2.4 - 5.25 V, OFF: 0 - 0.8 V]
13	Dimming Control [0V:Min, 3.3V:Max]
14	No Connection

5.3. Inverter Input Power Sequence

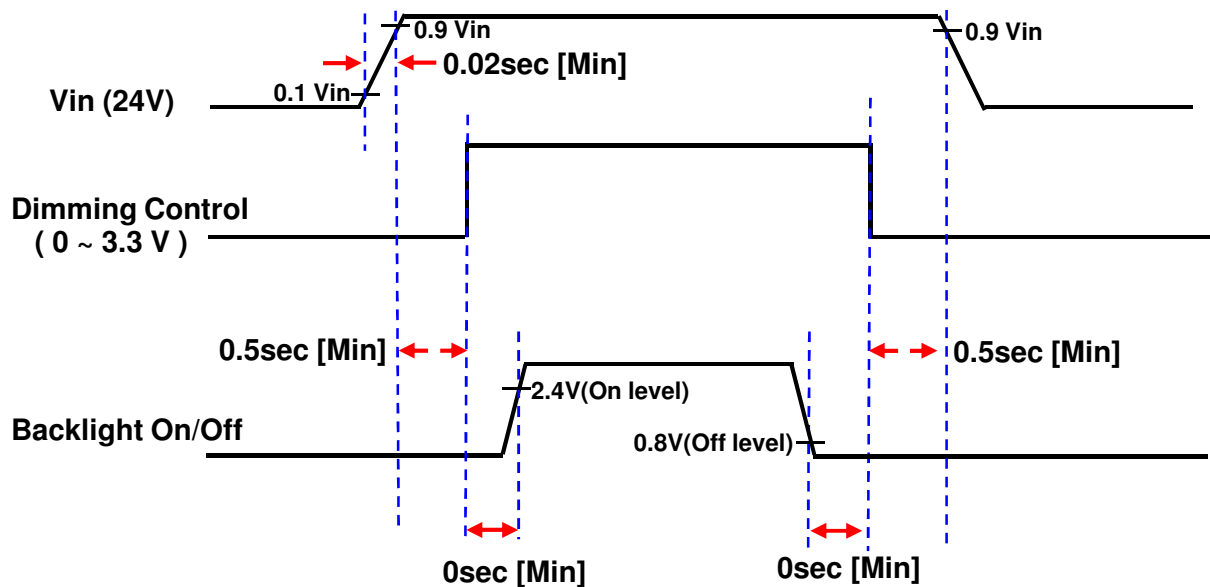

Note) SEQUENCE : On = Vin(24V) > Dimming Control ≥ Backlight On/off
 OFF = Backlight On/Off ≥ Dimming Control > Vin(24V)

5.4 LVDS Interface

- LVDS Receiver : T-con (merged)
- Data Format (JEIDA & VESA)

	LVDS pin	JEIDA -DATA	VESA -DATA
TxOUT/RxIN0	TxIN/RxOUT0	R2	R0
	TxIN/RxOUT1	R3	R1
	TxIN/RxOUT2	R4	R2
	TxIN/RxOUT3	R5	R3
	TxIN/RxOUT4	R6	R4
	TxIN/RxOUT6	R7	R5
	TxIN/RxOUT7	G2	G0
TxOUT/RxIN1	TxIN/RxOUT8	G3	G1
	TxIN/RxOUT9	G4	G2
	TxIN/RxOUT12	G5	G3
	TxIN/RxOUT13	G6	G4
	TxIN/RxOUT14	G7	G5
	TxIN/RxOUT15	B2	B0
	TxIN/RxOUT18	B3	B1
TxOUT/RxIN2	TxIN/RxOUT19	B4	B2
	TxIN/RxOUT20	B5	B3
	TxIN/RxOUT21	B6	B4
	TxIN/RxOUT22	B7	B5
	TxIN/RxOUT24	HSYNC	HSYNC
	TxIN/RxOUT25	VSYNC	VSYNC
	TxIN/RxOUT26	DEN	DEN
TxOUT/RxIN3	TxIN/RxOUT27	R0	R6
	TxIN/RxOUT5	R1	R7
	TxIN/RxOUT10	G0	G6
	TxIN/RxOUT11	G1	G7
	TxIN/RxOUT16	B0	B6
	TxIN/RxOUT17	B1	B7
	TxIN/RxOUT23	RESERVED	RESERVED

5.5 Input Signals, Basic Display Colors and Gray Scale of Each Color

COLOR	DISPLAY	DATA SIGNAL																												GRAY SCALE LEVEL					
		RED									GREEN									BLUE															
		R0	R1	R2	R3	R4	R5	R6	R7	R8	R9	G0	G1	G2	G3	G4	G5	G6	G7	G8	G9	B0	B1	B2	B3	B4	B5	B6	B7		B8	B9			
BASIC COLOR	BLACK	0	0	0	0	0	0	0	0	0	0	0	0	0	0	0	0	0	0	0	0	0	0	0	0	0	0	0	0	0	0	0	0	0	-
	BLUE	0	0	0	0	0	0	0	0	0	0	0	0	0	0	0	0	0	0	0	0	1	1	1	1	1	1	1	1	1	1	1	1	1	-
	GREEN	0	0	0	0	0	0	0	0	0	0	1	1	1	1	1	1	1	1	1	1	0	0	0	0	0	0	0	0	0	0	0	0	0	-
	CYAN	0	0	0	0	0	0	0	0	0	0	1	1	1	1	1	1	1	1	1	1	1	1	1	1	1	1	1	1	1	1	1	1	1	-
	RED	1	1	1	1	1	1	1	1	1	1	0	0	0	0	0	0	0	0	0	0	0	0	0	0	0	0	0	0	0	0	0	0	0	-
	MAGENTA	1	1	1	1	1	1	1	1	1	1	0	0	0	0	0	0	0	0	0	0	1	1	1	1	1	1	1	1	1	1	1	1	1	-
	YELLOW	1	1	1	1	1	1	1	1	1	1	1	1	1	1	1	1	1	1	1	1	0	0	0	0	0	0	0	0	0	0	0	0	0	-
	WHITE	1	1	1	1	1	1	1	1	1	1	1	1	1	1	1	1	1	1	1	1	1	1	1	1	1	1	1	1	1	1	1	1	1	-
GRAY SCALE OF RED	BLACK	0	0	0	0	0	0	0	0	0	0	0	0	0	0	0	0	0	0	0	0	0	0	0	0	0	0	0	0	0	0	0	R0		
	DARK ↑	1	0	0	0	0	0	0	0	0	0	0	0	0	0	0	0	0	0	0	0	0	0	0	0	0	0	0	0	0	0	0	R1		
		0	1	0	0	0	0	0	0	0	0	0	0	0	0	0	0	0	0	0	0	0	0	0	0	0	0	0	0	0	0	0	R2		
		:	:	:	:	:	:	:	:	:	:	:	:	:	:	:	:	:	:	:	:	:	:	:	:	:	:	:	:	:	:	:	:	R3~ R1020	
		:	:	:	:	:	:	:	:	:	:	:	:	:	:	:	:	:	:	:	:	:	:	:	:	:	:	:	:	:	:	:	:	:	
	↓ LIGHT	1	0	1	1	1	1	1	1	1	1	0	0	0	0	0	0	0	0	0	0	0	0	0	0	0	0	0	0	0	0	0	R1021		
		0	1	1	1	1	1	1	1	1	1	0	0	0	0	0	0	0	0	0	0	0	0	0	0	0	0	0	0	0	0	0	R1022		
	RED	1	1	1	1	1	1	1	1	1	1	0	0	0	0	0	0	0	0	0	0	0	0	0	0	0	0	0	0	0	0	0	0	R1023	
GRAY SCALE OF GREEN	BLACK	0	0	0	0	0	0	0	0	0	0	0	0	0	0	0	0	0	0	0	0	0	0	0	0	0	0	0	0	0	0	0	0	G0	
	DARK ↑	0	0	0	0	0	0	0	0	0	0	1	0	0	0	0	0	0	0	0	0	0	0	0	0	0	0	0	0	0	0	0	0	G1	
		0	0	0	0	0	0	0	0	0	0	0	1	0	0	0	0	0	0	0	0	0	0	0	0	0	0	0	0	0	0	0	0	G2	
		:	:	:	:	:	:	:	:	:	:	:	:	:	:	:	:	:	:	:	:	:	:	:	:	:	:	:	:	:	:	:	:	G3~ G1020	
		:	:	:	:	:	:	:	:	:	:	:	:	:	:	:	:	:	:	:	:	:	:	:	:	:	:	:	:	:	:	:	:	:	
	↓ LIGHT	0	0	0	0	0	0	0	0	0	0	1	0	1	1	1	1	1	1	1	1	0	0	0	0	0	0	0	0	0	0	0	G1021		
		0	0	0	0	0	0	0	0	0	0	0	1	1	1	1	1	1	1	1	1	0	0	0	0	0	0	0	0	0	0	0	G1022		
	GREEN	0	0	0	0	0	0	0	0	0	0	1	1	1	1	1	1	1	1	1	1	0	0	0	0	0	0	0	0	0	0	0	0	G1023	
GRAY SCALE OF BLUE	BLACK	0	0	0	0	0	0	0	0	0	0	0	0	0	0	0	0	0	0	0	0	0	0	0	0	0	0	0	0	0	0	0	B0		
	DARK ↑	0	0	0	0	0	0	0	0	0	0	0	0	0	0	0	0	0	0	0	0	1	0	0	0	0	0	0	0	0	0	0	B1		
		0	0	0	0	0	0	0	0	0	0	0	0	0	0	0	0	0	0	0	0	0	1	0	0	0	0	0	0	0	0	0	B2		
		:	:	:	:	:	:	:	:	:	:	:	:	:	:	:	:	:	:	:	:	:	:	:	:	:	:	:	:	:	:	:	:	B3~ B1020	
		:	:	:	:	:	:	:	:	:	:	:	:	:	:	:	:	:	:	:	:	:	:	:	:	:	:	:	:	:	:	:	:	:	
	↓ LIGHT	0	0	0	0	0	0	0	0	0	0	0	0	0	0	0	0	0	0	0	0	1	0	1	1	1	1	1	1	1	1	1	B1021		
		0	0	0	0	0	0	0	0	0	0	0	0	0	0	0	0	0	0	0	0	0	1	1	1	1	1	1	1	1	1	1	B1022		
	BLUE	0	0	0	0	0	0	0	0	0	0	0	0	0	0	0	0	0	0	0	0	1	1	1	1	1	1	1	1	1	1	1	B1023		

Note) Definition of Gray :
 Rn : Red Gray, Gn : Green Gray, Bn : Blue Gray (n = Gray level)
 Input Signal : 0 = Low level voltage, 1 = High level voltage

6. Interface Timing

6.1 Timing Parameters (DE only mode)

SIGNAL	ITEM	SYMBOL	MIN.	TYP.	MAX.	Unit	NOTE
Clock	Frequency	$1/T_C$	130	148.5	153	MHz	-
Hsync		F_H	50	67.5	70	KHz	-
Vsync		F_V	48	60	63	Hz	-
Vertical Display Term	Active Display Period	T_{VD}	-	1080	-	lines	-
	Vertical Total	T_{VB}	1118	1125	1550	lines	-
Horizontal Display Term	Active Display Period	T_{HD}	-	1920	-	clocks	-
	Horizontal Total	T_H	2160	2200	2600	clocks	-

Note) This product is DE only mode. The input of Hsync & Vsync signal does not have an effect on normal operation.

- (1) Test Point : TTL control signal and CLK at LVDS Tx input terminal in system
- (2) Internal VDD = 3.3V

6.2 Timing diagrams of interface signal (DE only mode)

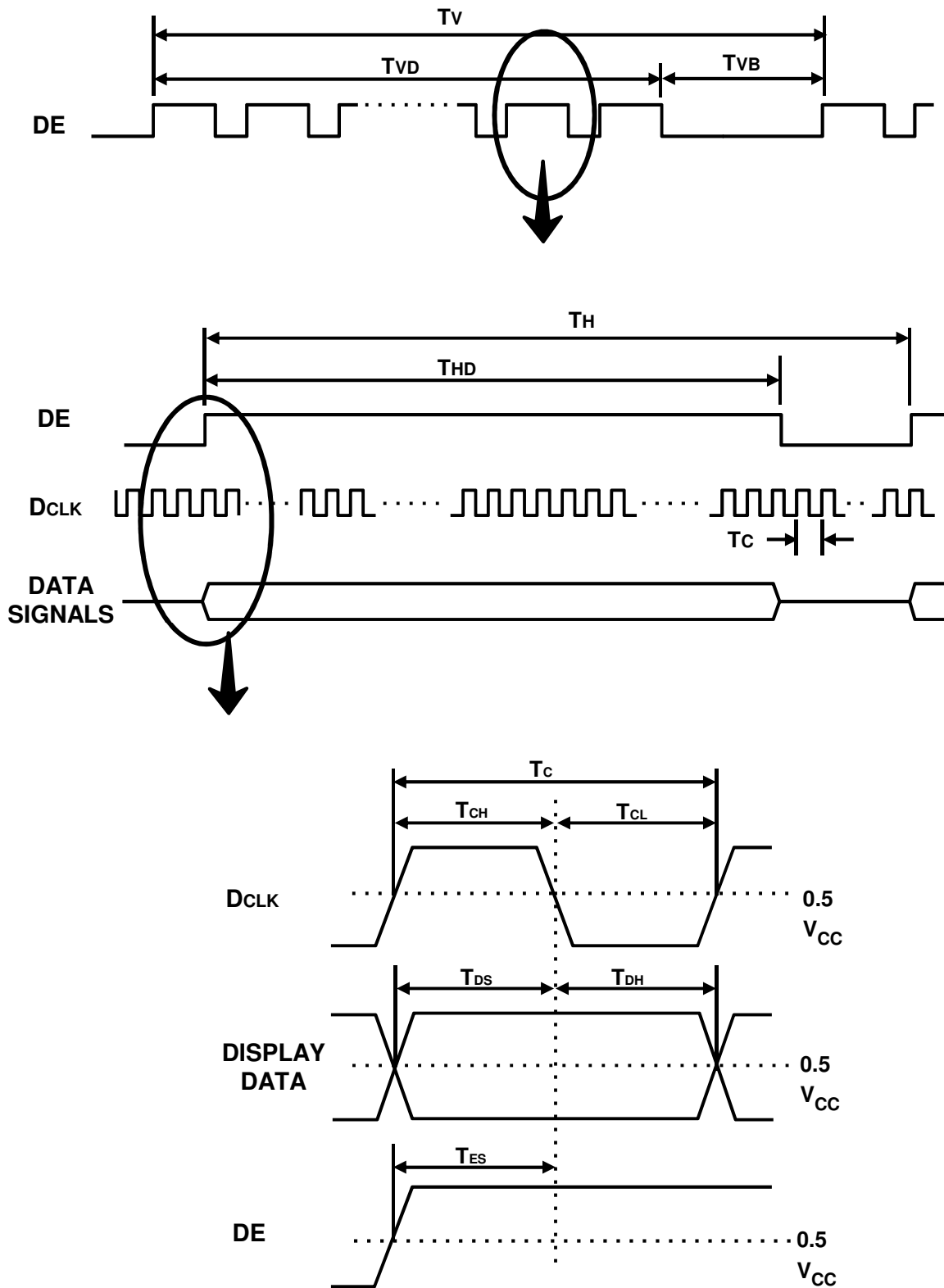

6.3 Power ON/OFF Sequence

To prevent a latch-up or DC operation of the LCD Module, the power on/off sequence should be as the diagram below.

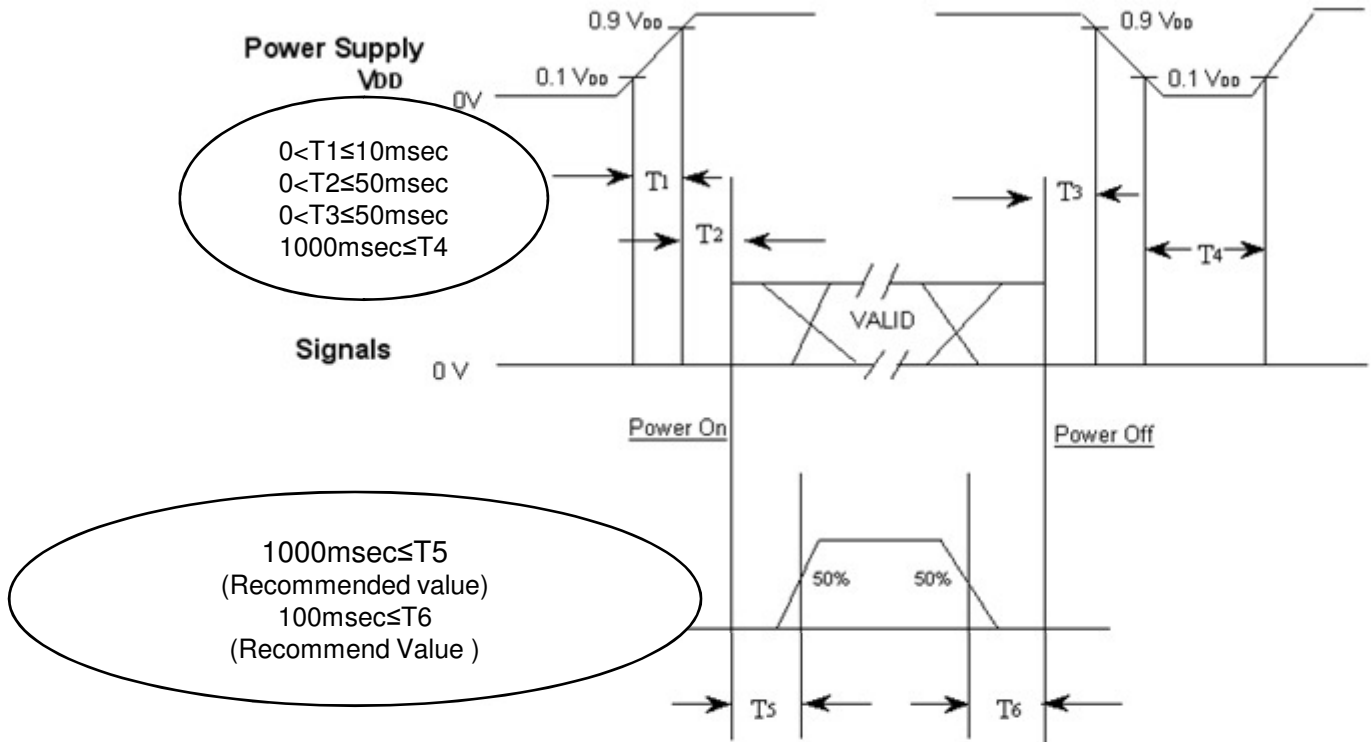

- $T1$: V_{DD} rising time from 10% to 90%
- $T2$: The time from V_{DD} to valid data at power ON.
- $T3$: The time from valid data off to V_{DD} off at power Off.
- $T4$: V_{DD} off time for Windows restart
- $T5$: The time from valid data to B/L enable at power ON.
- $T6$: The time from valid data off to B/L disable at power Off.

- The supply voltage of the external system for the Module input should be the same as the definition of V_{DD} .
- Apply the lamp voltage within the LCD operation range. When the back light turns on before the LCD operation or the LCD turns off before the back light turns off, the display may momentarily show abnormal screen.
- In case of V_{DD} = off level, please keep the level of input signals low or keep a high impedance.
- $T4$ should be measured after the Module has been fully discharged between power off and on period.
- Interface signal should not be kept at high impedance when the power is on.
- In case $T5$ is less than 1000msec and $T6$ is less than 100msec, Garbage Display can be seen. (It is not related to electrical function issue, Just for recommendation to prevent Garbage Display)

NO.	PART NAME	CODE NO.	SPECIFICATION	Q'TY	WEIGHT		UNPAIRED DIM. OF MATERIAL	REMARK
					FINISH	MATERIAL		
	OUTLINE (FRONT)		LTA400AA04/HA07					

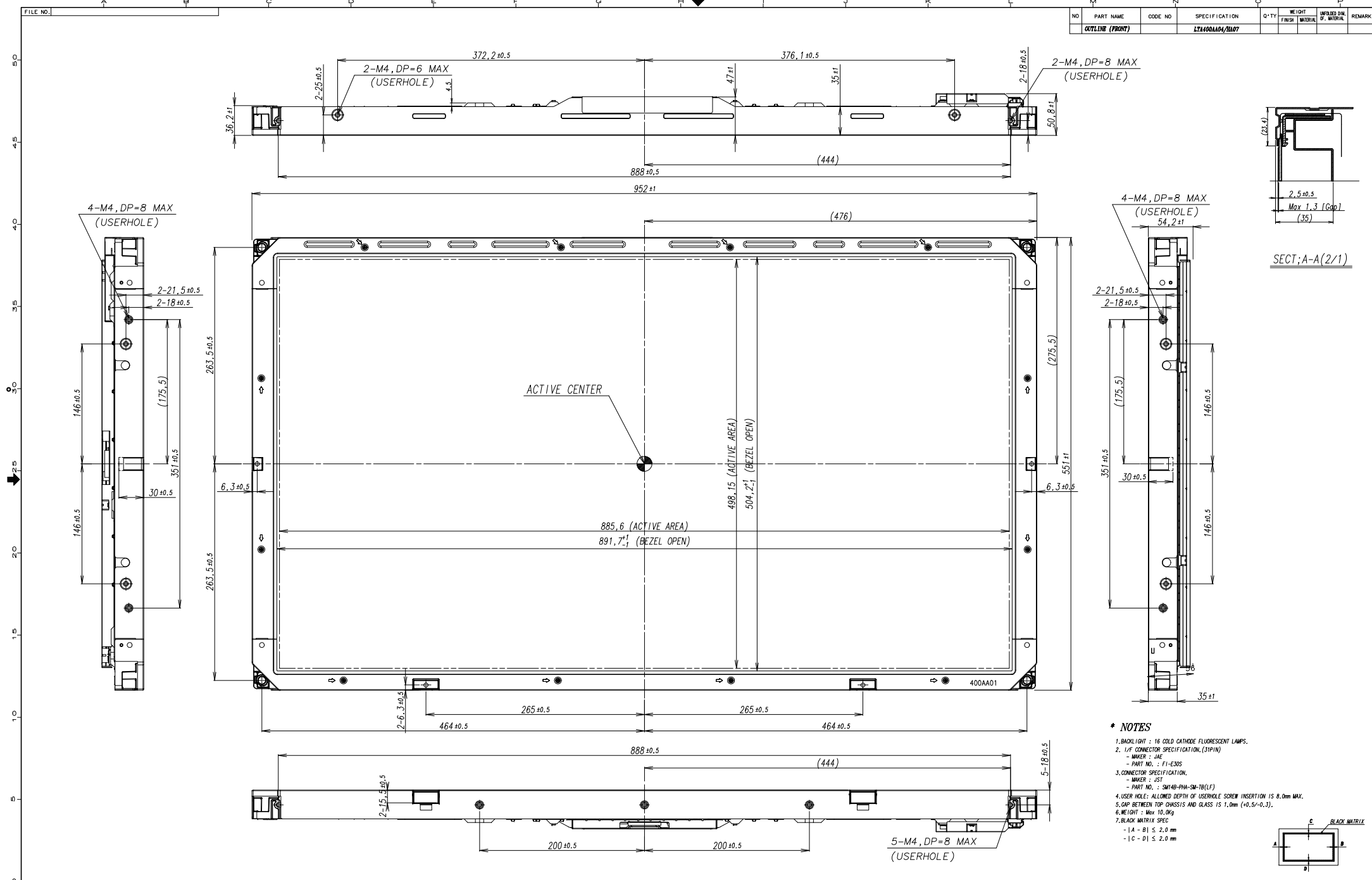

*** NOTES**

- BACKLIGHT : 16 COLD CATHODE FLUORESCENT LAMPS.
- I/F CONNECTOR SPECIFICATION (31PIN)
- MAKER : JAE
- PART NO. : F1-E30S
- CONNECTOR SPECIFICATION.
- MAKER : SST
- PART NO. : SM4B-PIN-SM-16(LF)
- USER HOLE: ALLOWED DEPTH OF USERHOLE SCREW INSERTION IS 8.0mm MAX.
- GAP BETWEEN TOP CHASSIS AND GLASS IS 1.0mm (+0.5,-0.3).
- WEIGHT : Max 10.0kg
- BLACK MATRIX SPEC
- 1A - B1 ≤ 2.0 mm
- 1C - D1 ≤ 2.0 mm

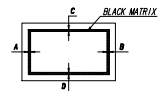

PRELIMINARY

GENERAL TOLERANCE				REV	DATE	DESCRIPTION OF REVISION			REASON	CHK'D BY
STEP	LEVEL 1	LEVEL 2	LEVEL 3	UNIT	mm	DRAWN BY	DES'D BY	CHK'D BY	APP'D BY	
0 < X ≤ 4	±0.05	±0.1	±0.2	SCALE	1:2	J. M. PARK	J. H. WON	J. W. JEON		MODEL NAME
4 < X ≤ 16	±0.08	±0.15	±0.3	TOLERANCE			07.12.21	07.12.21	07.12.21	PART/SHEET NAME
16 < X ≤ 64	±0.12	±0.25	±0.5	LEVEL 3						OUTLINE (FRONT)
64 < X ≤ 256	±0.25	±0.4	±0.8							SHEET 1/2

SAMSUNG ELECTRONICS

NO. 9-0-0

NO.	PART NAME	CODE NO.	SPECIFICATION	Q'TY	WEIGHT T/WGT	MATERIAL	PROCESSING OF MATERIAL	REMARK
	OUTLINE (REAR)		LTA400AA04/HA07					

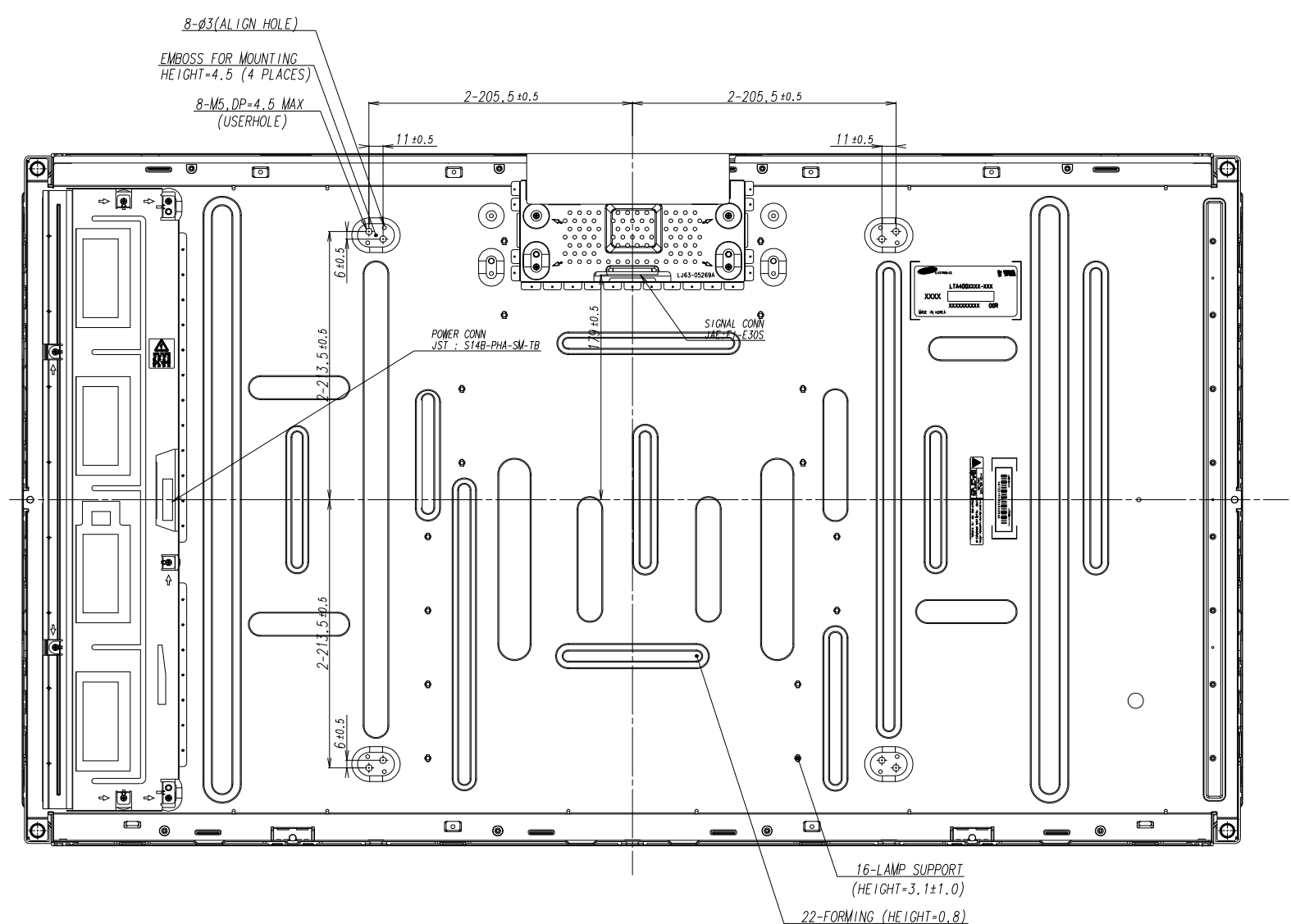

PRELIMINARY

GENERAL TOLERANCE				REV	DATE	DESCRIPTION OF REVISION			REASON	CHK'D BY
STEP	LEVEL 1	LEVEL 2	LEVEL 3	UNIT	DRA'N BY	DES'D BY	CHK'D BY	APP'D BY	MODEL NAME	LTA400AA04/HA07
0 < X ≤ 4	±0.05	±0.1	±0.2	mm	J.M.PARK	J.H.WON	J.H.WON		PART/SHEET NAME	OUTLINE (REAR)
4 < X ≤ 16	±0.08	±0.15	±0.3						SHEET	2/2
16 < X ≤ 64	±0.12	±0.25	±0.5						SPEC. NO.	
64 < X ≤ 256	±0.25	±0.4	±0.8		SAMSUNG ELECTRONICS			CODE NO.		VER. 000

NO. 000-000-000

8. PACKING

7.1 CARTON (Internal Package)

(1) Packing Form

Corrugated fiberboard box and corrugated cardboard as shock absorber

(2) Packing Method

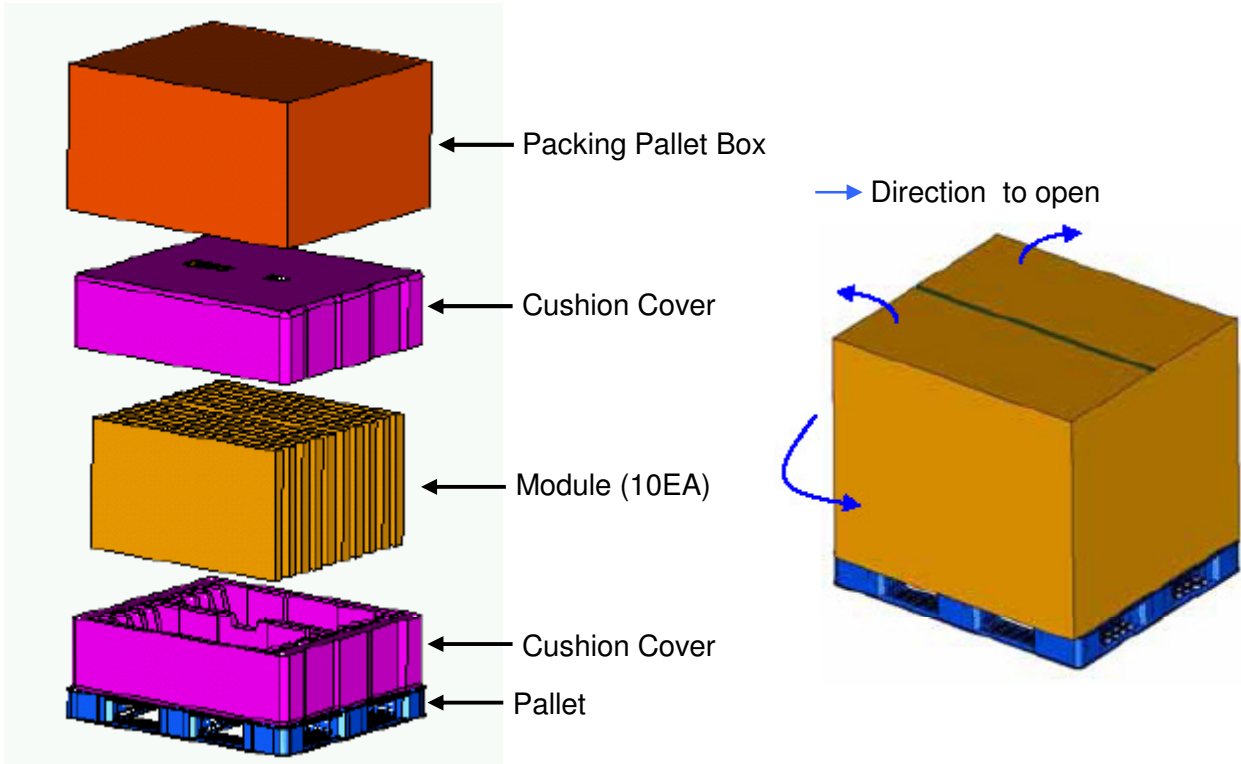

7.2 Packing Specification

Item	Specification	Remark
LCD Packing	10ea / (Packing-Pallet Box)	1. 95Kg / LCD (10ea) 2. 7 Kg / Cushion-pallet (2ea) 3. 6.7 Kg / Packing-Pallet Box (1 ea) 4. Cushion-pallet Material : EPS 5. Packing-Pallet Box Material : DW4
Pallet	1Box / Pallet	1. Pallet weight = 8kg
Packing Direction	Vertical	
Total Pallet Size	H x V x height	1150mm(H) x 985mm(V) x 609mm(height)
Total Pallet Weight	116.7Kg	Pallet(8kg) + Module(95Kg) + Cushion(up+bottom=10kg) + Pallet-BOX(6.7Kg)

9. MARKING & OTHERS

A name plate bearing followed by is affixed to a shipped product at the specified location on each product.

- (1) Parts number : LTA400HA07
- (2) Revision: Three letters
- (3) Lot number : X X X X XXX XX X

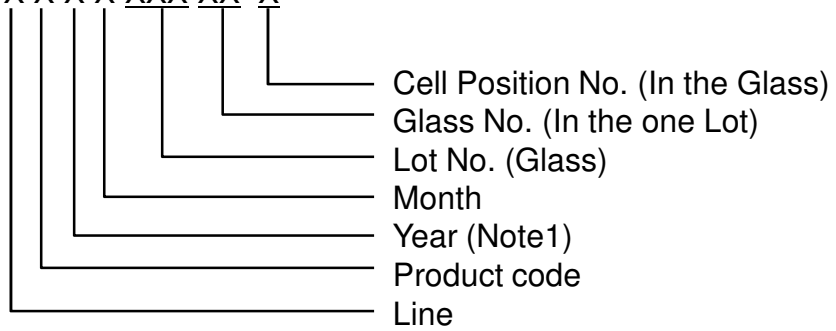

(4) Nameplate Indication

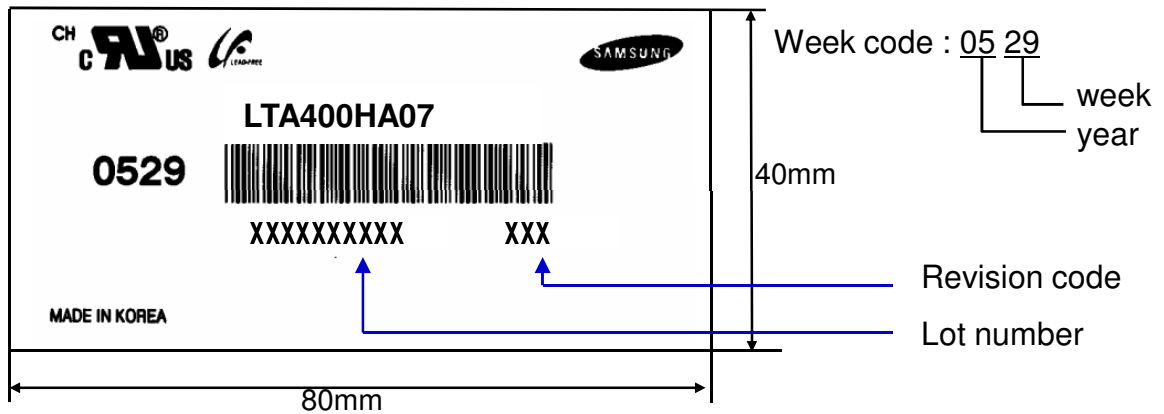

(5) Packing box attach

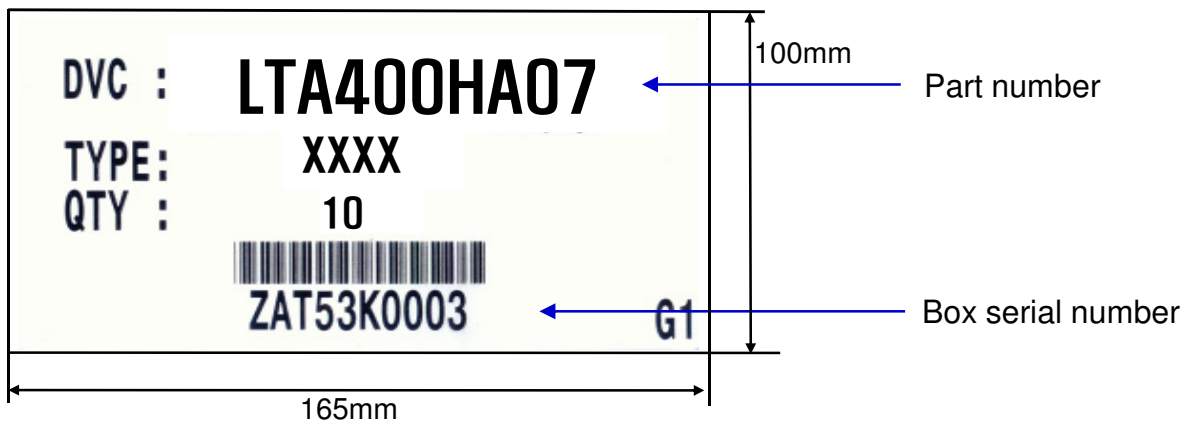

(6) Others

- 1. After service part
 Lamps cannot be replaced because of the narrow bezel structure.

MODEL	LTA400HA07	Doc. No	06-000-G-080111	Page	24 / 27
-------	------------	---------	-----------------	------	---------

10. General Precautions

9.1 Handling

- (a) When the Module is assembled, it should be attached to the system firmly using all mounting holes. Be careful not to twist and bend the Module.
- (b) Because the inverter use high voltage, it should be disconnected from power before it is assembled or disassembled.
- (c) Refrain from strong mechanical shock and / or any force to the Module. In addition to damage, this may cause improper operation or damage to the Module and CCFT back light.
- (d) Note that polarizers are very fragile and could be damage easily. Do not press or scratch the surface harder than a HB pencil lead.
- (e) Wipe off water droplets or oil immediately. If you leave the droplets for a long time, staining or discoloration may occur.
- (f) If the surface of the polarizer is dirty, clean it using absorbent cotton or soft cloth.
- (g) Desirable cleaners are water, IPA(Isopropyl Alcohol) or Hexane. Do not use Ketone type materials(ex. Acetone), Ethyl alcohol, Toluene, Ethyl acid or Methyl chloride. It might permanent damage to the polarizer due to chemical reaction.
- (h) If the liquid crystal material leaks from the panel, it should be kept away from the eyes or mouth . In case of contact with hands, legs or clothes, it must be washed away with soap thoroughly.
- (i) Protect the Module from static, or the CMOS Gate Array IC would be damaged.
- (j) Use finger-stalls with soft gloves in order to keep display clean during the incoming inspection and assembly process.
- (k) Do not disassemble the Module.
- (l) Do not pull or fold the lamp wire.
- (m) Do not adjust the variable resistor located on the Module.
- (n) Protection film for polarizer on the Module should be slowly peeled off just before use so that the electrostatic charge can be minimized.
- (o) Pins of I/F connector should not be touched directly with bare hands.

10.2 Storage

- (a) Do not leave the Module in high temperature, and high humidity for a long time. It is highly recommended to store the Module with temperature from 0 to 35 °C and relative humidity of less than 70%.
- (b) Do not store the TFT-LCD Module in direct sunlight.
- (c) The Module should be stored in a dark place. It is prohibited to apply sunlight or fluorescent light in storing.

10.3 Operation

- (a) No Connection or disconnect the Module in the "Power On" condition.
- (b) Power supply should always be turned on/off by the "Power on/off sequence"
- (c) Module has high frequency circuits. Sufficient suppression to the electromagnetic interference should be done by system manufacturers. Grounding and shielding methods may be important to minimize the interference.
- (d) The cable between the back light connector and its inverter power supply should be connected directly with a minimized length. A longer cable between the back light and the inverter may cause lower luminance of lamp(CCFT) and may require higher startup voltage(Vs).

10.4 Operation Condition Guide

- (a) The LCD product should be operated under normal conditions.
Normal condition is defined as below;
 - Temperature : 20 ± 15 °C
 - Humidity : 55 ± 20 %
 - Display pattern : continually changing pattern (Not stationary)
- (b) If the product will be used in extreme conditions such as high temperature, humidity, display patterns or operation time etc., It is strongly recommended to contact SEC for Application engineering advice. Otherwise, its reliability and function may not be guaranteed. Extreme conditions are commonly found at Airports, Transit Stations, Banks, Stock market, and Controlling systems.

10.5 Others

- (a) Ultra-violet ray filter is necessary for outdoor operation.
- (b) Avoid condensation of water. It may result in improper operation or disconnection of electrode.
- (c) Do not exceed the absolute maximum rating value. (supply voltage variation, input voltage variation, variation in part contents and environmental temperature, and so on)
Otherwise the Module may be damaged.
- (d) If the Module keeps displaying the same pattern for a long period of time, the image may be "sticked" to the screen.
To avoid image sticking, it is recommended to use a screen saver.
- (e) This Module has its circuitry PCB's on the rear side and should be handled carefully in order not to be stressed.
- (f) Please contact SEC in advance when you display the same pattern for a long time.