



TFT-LCD MONITOR

Product Information

(Temporary)

MODEL NO. : T190E1D1 v.0H

Date : 2008.03.24 Revision 0.2

Prepared by : *Nicolas Shih*

Nicolas Hsih, Engineer, Product Development Div.

Approved by : *Jackey Chien*

Jackey Chien, Director, Product Development Div.

This TFT LCD Monitor is distributed by:



Display Solution AG
Talhofstraße 32a
D-82205 Gilching
GERMANY
Fon +49 (0)8105 / 73 403 - 0
Fax +49 (0)8105 / 73 403 - 79
E-Mail: info@display-solution.com
Internet: www.display-solution.com

This product specification is subject to change without any notice.



Records of Revision

Date	Rev. No.	Summary	Page
2009.02.27	0.1	First Release	1
2009/3/24	0.2	DWG of LCD Module and B/L + Heater Driver Added	18/19/20



Contents	Page
1.0 Handling Precautions	4
2.0 General Description	5
2.1 General Application	5
2.2 Main Features	5
2.3 General Information	5
2.3.1 Display Characteristics	5
2.3.2 Mechanical Dimensions	6
3.0 Absolute Maximum Ratings	6
3.1 Absolute Ratings of Environment Requirement	6
3.2 Electrical Absolute Ratings	7
3.2.1 TFT-LCD Module	7
3.2.2 Backlight Module(LED)	7
4.0 Optical Characteristics	8
5.0 Electrical Characteristics	10
5.1 AC Timing Characteristics	10
5.2 DC Characteristics	10
5.2.1 TFT-LCD Module	10
5.2.2 Backlight Unit & LED Driver	11
5.3 Input Terminal Pin Assignment	11
5.3.1 Signal Input Interface	11
5.3.2 LED Driver Unit	12
5.3.3 Color Data Reference	13
5.4 Input Timing Chart	15
6.0 Pixel Format Image	16
7.0 Display Outline Dimensions	16
8.0 Labeling, Packaging & Others	20
9.0 General Notices	22
9.1 Reliability Test Item	22
9.2 Storage, Operation & Others	23



1.0 Handling Precaution

- 1.) Handle with care. Pay attention not to press or scratch the surface of the monitor, especially the polarizer. Do not twist or bend the monitor. It may cause un-recoverable damage.
- 2.) Do not drop or bump the monitor since this monitor contains fragile glass components. Breakage of this monitor might cause leakage of the liquid crystal sealed inside the glasses. Do not touch the liquid crystal liquid in case of leakage. **Flush with massive water immediately in case of contact with your skin by liquid crystal fluid and call for doctor for immediate medical treatment.**
- 3.) Be sure to turn off power supply while plug or un-plug the power input connector.
- 4.) Clean up the polarizer only with soft solvent if necessary. The desirable cleaners are water, IPA(Isopropyl Alcohol) or Hexane. Do not use Ketone type materials (ex. Acetone), Ethyl alcohol, toluene, Ethyl acid or Methyl chloride. It will permanently damage the polarizer due to chemical reaction. 5.) Wipe off fluid drop immediately to prevent from possible discoloration or spots on the polarizer.
- 6.) Do not twist nor bend the monitor structure, even momentarily. Bending or twisting torque may likely damage the internal components of the monitor.
- 7.) Protect the monitor from static environment to prevent from damage to the CMOS gate array IC.



2.0 General Description

T1910E1D1 v.0H is a 19 inch (5:4 aspect ratio) color active matrix TFT LCD monitor with excellent display performance driven by a pure **DIGITAL** LVDS interface assembled in a compact and slim **LED backlight** unit which is also heater embedded. This LCD supports 1280(H) x RGB x 1024(V) stripe color pixel format and 16.7M colors (RGB 8 bits) with vivid color image. Its outstanding performances with high color saturation of 72%, high brightness, **300 nits(typ.)**, super wide viewing angle(160°/160°), ultra high contrast ratio 800:1, and excellent liquid crystal response time under extremely low temperature environment make this LCD module very suitable for terminal and video applications in the severely cold environment.

2.1 General Applications

- Display terminal for applications of Video, Industrial, Medical, Gaming, Advertisement or more.

2.2 Main Features

- 5:4 1280 x RGB x 1024 Display Aspect Ratio
- LED Backlight
- Good Brightness of 300 nits
- Excellent Brightness, 300 nits, and Response Time at Low Temperature @ -30 °C
- Extremely Wide Dimming Range
- Super Wide Viewing Angle
- High Contrast Ratio
- High Color Saturation of 72%
- Pure 2ch Digital LVDS (Low Voltage Differential Signaling) Interface
- DE (Data Enable) Mode
- All-in-one Design, LED driver Enclosed
- RoHS Compliance & High Safety Product

2.3 General Information

2.3.1 Display Characteristics

Item	Specification	Unit	Note
Display Area (HxV)	376.3 x 301.1	mm	19" Diagonal
Driver Element	a-Si TFT Active Matrix	-	-
Number of Pixels (HxV)	1280 x RGB x 1024	pixel	Std. 5:4
Pixel Arrangement	R.G.B Vertical Stripe	-	-
Dot Pitch (HxV)	(0.098x3) x 0.294	mm	Dot



Viewing Angle (H/V)	160/160	degree	6 o'clock
Signal Interface	Digital RGB 24 bits (2 ch LVDS)		16.7M colors
Display Mode	Normally White	-	-

5.2.1 Mechanical Dimensions

Item	Min.	Typ.	Max.	Unit	Note
Dimension	Horizontal	396.0		mm	±0.5 mm
	Vertical	324.0			±0.5 mm
	Depth	-	17.5		Note 1
Weight	-	-	2500	g	±10 g

Note 1: The LED driver and heater driver are provided as separated board, the dimension specified here does not include this part.

3.0 Absolute Maximum Ratings

3.1 Absolute Ratings of Environment Requirement

Item	Symbol	Min.	Max.	Unit	Note
Storage Temperature	Tstg	-30	+70	°C	
Operation Temperature (Ambient Temperature)	Top	-30	+60	°C	(2)

Note (1) Temperature and relative humidity range are shown in the figure below.

95% RH Max. ($40^{\circ}\text{C} > T_a$)

Maximum wet – bulb temperature at 39°C or less. ($T_a > 40^{\circ}\text{C}$) No condensation.

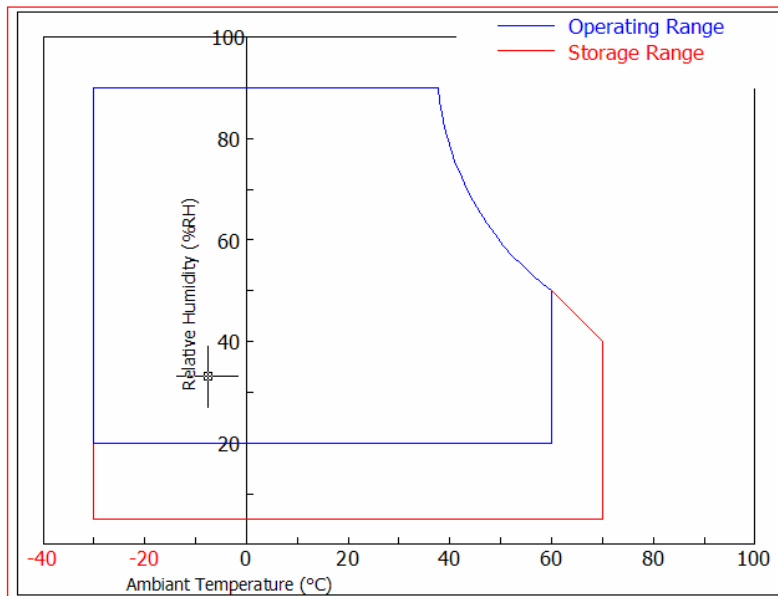

Note(2) : Uniformity might be degraded below -20°C .



3.2 Electrical Absolute Ratings

3.2.1 TFT-LCD Module

(Ta=25±2°C), GND=0V)

Item	SYMBOL	Min.	Max.	UNIT	NOTE
Power Supply Voltage	V _{CC-in}	-0.3	5.5	V	(1),(2)

3.2.2 Backlight Module(LED Driver)

Item	SYMBOL	MIN	MAX	UNIT	NOTE
Input DC Voltage	V _{BL}		15	V	(1),(2)

3.2.3 Heater Driver

Item	SYMBOL	MIN	MAX	UNIT	NOTE
Input DC Voltage	V _{HT}		15	V	(1),(2)

Note (1) Within operating temperature

Note (2) Permanent damage to the device may occur if maximum values are exceeded.

Functional operation should be restricted to the conditions described under normal operating conditions.



4.0 Optical Characteristics

The following items are measured under stable conditions in a dark room or equivalent state.

3.2.4 Measuring Equipment: BM-5A, PR-650

($V_{cc-in}=5V$, $f_v=60Hz$, $T_a=25\pm 2^\circ C$)

Item	Symbol	Condition	Min.	Typ.	Max.	Unit	Note
Contrast Ratio	CR	At optimized Viewing Angle	600	800	-	-	(1)(2) (4)
Response Time at 25°C	Rising	$\theta=0^\circ$	-	15	-	ms	(3)
	Falling		-	5	-		
Luminance(center)	Y_L	$V_{DIM}=max$	230	300	-	cd/m ²	(1)(2) (6)
Viewing Angle	Hor.	θ_L	CR \geq 10 at center point	80	-	Degree	(2)(5)
		θ_R		80	-		
	Ver.	θ_H		80	-		
		θ_L		80	-		
White Uniformity	δ_w		0.75			%	(2)(7)

Note (1) : Ambient temperature =25°C, and , using the Mode 2 of LED control scheme and $V_{DIM}=0V$ to get the maximum brightness. To be measured in the dark room.

Note (2) : To be measured on the center area of panel with a viewing cone of 1° by Topcon Luminance Meter BM-5, after 10 minutes operation.

Note (3) : Definition of response time:

The output signals of photo detector are measured when the input signals are changed from “black” to “white”(falling time) and from “white” to “black”(rising time), respectively.

The response time is defined as the time interval between the 10% and 90% of amplitudes. Refer to figure as below.

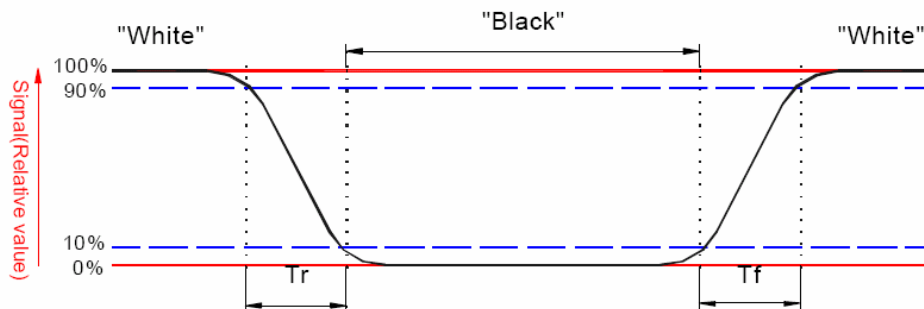

Note (4) : Definition of contrast ratio:

Contrast ratio is calculated with the following formula.

$$\text{Contrast ratio (CR)} = \frac{\text{Photo detector output when LCD is at "White" state}}{\text{Photo detector output when LCD is at "Black" state}}$$

Note (5) : Definition of viewing angle, Refer to figure as below.

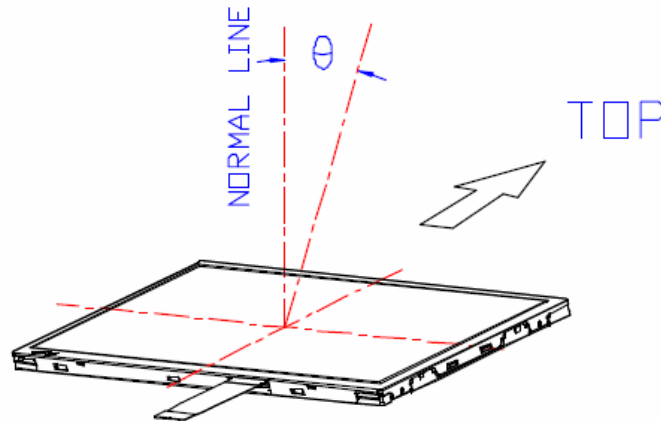

Note (6) : Measured at the center area of the panel when all the input terminals of LCD panel are electrically opened.

Note (7) : Definition of White Uniformity :

Luminance is measured at the following 9 points.

$$\Delta_w = \frac{\text{Minimum Brightness of 9 points}}{\text{Maximum Brightness of 9 points}}$$

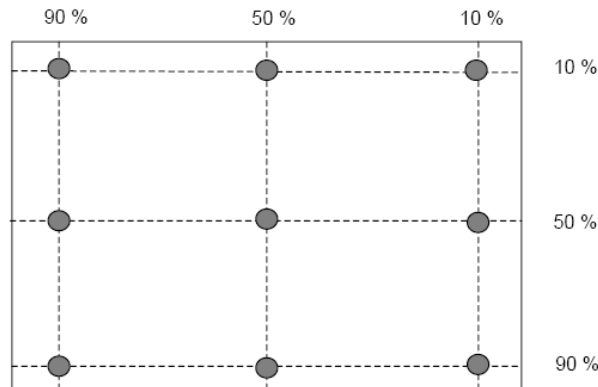

5.0 Electrical Characteristics

5.1 AC Timing Characteristics

Signal	Item	Symbol	Min.	Typ.	Max.	Unit	Note
LVDS Clock	Frequency	Fc	45	54	68	MHz	-
	Period	Tc	14.71	18.52	22.22	ns	-
Vertical Active Display Term	Frame Rate	Fr	56	60	75	Hz	Tv=Tvd+Tvb
	Total	Tv	1044	1066	1300	Th	-
	Display	Tvd	1024	1024	1024	Th	-
	Blank	Tvb	20	42	Tv-Tvd	Th	-
Horizontal Active Display Term	Total	Th	710	844	980	Tc	Th=Thd+Thb
	Display	Thd	640	640	640	Tc	-
	Blank	Thb	70	204	Th-Thd	Tc	-

Note : (1) Hsync and Vsync input signals should be set to low logic level or ground because this LCD module is operated by "DE only" mode. Otherwise, this module would operate abnormally.

5.2 DC Characteristics

5.2.1 TFT-LCD Module

Item	Symbol	Min.	Typ.	Max.	Unit	Note
Power Supply	V_{cc-in}	4.5	5.0	5.5	V	(1)
	I_{cc-in}	-	1.5	1.7	A	$V_{cc-in}=+5V$
Permissive Input Ripple Voltage	V_{RF}	100	-	-	mV _{P-P}	$V_{cc-in}=+5V$
Differential Impedance	Z_m	90	100	110	ohm	
LVDS Differential Input Voltage	Vid	-100	-	100	mV	
LVDS Common Input Voltage	Vic	1.125	1.25	1.375	V	

Note (1) V_{cc-in} Power-On Condition :

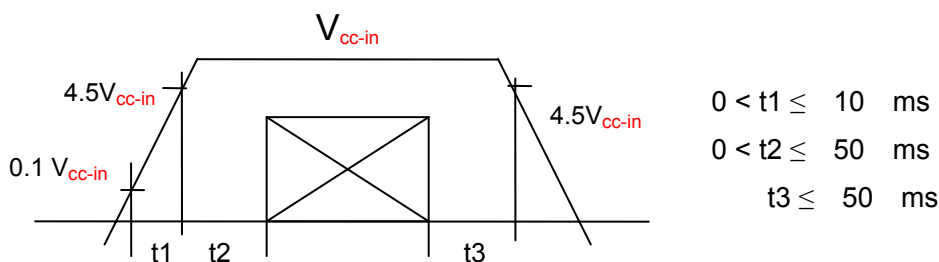



5.2.2 Backlight Unit & LED Driver

Item	Symbol	Min.	Typ.	Max.	Unit	Note
Power Supply	V_{BL}	10.8	12	13.2	V	Note 1
	I_{BL}	-	1.5	-	Amp	Note 2
Backlight Life Time			50,000		hour	Note 3

Note (1) V_{BL} Power-On Condition for LED driver :

Please make sure the control signals for LED driver must arrive after the power supply of LED driver, V_{BL} .

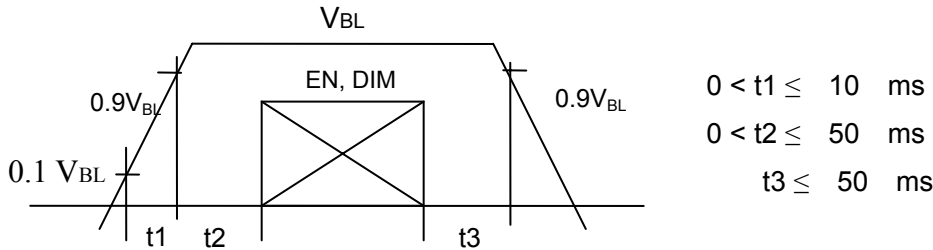

Note (2) : $V_{BL} = 12V$, using the Mode 2 of LED control scheme and $V_{DIM} = 0V$ to get the maximum brightness.

Note (3) : Since LED is consumables, the backlight life time stated in the above list is referential value and is not guaranteed by PowerView. The LED life time is defined as when brightness becomes 50% of the original value that is applied under continuous turning on at the typical value of the power supplied into the backlight, as defined above, at +25°C in a stable environment.

5.2.3 Heater Driver

Item	Symbol	Min.	Typ.	Max.	Unit	Note
Power Supply	V_{HT}	10.8	12	13.2	V	
	I_{HT} (Heater ON)	-	(1.65)	-	Amp	Note 1
	I_{HT} (Heater OFF)	-	0	-	Amp	

Note (1) The embedded heater will be turned on automatically if the internal temperature of LCD module below 5°C. There is thermal sensor built inside the LCD module and a MCU on the heater driver board will sense the temperature and control the heater ON and OFF automatically.



5.3 Input Terminal Pin Assignment

5.3.1 Signal Input Interface

JAE Connector: 30 pin/1 mm pitch JAE-FI-X30SSL-HF

Mating Connector : JAE FI-XB30SSL-HF15 or equivalent

Pin No	Symbol	Description	Remark
1	RxO0-	LVDS receiver signal channel 0 (Odd ch)	
2	RxO0+		
3	RxO1-	LVDS receiver signal channel 1 (Odd ch)	
4	RxO1+		
5	RxO2-	LVDS receiver signal channel 2 (Odd ch)	
6	RxO2+		
7	GND	Ground	
8	RxOC-	LVDS receiver signal clock (Odd ch)	
9	RxOC+		
10	RxO3-	LVDS receiver signal channel 3 (Odd ch)	
11	RxO3+		
12	RxE0-	LVDS receiver signal channel 0 (Even ch)	
13	RxE0+		
14	GND	Ground	
15	RxE1-	LVDS receiver signal channel 1 (Even ch)	
16	RxE1+		
17	GND	Ground	
18	RxE2-	LVDS receiver signal channel 2 (Even ch)	
19	RxE2+		
20	RxEC-	LVDS receiver signal clock (Even ch)	
21	RxEC+		
22	RxE3-	LVDS receiver signal channel 3 (Even ch)	
23	RxE3+		
24	GND	Ground	
25	GND	Ground	
26	NC	No Connection	
27	GND	Ground	
28	V _{cc_IN}	Power supply (+5V)	
29	V _{cc_IN}	Power Supply (+5V)	
30	V _{cc_IN}	Power Supply (+5V)	



5.3.2 LED Driver Unit (CN701)

Connector : ACES 88290-0601 pitch 2.0mm 6 pins CN Or JST S6B-PH-K-S

Mode 1 :

Matching Connector : ACES 86809-0600 CN

Pin No.	Symbol	Description	Remark
1	V _{BL}	Power Supply for LED Driver	
2	V _{BL}	Power Supply for LED Driver	
3	EN	LED Enable & Dimming Control Input	Note 1
4	DIM	Connect this pin to GND at this mode	Note 2
5	GND	Ground Pin for LED Driver	
6	GND	Ground Pin for LED Driver	

Note 1 : The “Enable & Dimming Control” of the LED driver shares the same pinning.

The LED backlight will turn on when the input voltage of this pin exceeds +0.6V.

The LED current/brightness will be adjustable by applying an analog voltage between +0.8 ~ +1.4V(Max. Brightness).

Note 2: The “DIM” pin should be connected to GND in order to get the full brightness.

Mode 2:

Pin No.	Symbol	Description	Remark
1	V _{BL}	Power Supply for LED Driver	
2	V _{BL}	Power Supply for LED Driver	
3	EN	LED Enable Control Input	Note 1
4	DIM	Dimming Control Input	Note 2
5	GND	Ground Pin for LED Driver	
6	GND	Ground Pin for LED Driver	

Note 1 : Disable V_{EN}<0.6 V, Enable V_{EN}>1.8 V

Note 2 : Max Brightness V_{DIM} : 0V, Min Brightness V_{DIM} : 2.2V (≈ 0 Nit)

Mode 3:

Pin No.	Symbol	Description	Remark
1	V _{BL}	Power Supply for LED Driver	
2	V _{BL}	Power Supply for LED Driver	
3	EN	PWM Control Pulse Input	Note 1, 2
4	DIM	Connect this pin to GND at this mode	Note 3
5	GND	Ground Pin for LED Driver	
6	GND	Ground Pin for LED Driver	

Note 1: Valley of PWM Pulse V_{PWM}<0.6 V, Peak of PWM Pulse V_{PWM} >1.8 V

Note 2: The frequency of each completed PWM cycle: 100~300 Hz

Note 3: The “DIM” pin should be connected to GND in order to get the full brightness.



5.3.3 Heater Driver Unit (CN705)

Connector : ACES 88290-0401 pitch 2.0mm 4 pins CN

Or JST S4B-PH-K-S

Mode 1 :

Matching Connector : ACES 86809-0400 CN

Pin No.	Symbol	Description	Remark
1	V _{HT}	Power Supply for Heater Driver	
2	V _{HT}	Power Supply for Heater Driver	
3	GND	Ground Pin for Heater Driver	
4	GND	Ground Pin for Heater Driver	

5.3.4 Color Data Reference

The below table is about nput signal, Basic display colors and gray scale of each color.

0 : Low Level Voltage 1 : High Level Voltage

Each basic color can be displayed in 256 gray scales from 8 bit data signals. With the combination of total 24 bit data signals, the 16,777,216 color display can be achieved on the screen.

- Please refer to the next page



	Colors & Gray Scale	Data Signal																							
		Gray Scale	R0 R1 R2 R3 R4 R5 R6 R7	G0 G1 G2 G3 G4 G5 G6 G7	B0 B1 B2 B3 B4 B5 B6 B7																				
Basic Color	Black	-	0 0 0 0 0 0 0 0	0 0 0 0 0 0 0 0	0 0 0 0 0 0 0 0																				
	Blue	-	0 0 0 0 0 0 0 0	0 0 0 0 0 0 0 0	1 1 1 1 1 1 1 1																				
	Green	-	0 0 0 0 0 0 0 0	1 1 1 1 1 1 1 1	0 0 0 0 0 0 0 0																				
	Cyan	-	0 0 0 0 0 0 0 0	1 1 1 1 1 1 1 1	1 1 1 1 1 1 1 1																				
	Red	-	1 1 1 1 1 1 1 1	0 0 0 0 0 0 0 0	0 0 0 0 0 0 0 0																				
	Magenta	-	1 1 1 1 1 1 1 1	0 0 0 0 0 0 0 0	1 1 1 1 1 1 1 1																				
	Yellow	-	1 1 1 1 1 1 1 1	1 1 1 1 1 1 1 1	0 0 0 0 0 0 0 0																				
	White	-	1 1 1 1 1 1 1 1	1 1 1 1 1 1 1 1	1 1 1 1 1 1 1 1																				
Gray Scale of Red	Black	GS0	0 0 0 0 0 0 0 0	0 0 0 0 0 0 0 0	0 0 0 0 0 0 0 0																				
	↑	GS1	1 0 0 0 0 0 0 0	0 0 0 0 0 0 0 0	0 0 0 0 0 0 0 0																				
	Darker	GS2	0 1 0 0 0 0 0 0	0 0 0 0 0 0 0 0	0 0 0 0 0 0 0 0																				
	↑	↓																							
	↓	↓																							
	Brighter	GS253	1 0 1 1 1 1 1 1	0 0 0 0 0 0 0 0	0 0 0 0 0 0 0 0																				
	↓	GS254	0 1 1 1 1 1 1 1	0 0 0 0 0 0 0 0	0 0 0 0 0 0 0 0																				
	Red	GS255	1 1 1 1 1 1 1 1	0 0 0 0 0 0 0 0	0 0 0 0 0 0 0 0																				
Gray Scale of Green	Black	GS0	0 0 0 0 0 0 0 0	0 0 0 0 0 0 0 0	0 0 0 0 0 0 0 0																				
	↑	GS1	0 0 0 0 0 0 0 0	1 0 0 0 0 0 0 0	0 0 0 0 0 0 0 0																				
	Darker	GS2	0 0 0 0 0 0 0 0	0 1 0 0 0 0 0 0	0 0 0 0 0 0 0 0																				
	↑	↓																							
	↓	↓																							
	Brighter	GS253	0 0 0 0 0 0 0 0	1 0 1 1 1 1 1 1	0 0 0 0 0 0 0 0																				
	↓	GS254	0 0 0 0 0 0 0 0	0 1 1 1 1 1 1 1	0 0 0 0 0 0 0 0																				
	Green	GS255	0 0 0 0 0 0 0 0	1 1 1 1 1 1 1 1	0 0 0 0 0 0 0 0																				
Gray Scale of Blue	Black	GS0	0 0 0 0 0 0 0 0	0 0 0 0 0 0 0 0	0 0 0 0 0 0 0 0																				
	↑	GS1	0 0 0 0 0 0 0 0	0 0 0 0 0 0 0 0	1 0 0 0 0 0 0 0																				
	Darker	GS2	0 0 0 0 0 0 0 0	0 0 0 0 0 0 0 0	0 1 0 0 0 0 0 0																				
	↑	↓																							
	↓	↓																							
	Brighter	GS253	0 0 0 0 0 0 0 0	0 0 0 0 0 0 0 0	1 0 1 1 1 1 1 1																				
	↓	GS254	0 0 0 0 0 0 0 0	0 0 0 0 0 0 0 0	0 1 1 1 1 1 1 1																				
	Blue	GS255	0 0 0 0 0 0 0 0	0 0 0 0 0 0 0 0	1 1 1 1 1 1 1 1																				

This specification data sheet is an intellectual property of PowerView Display Corporation. Any copy, reproduction or modification without written permission of PowerView Display Corporation is not allowed.

5.4 Input Timing Chart

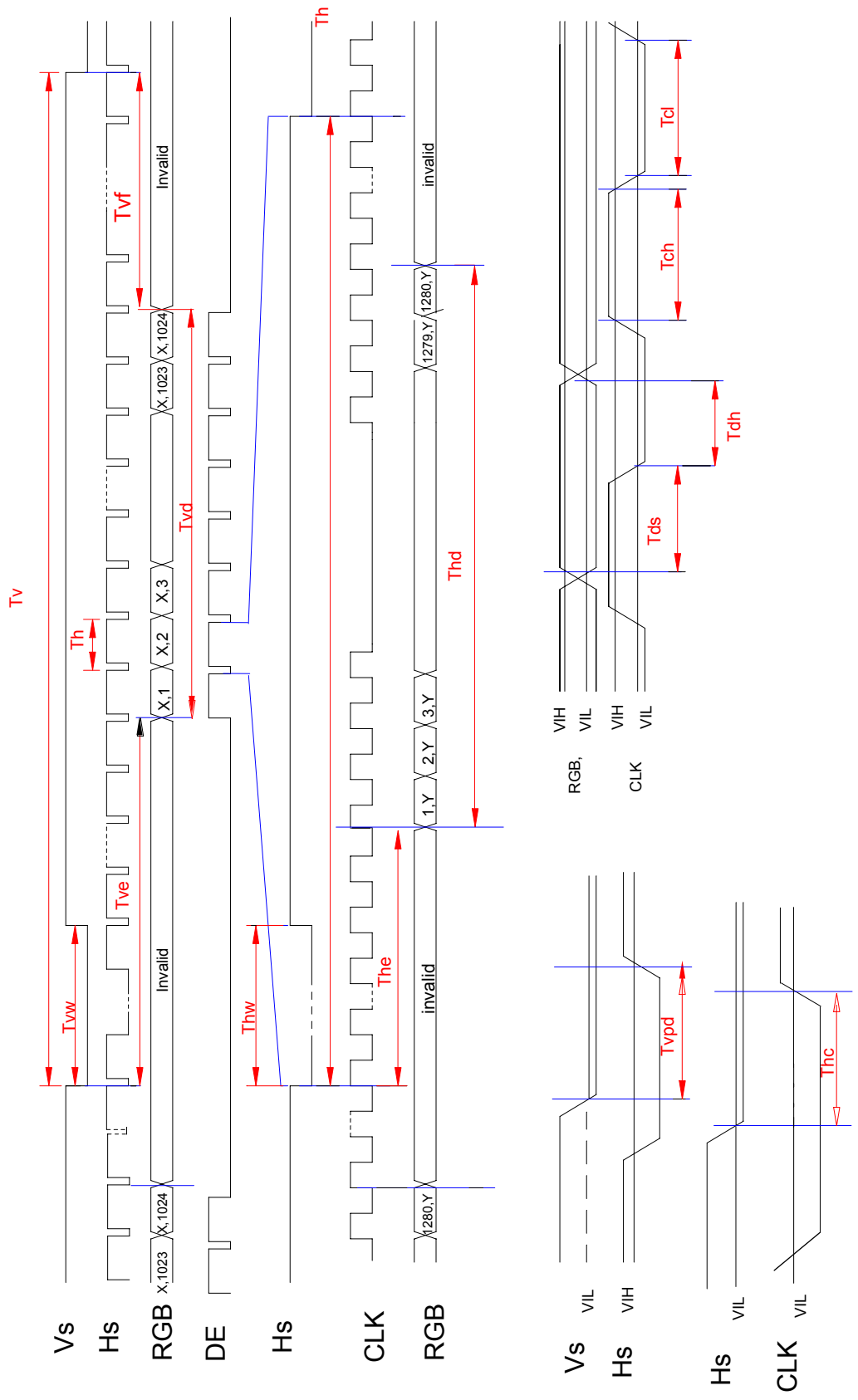



6.0 Pixel Format Image

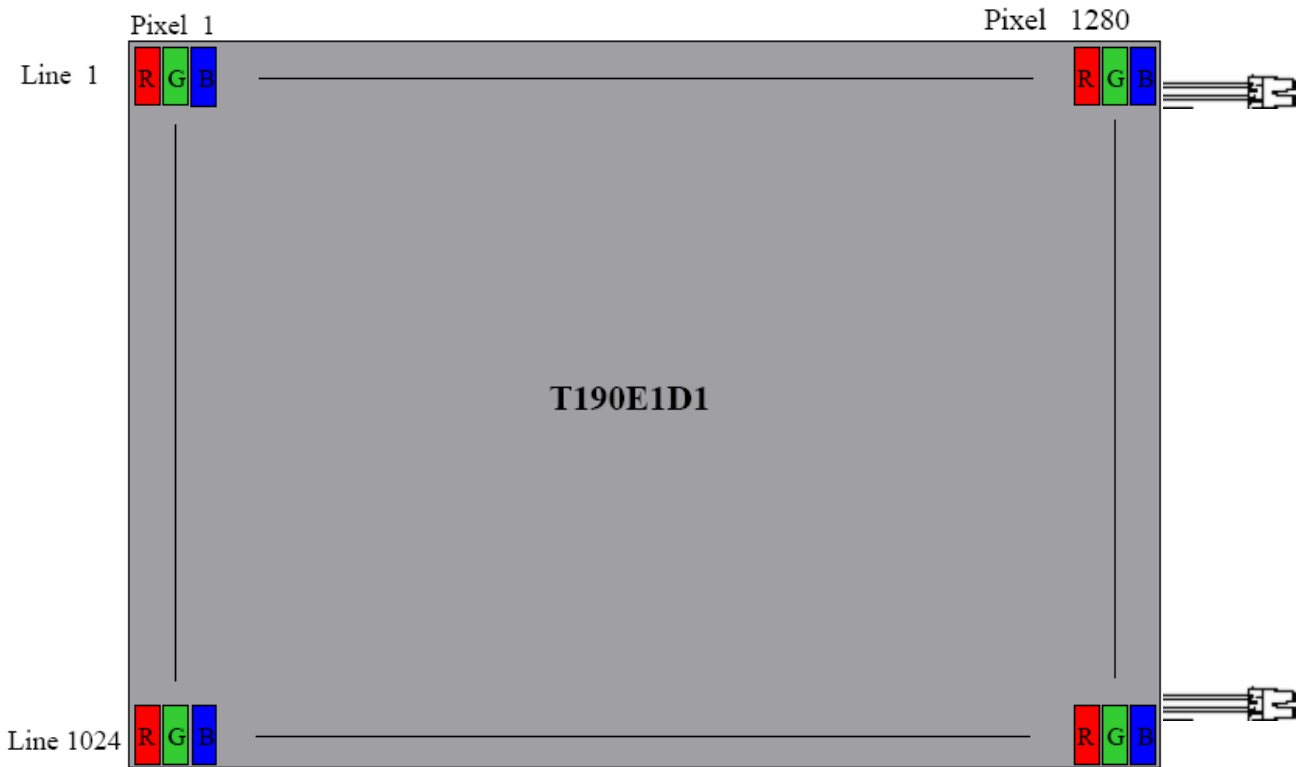

7.0 Display Outline Dimensions

7.1 Monitor Outline Dimensions

- Please refer to the next page

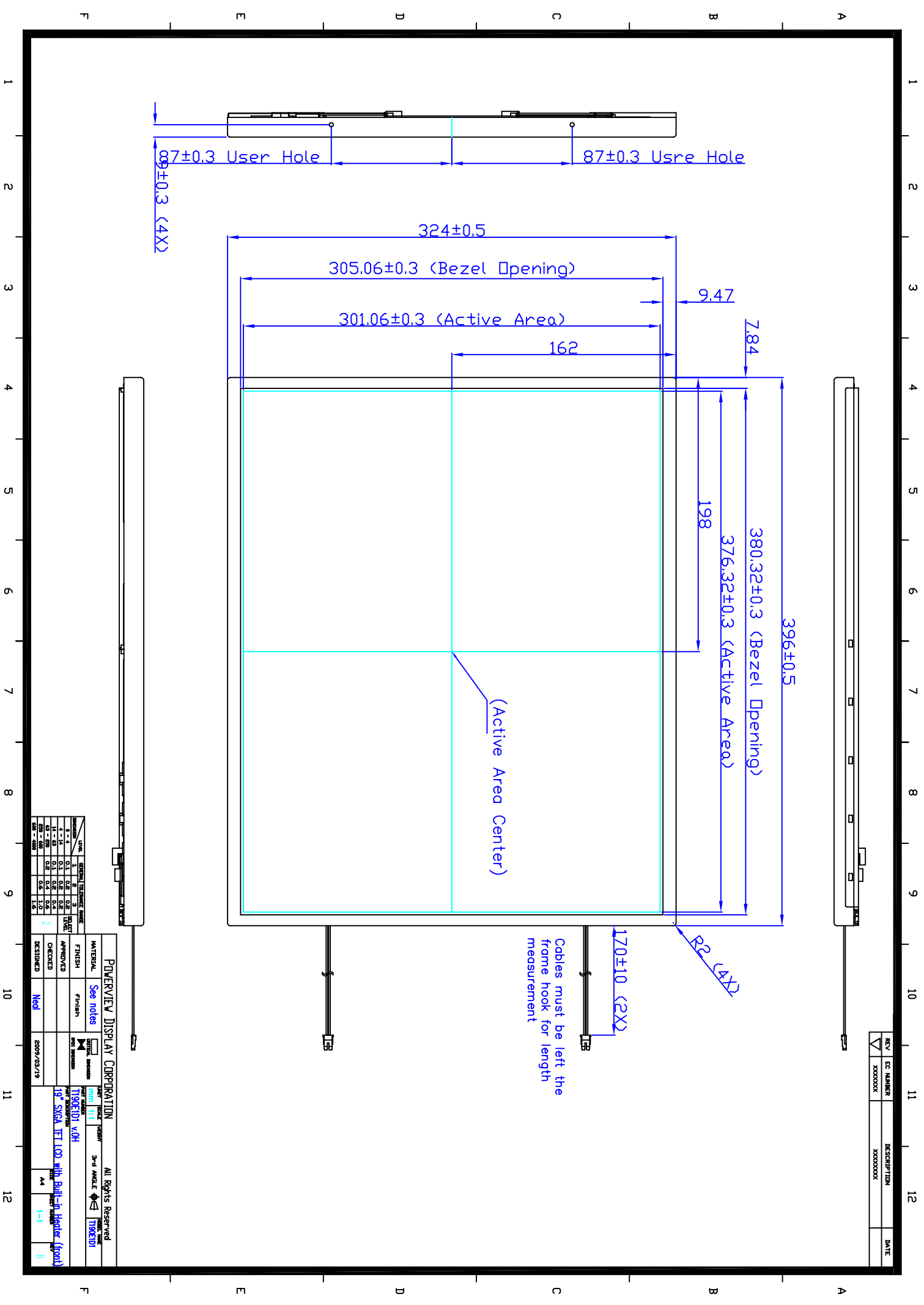

REV	EC NUMBER	DESCRIPTION	DATE
1	X00000X	X00000X	

Cables must be left the frame hook for length measurement

UNIT	GENERAL TOLERANCE RANGE	UNIT	GENERAL TOLERANCE RANGE
mm	±0.1	mm	±0.1
mm	±0.2	mm	±0.2
mm	±0.3	mm	±0.3
mm	±0.5	mm	±0.5
mm	±1.0	mm	±1.0
mm	±1.5	mm	±1.5

POVERVIEW DISPLAY CORPORATION		All Rights Reserved	
MATERIAL		FINISH	
See notes		Finish	
DATE		REV	
2009/03/19		1-1	
19" SXGA TFT LCD with built-in Header (front)		1-1	
CHECKED		APPROVED	
Niel		2	
DESIGNED		REVISION	
		A4	
		B	

REV	EC NUMBER	DESCRIPTION	DATE
1	X00000X	X00000X	

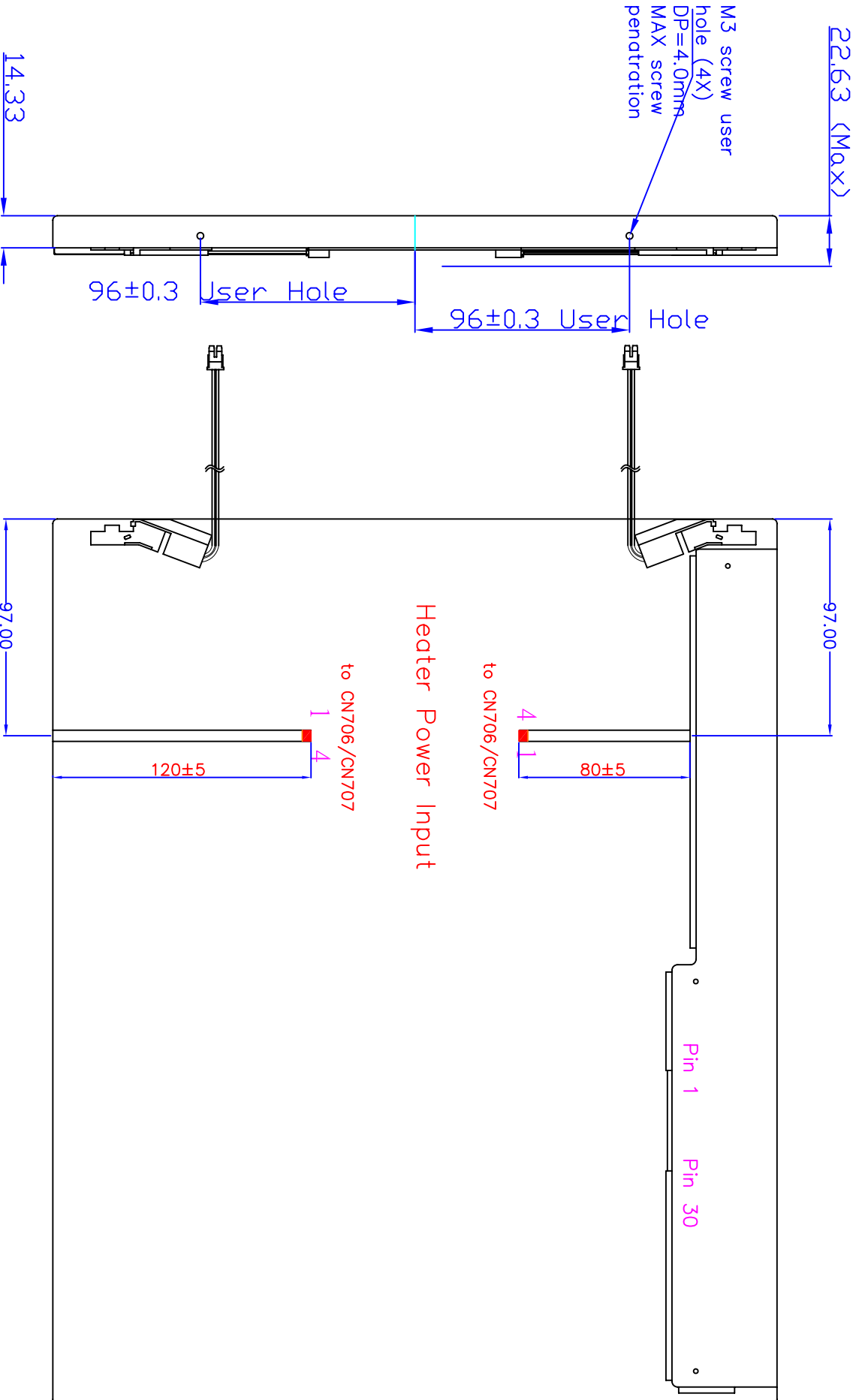

SIZE	GENERAL TOLERANCE RANGE	FINISH
3 - 4	0.1	0.2
5 - 14	0.1	0.2
15 - 25	0.2	0.3
26 - 50	0.3	0.4
51 - 100	0.4	0.5
101 - 200	0.5	0.6
201 - 400	0.6	0.7
401 - 600	0.7	0.8
601 - 1000	0.8	0.9

MATERIAL		FINISH		APPROVED		CHECKED		DESIGNED	
See notes		Finish						Ncd	
POVERVIEW DISPLAY CORPORATION		TIGERD1 X0H		2009/03/19					

POVERVIEW DISPLAY CORPORATION
 All Rights Reserved
 3rd ANGLE
 TIGERD1 X0H

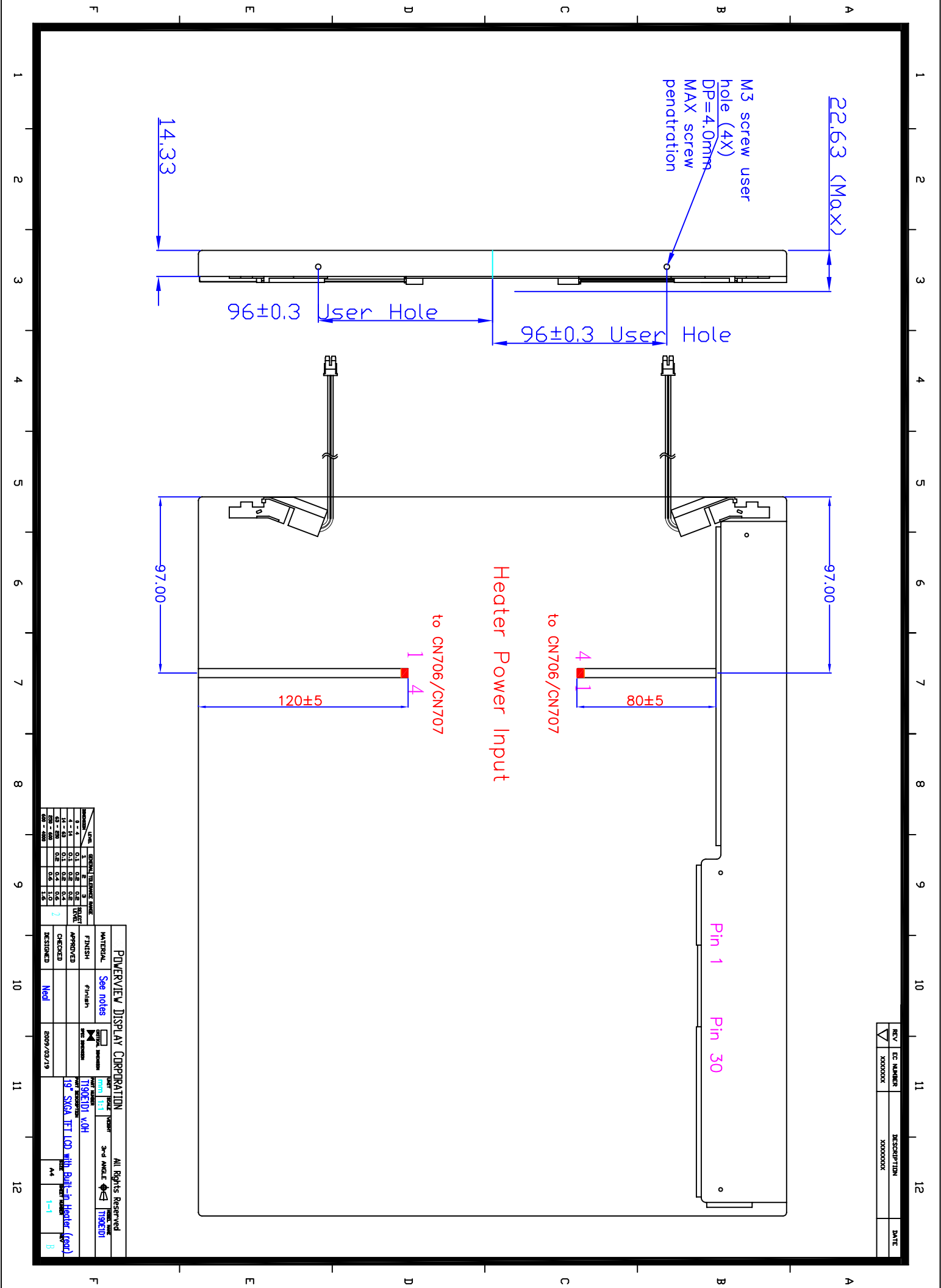

REV	EC NUMBER	DESCRIPTION	DATE
1	X00000X	X00000X	

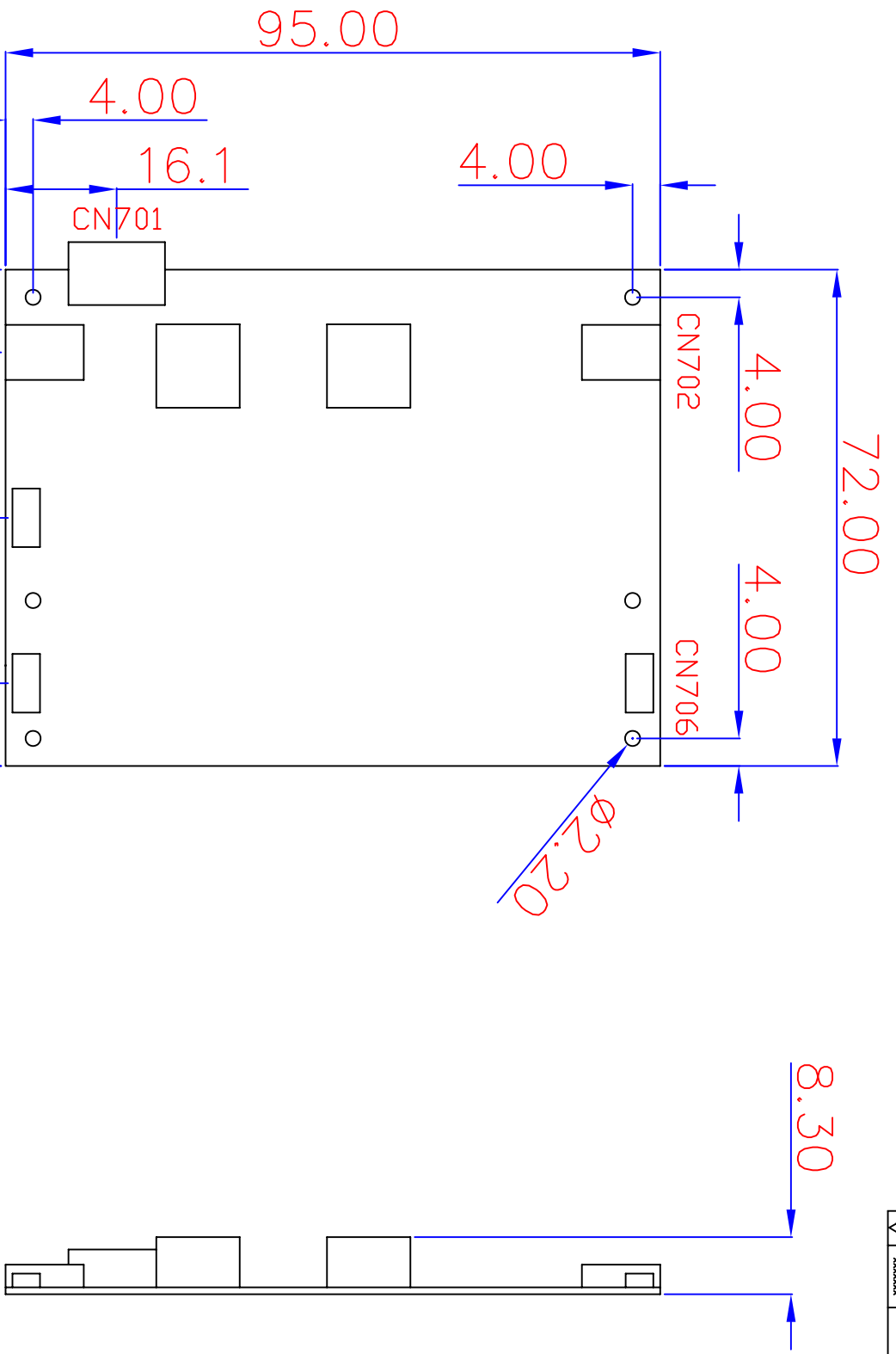

UNIT	GENERAL TOLERANCE RANGE	FINISH
1 - 4	0.1	0.2
5 - 14	0.1	0.2
15 - 24	0.1	0.2
25 - 34	0.1	0.2
35 - 44	0.1	0.2
45 - 54	0.1	0.2
55 - 64	0.1	0.2
65 - 74	0.1	0.2
75 - 84	0.1	0.2
85 - 94	0.1	0.2
95 - 104	0.1	0.2
105 - 114	0.1	0.2
115 - 124	0.1	0.2
125 - 134	0.1	0.2
135 - 144	0.1	0.2
145 - 154	0.1	0.2
155 - 164	0.1	0.2
165 - 174	0.1	0.2
175 - 184	0.1	0.2
185 - 194	0.1	0.2
195 - 204	0.1	0.2
205 - 214	0.1	0.2
215 - 224	0.1	0.2
225 - 234	0.1	0.2
235 - 244	0.1	0.2
245 - 254	0.1	0.2
255 - 264	0.1	0.2
265 - 274	0.1	0.2
275 - 284	0.1	0.2
285 - 294	0.1	0.2
295 - 304	0.1	0.2
305 - 314	0.1	0.2
315 - 324	0.1	0.2
325 - 334	0.1	0.2
335 - 344	0.1	0.2
345 - 354	0.1	0.2
355 - 364	0.1	0.2
365 - 374	0.1	0.2
375 - 384	0.1	0.2
385 - 394	0.1	0.2
395 - 404	0.1	0.2

MATERIAL	FINISH	APPROVED	CHECKED	DESIGNED
See notes	Finish			

POVERVIEW DISPLAY CORPORATION
 ALL RIGHTS RESERVED
 DATE: 2009/03/19
 19" SXGA LED Driver & Heater
 A4
 1-1
 B



8.0 Labeling, Packaging & Others

* Labeling

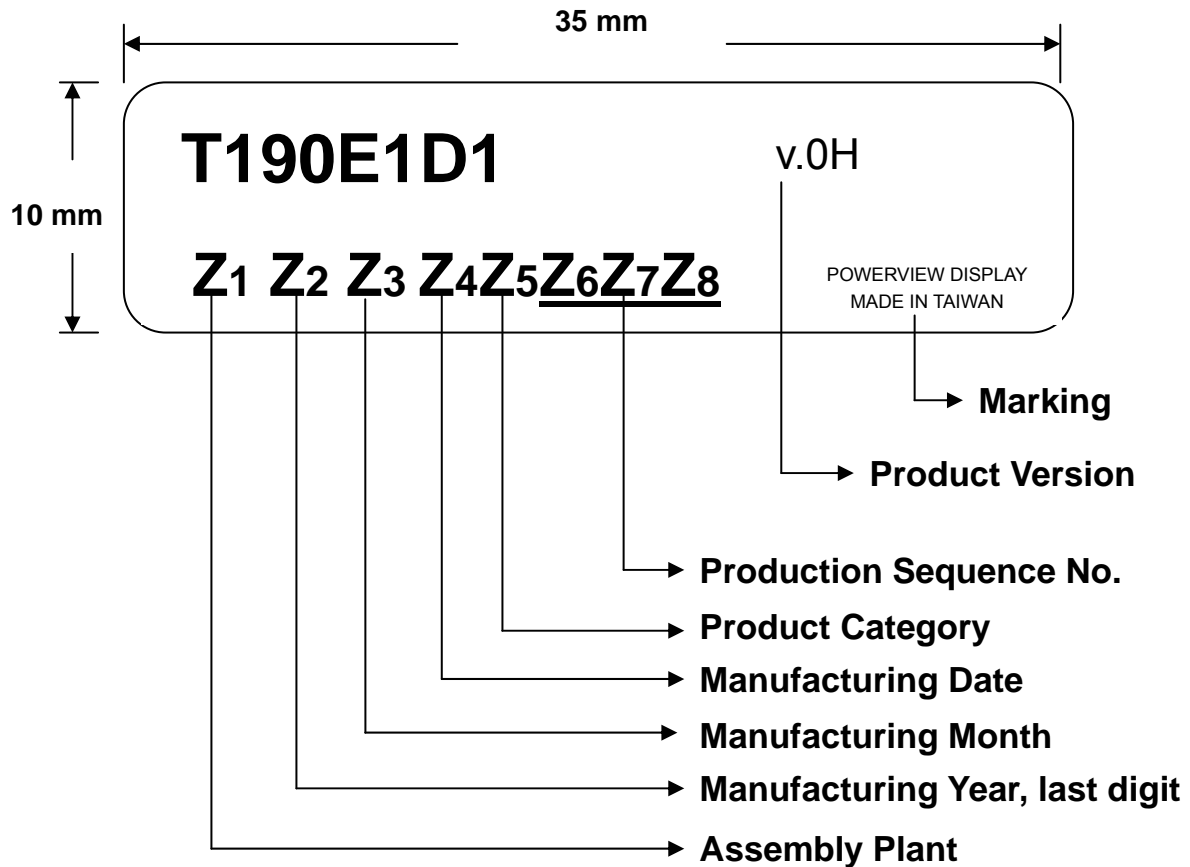



*** Packaging**

- TBD



9.0 General Notice

9.1 Reliability Test Items (Note 2)

No.	Test Items	Conditions	Remark
1	High Temperature Storage	Ta= + 70°C 240 Hrs	
2	Low Temperature Storage	Ta= - 30°C 240 Hrs	
3	High Temperature Operation	Ta= + 60°C 240 Hrs	
4	Low Temperature Operation	Ta= - 30°C 240 Hrs	
5	High Temperature and High Humidity	Tp= 40°C, 90%RH 240 Hrs	operation
6	Heat Shock	-30~60°C/200 cycles 1Hr/cycle	Non-operation
7	Electrostatic discharge	10KV, 150pF(330Ω), 1 second, 9 positions on the panel, 10 times each place.	Non-operation
8	Vibration	Frequency range : 10~500~10Hz Stoke : 1.3mm Sweep : 1G Cycle : 30 minutes 1 hours for each direction of X,Y,Z	
9	Mechanical Shock	50G, 11ms, ±X±Y±Z once for each direction	
10	Vibration (with carton)	Random vibration : 0.015G ² /Hz from 5~200Hz -6dB/octave from 200~500Hz	IEC 68-34
11	Drop (with carton)	Height : 60 cm 1 corner, 3 edges, 6 surfaces	JIS Z0202

Note1: Ta: Ambient temperature.

Note 2: In the standard conditions, there is not display function NG issue occurred. All the cosmetic specification is judged before the reliability stress.



9.2 Storage, Operation & Others

- (a) Do not leave the panel in high temperature, and high humidity for a long time.
It is highly recommended to store the module with temperature from 0 to 35°C and relative humidity of less than 70%.
- (b) Do not store the TFT-LCD module in direct sunlight.
- (c) The module shall be stored in a dark place. It is prohibited to apply sunlight or fluorescent light during the store.
- (d) Do not connect, disconnect the module in the "Power On" condition.
- (e) Power supply should always be turned on/off by the item 3.2 "Electrical Absolute Ratings"
- (f) The liquid-crystal is deteriorated by ultraviolet rays. Do not leave it in direct sunlight and strong ultraviolet rays for many hours.
- (g) Avoid condensation of water. It may result in improper operation or disconnection of electrode.
- (h) Do not exceed the absolute maximum rating value. (the supply voltage variation, input voltage variation, variation in part contents and environmental temperature, and so on) Otherwise the panel may be damaged.
- (i) If the panel displays the same pattern continuously for a long period of time, it can be the situation when the image "Sticks" to the screen.
- (j) This panel has its circuitry FPC on the bottom side and should be handled carefully in order not to be stressed.