



# ***TFT-LCD MONITOR***

## ***Product Information***

**MODEL NO. : T150X1D1 v.1**

**Date : 2007.7.22 revision 2.2**

**Prepared by :** Jackey Chen

*Jackey Chen, Senior Engineer, Product Development Div.*

**Approved by :** Kelvin Hsieh

*Kelvin Hsieh, Senior Engineer, Product Development Div.*

**Note :** This TFT LCD Monitor is distributed by:



Display Solution AG  
Talhofstraße 32a  
D-82205 Gilching  
GERMANY  
Fon +49 (0)8105 / 73 403 - 0  
Fax +49 (0)8105 / 73 403 - 79  
E-Mail: info@display-solution.com  
Internet: www.display-solution.com

This product specification is subject to change without any notice.



## Records of Revision

Date	Rev. No.	Summary	Page
2006.8.25	1.0(temp.)	First Release	1
2007.2.16	2.0	4.0 Optical Characteristics/Contrast Ratio revised→ 500	8
		4.0 Optical Characteristics/Luminance $V_{DIM=MAX}$ revised to $V_{EN}=3.3V$	8
		4.0 Optical Characteristics/Viewing Angle revised to 130/120	8
		4.0 Note(1) $V_{DIM} = 1.5V_{max}$ revised to $V_{EN} = 3.3V$ (Mode 1)	8
		5.2.1 Note Note(1) & Note(2) added and revised	10
		5.3.2 Mode 1/Note 1/ +0.8~+1.3V(Max. Brightness) revised → +0.8~+1.4V(Max. Brightness)	12
		5.3.2 Mode 2/Note 1/ Enable $V_{EN}>1.6V$ revised→ $V_{EN}>1.8V$	12
		5.3.4 Color Data Reference/ 6 bit data signals revised→ 6 bit data signals + FRC (frame rate control)	12
		5.3.4 revised→ 5.3.3	12
		2007.4.12	2.1
5.3.2 Mode 3 newly added	12		
2007.7.22	2.2	Viewing Angle → wide viewing angle(130° /110° )	5
		2.3.2 Mechanical Dimensions Weight → 1200 ± 50g	6
		Temperature Range Updated Tst -40 → -30 Top -30 → -20	6
		5.2.2 Backlight Unit & LED Driver Data Table renewed	11
		5.3.1 Signal Input Interface Connector Type Revised JAE changed to Hirose	11



<b>Contents</b>		<b>Page</b>
<b>1.0 Handling Precautions</b>	-----	<b>4</b>
<b>2.0 General Description</b>	-----	<b>5</b>
2.1 General Application	----- 5	
2.2 Main Features	----- 5	
2.3 General Information	----- 5	
2.3.1 Display Characteristics	----- 5	
2.3.2 Mechanical Dimensions	----- 6	
<b>3.0 Absolute Maximum Ratings</b>	-----	<b>6</b>
3.1 Absolute Ratings of Environment Requirement	----- 6	
3.2 Electrical Absolute Ratings	----- 7	
3.2.1 TFT-LCD Module	----- 7	
3.2.2 Backlight Module(LED)	----- 7	
<b>4.0 Optical Characteristics</b>	-----	<b>8</b>
<b>5.0 Electrical Characteristics</b>	-----	<b>10</b>
5.1 AC Timing Characteristics	----- 10	
5.2 DC Characteristics	----- 10	
5.2.1 TFT-LCD Module	----- 10	
5.2.2 Backlight Unit & LED Driver	----- 11	
5.3 Input Terminal Pin Assignment	----- 11	
5.3.1 Signal Input Interface	----- 11	
5.3.2 LED Driver Unit	----- 12	
5.3.3 Color Data Reference	----- 13	
5.4 Input Timing Chart	----- 15	
<b>6.0 Pixel Format Image</b>	-----	<b>16</b>
<b>7.0 Display Outline Dimensions</b>	-----	<b>16</b>
<b>8.0 Labeling, Packaging &amp; Others</b>	-----	<b>19</b>
<b>9.0 General Notices</b>	-----	<b>21</b>
9.1 Reliability Test Item	----- 21	
9.2 Storage, Operation & Others	----- 22	



## 1.0 Handling Precaution

- 1.) Handle with care. Pay attention not to press or scratch the surface of the monitor, especially the polarizer. Do not twist or bend the monitor. It may cause un-recoverable damage.
- 2.) Do not drop or bump the monitor since this monitor contains fragile glass components. Breakage of this monitor might cause leakage of the liquid crystal sealed inside the glasses. Do not touch the liquid crystal liquid in case of leakage. **Flush with massive water immediately in case of contact with your skin by liquid crystal fluid and call for doctor for immediate medical treatment.**
- 3.) Be sure to turn off power supply while plug or un-plug the power input connector.
- 4.) Clean up the polarizer only with soft solvent if necessary. The desirable cleaners are water, IPA(Isopropyl Alcohol) or Hexane. Do not use Ketone type materials (ex. Acetone), Ethyl alcohol, toluene, Ethyl acid or Methyl chloride. It will permanently damage the polarizer due to chemical reaction.
- 5.) Wipe off fluid drop immediately to prevent from possible discoloration or spots on the polarizer.
- 6.) Do not twist nor bend the monitor structure, even momentarily. Bending or twisting torque may likely damage the internal components of the monitor.
- 7.) The cold cathode fluorescent lamp in LCD contains small amount of mercury (Hg). Please refer to the design specification for application and the local regulations and environmental laws for disposal purpose.
- 8.) Protect the monitor from static environment to prevent from damage to the CMOS gate array IC.



## 2.0 General Description

T150X1D1 v.1 is a 15 inch (4:3 aspect ratio) color active matrix TFT LCD monitor with excellent display performance driven by a pure **DIGITAL** LVDS interface assembled in a compact and slim **LED backlight** unit. This LCD supports 1024(H) x RGB x 768(V) stripe color pixel format and 16,194,277 colors (RGB 8 bits data) with vivid color image. Its outstanding performances with wide operation temperature range, **-20 ~ +70°C**, sunlight readable brightness, **800 nits(typ.)**, wide viewing angle(130°/110°) and high contrast ratio 500:1, make this monitor very suitable for applications under severe environments or outdoor use.

### 2.1 General Applications

- Display terminal for applications of Car Navigation, Industrial, Medical, Gaming, HMI, Amusement, Advertisement or more

### 2.2 Main Features

- 4:3 1024 x RGB x 768 Display Aspect Ratio
- LED Backlight
- Sunlight Readable Brightness
- High Contrast Ratio
- Wide Operational Temperature Range
- High Color Saturation
- Fast Response Time
- Pure Digital LVDS (Low Voltage Differential Signaling) Interface
- DE (Data Enable) Mode
- RoHS Compliance

### 2.3 General Information

#### 2.3.1 Display Characteristics

Item	Specification	Unit	Note
Display Area (HxV)	304.1 x 228.1	mm	15.0" Diagonal
Driver Element	a-Si TFT Active Matrix	-	-
Number of Pixels (HxV)	1024 x RGB x 768	pixel	Std. 4:3
Pixel Arrangement	R.G.B Vertical Stripe	-	-
Dot Pitch (HxV)	0.099 x 0.297	mm	Dot
Viewing Angle (H/V)	160/160	degree	6 o'clock
Signal Interface	LVDS, Digital RGB 24 bits		16.7M colors



Display Mode	Normally White	-	-
Surface Treatment	3H Hard Coating, 25% Haze AG	-	-

**2.3.2 Mechanical Dimensions**

Item		Min.	Typ.	Max.	Unit	Note
Dimension	Horizontal		326.5		mm	±0.5 mm
	Vertical		253.5			±0.5 mm
	Depth	-	14.4			+0.5 mm
Weight		-	-	1200	g	±50 g

**3.0 Absolute Maximum Ratings**

**3.1 Absolute Ratings of Environment Requirement**

Item	Symbol	Min.	Max.	Unit	Note
Storage Temperature	Tstg	-30	+ 80	°C	
Operation Temperature (Ambient Temperature)	Top	-20	+ 70	°C	

**Note (1)** Temperature and relative humidity range are shown in the figure below.

95% RH Max. ( $40^{\circ}\text{C} > T_a$ )

Maximum wet – bulb temperature at  $39^{\circ}\text{C}$  or less. ( $T_a > 40^{\circ}\text{C}$ ) No condensation.

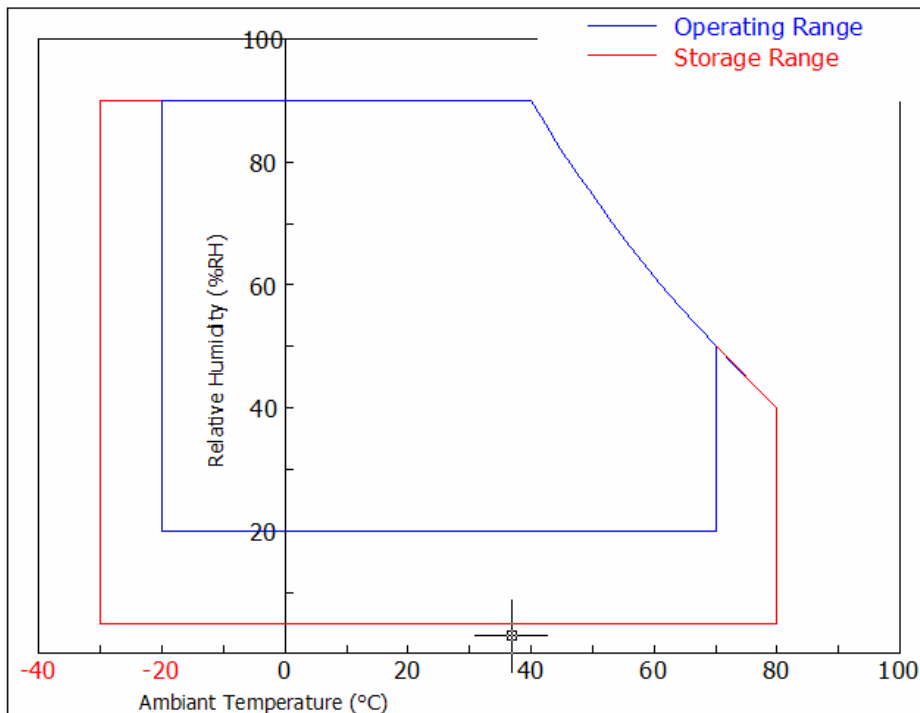



### 3.2 Electrical Absolute Ratings

#### 3.2.1 TFT-LCD Module

(Ta=25±2°C), Vgg=GND=0V)

Item	SYMBOL	Min.	Max.	UNIT	NOTE
Power Supply Voltage	V <sub>DD</sub>	-0.3	4.0	V	(1),(2)
Logic Input Voltage	V <sub>i1</sub>	-0.3	2.7	V	(1),(2)

#### 3.2.2 Backlight Module(LED)

Item	SYMBOL	MIN	MAX	UNIT	NOTE
Input DC Voltage	V <sub>BL</sub>	-	15	V	(1),(2)

**Note (1)** Within operating temperature

**Note (2)** Permanent damage to the device may occur if maximum values are exceeded.

Functional operation should be restricted to the conditions described under normal operating conditions.



## 4.0 Optical Characteristics

The following items are measured under stable conditions in a dark room or equivalent state.

\* Measuring Equipment: BM-5A, PR-650

( $V_{DD}=3.3V$ ,  $f_V=60Hz$ ,  $f_H=15.734KHz$ ,  $T_a=25\pm 2^\circ C$ )

Item		Symbol	Condition	Min.	Typ.	Max.	Unit	Note
Contrast Ratio		CR	At optimized Viewing Angle	-	500	-	-	(1)(2) (4)
Response Time at 25°C	Rising	$T_R$	$\theta=0^\circ$	-	8	13	ms	(3)
	Falling	$T_F$		-	17	22		
Luminance(center)		$Y_L$	$V_{EN}=3.3V$		800	-	cd/m <sup>2</sup>	(1)(2) (6)
Color Chromaticity (CIE 1931)	White	$W_X$	$\theta=0^\circ$		TBD		-	(2)(6)
		$W_Y$	$\theta=0^\circ$		TBD		-	
Viewing Angle	Hor.	$\theta_L$	CR $\geq$ 10 at center point	-	65	-	Degree	(2)(5)
		$\theta_R$		-	65	-		
	Ver.	$\theta_H$		-	65	-		
		$\theta_L$		-	55	-		

**Note (1)** : Ambient temperature =25°C , and , using the Mode 2 of LED control scheme and  $V_{DIM}=0V$  to get the maximum brightness. To be measured in the dark room.

**Note (2)** : To be measured on the center area of panel with a viewing cone of 1° by Topcon Luminance Meter BM-5, after 10 minutes operation.

**Note (3)** : Definition of response time:

The output signals of photo detector are measured when the input signals are changed from “black” to “white”(falling time) and from “white” to “black”(rising time), respectively.

The response time is defined as the time interval between the 10% and 90% of amplitudes. Refer to figure as below.

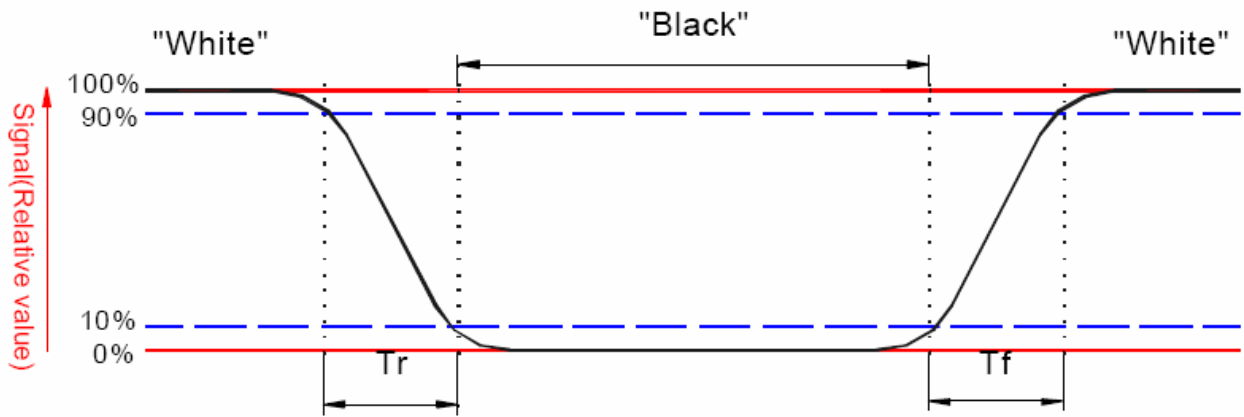

**Note (4)** : Definition of contrast ratio:

Contrast ratio is calculated with the following formula.

$$\text{Contrast ratio (CR)} = \frac{\text{Photo detector output when LCD is at "White" state}}{\text{Photo detector output when LCD is at "Black" state}}$$

**Note (5)** : Definition of viewing angle, Refer to figure as below.

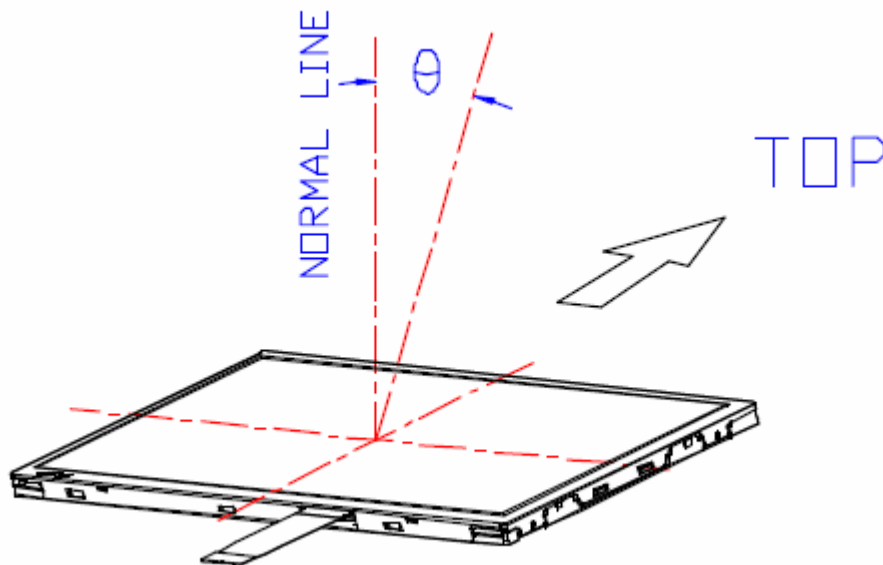

**Note (6)** : Measured at the center area of the panel when all the input terminals of LCD panel are electrically opened.



## 5.0 Electrical Characteristics

### 5.1 AC Timing Characteristics

Signal	Item	Symbol	Min.	Typ.	Max.	Unit	Note
LVDS Clock	Frequency	Fc	57.5	64.9	74.4	MHz	-
	Period	Tc	13.4	15.4	17.3	ns	
Vertical Active Display Term	Frame Rate	Fr	56	60	75	Hz	Tv=Tvd+Tvb
	Total	Tv	774	806	848	Th	-
	Display	Tvd	768	768	768	Th	-
	Blank	Tvb	Tv-Tvd	38	Tv-Tvd	Th	-
Horizontal Active Display Term	Total	Th	1240	1344	1464	Tc	Th=Thd+Thb
	Display	Thd	1024	1024	1024	Tc	-
	Blank	Thb	Th-Thd	320	Th-Thd	Tc	-

Note : (1) Hsync and Vsync input signals should be set to low logic level or ground because this LCD module is operated by "DE only" mode. Otherwise, this module would operate abnormally.

### 5.2 DC Characteristics

#### 5.2.1 TFT-LCD Module

Item	Symbol	Min.	Typ.	Max.	Unit	Note	
Power Supply	V <sub>DD</sub>	3.0	3.3	3.6	V	Note 1	
	I <sub>DD</sub>	White	-	500	-	mA	V <sub>DD</sub> =3.3V
		Black		750	-	mA	
Permissive Input Ripple Voltage	V <sub>RF</sub>	-	-	100	mV <sub>P-P</sub>	V <sub>DD</sub> =3.3V	
LVDS Differential Input Voltage	V <sub>id</sub>	-100		100	mV	Note 2	
LVDS Common Input Voltage	V <sub>ic</sub>		1.2		V		

Note (1) VDD Power-On Condition :

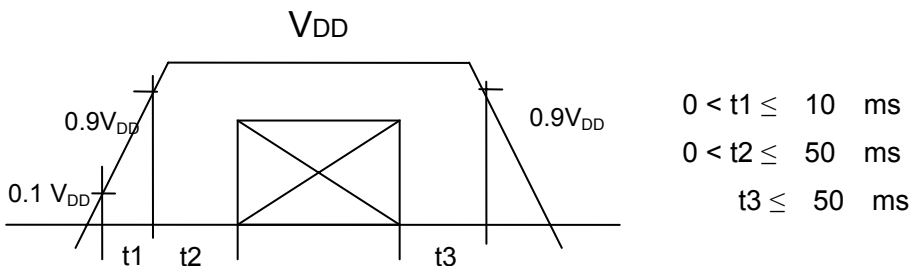

Note (2) CLK, Hsync, Vsync, DE, R0~R7, G0~G7, B0~B7



### 5.2.2 Backlight Unit & LED Driver (LD150X1D1v1)

Item	Symbol	Min.	Typ.	Max.	Unit	Note
Power Supply	$V_{BL}$	10.8	12	13.2	V	
	$I_{BL}$		1.48	1.8	Amp	Note 1

Note 1 :  $V_{BL} = 12V$ , using the Mode 2 of LED control scheme and  $V_{DIM} = 0V$  to get the maximum brightness.

## 5.3 Input Terminal Pin Assignment

### 5.3.1 Signal Input Interface

Hirose Connector: 20 pin 1.25 mm pitch DF14H-20P-1.25H

Mating Connector : Hirose DF14-20S-1.25C

Pin No	Symbol	Description	Remark
1	$V_{CC\_IN}$	Power supply (+3.3V)	-
2	$V_{CC\_IN}$	Power Supply ( +3.3V)	-
3	GND	Ground	-
4	GND	Ground	-
5	RxIN0-	LVDS receiver signal channel 0	R0~R5, G0
6	RxIN0+		
7	GND	Ground	-
8	RxIN1-	LVDS receiver signal channel 1	G1~G5, B0, B1
9	RxIN1+		
10	GND	Ground	-
11	RxIN2-	LVDS receiver signal channel 2	B2~B5, DE, Hsync, Vsync
12	RxIN2+		
13	GND	Ground	-
14	CLKIN-	LVDS receiver signal clock	LVDS Level Colck
15	CLKIN+		
16	GND	Ground	-
17	RxIN3-	LVDS receiver signal channel 3	R6~R7, G6~G7 B6~B7
18	RxIN3+		
19	GND	Ground	-
20	GND	Ground	-



### 5.3.2 LED Driver Unit

Connector : ACES 88290-0601 pitch 2.0mm 6 pins CN

#### Mode 1 :

Matching Connector : ACES 86809-0600 CN

Pin No.	Symbol	Description	Remark
1	V <sub>BL</sub>	Power Supply for LED Driver	
2	V <sub>BL</sub>	Power Supply for LED Driver	
3	EN	LED Enable & Dimming Control Input	Note 1
4	DIM	Connect this pin to GND at this mode	Note 2
5	GND	Ground Pin for LED Driver	
6	GND	Ground Pin for LED Driver	

Note 1 : The “Enable & Dimming Control” of the LED driver shares the same pinning.

The LED backlight will turn on when the input voltage of this pin exceeds +0.6V.

The LED current/brightness will be adjustable by applying an analog voltage between +0.8 ~ +1.4V(Max. Brightness).

Note 2: The “DIM” pin should be connected to GND in order to get the full brightness.

#### Mode 2:

Pin No.	Symbol	Description	Remark
1	V <sub>BL</sub>	Power Supply for LED Driver	
2	V <sub>BL</sub>	Power Supply for LED Driver	
3	EN	LED Enable Control Input	Note 1
4	DIM	Dimming Control Input	Note 2
5	GND	Ground Pin for LED Driver	
6	GND	Ground Pin for LED Driver	

Note 1 : Disable V<sub>EN</sub><0.6 V, Enable V<sub>EN</sub>>1.8 V

Note 2 : Max Brightness V<sub>DIM</sub> : 0V, Min Brightness V<sub>DIM</sub> : 2.2V ( ≈ 0 Nit )

#### Mode 3:

Pin No.	Symbol	Description	Remark
1	V <sub>BL</sub>	Power Supply for LED Driver	
2	V <sub>BL</sub>	Power Supply for LED Driver	
3	EN	PWM Control Pulse Input	Note 1, 2
4	DIM	Connect this pin to GND at this mode	Note 3
5	GND	Ground Pin for LED Driver	
6	GND	Ground Pin for LED Driver	

Note 1: Valley of PWM Pulse V<sub>PWM</sub><0.6 V, Peak of PWM Pulse V<sub>PWM</sub> >1.8 V

Note 2: The frequency of each completed PWM cycle: 100~300 Hz



Note 3: The “DIM” pin should be connected to GND in order to get the full brightness.

### 5.3.3 Color Data Reference

The below table is about input signal, Basic display colors and gray scale of each color.

0 : Low Level Voltage      1 : High Level Voltage

Each basic color can be displayed in 256 gray scales from 6 bit data signals with FRC(Frame Rate Control). With the combination of total 24 bit data signals, the 1.677M color display can be achieved on the screen.

- Please refer to the next page



	Colors & Gray Scale	Data Signal																											
		Gray Scale	R0	R1	R2	R3	R4	R5	R6	R7	G0	G1	G2	G3	G4	G5	G6	G7	B0	B1	B2	B3	B4	B5	B6	B7			
Basic Color	Black	-	0	0	0	0	0	0	0	0	0	0	0	0	0	0	0	0	0	0	0	0	0	0	0	0	0		
	Blue	-	0	0	0	0	0	0	0	0	0	0	0	0	0	0	0	0	1	1	1	1	1	1	1	1	1		
	Green	-	0	0	0	0	0	0	0	0	1	1	1	1	1	1	1	1	0	0	0	0	0	0	0	0	0		
	Cyan	-	0	0	0	0	0	0	0	0	1	1	1	1	1	1	1	1	1	1	1	1	1	1	1	1	1		
	Red	-	1	1	1	1	1	1	1	1	0	0	0	0	0	0	0	0	0	0	0	0	0	0	0	0	0		
	Magenta	-	1	1	1	1	1	1	1	1	0	0	0	0	0	0	0	0	1	1	1	1	1	1	1	1	1		
	Yellow	-	1	1	1	1	1	1	1	1	1	1	1	1	1	1	1	1	0	0	0	0	0	0	0	0	0		
	White	-	1	1	1	1	1	1	1	1	1	1	1	1	1	1	1	1	1	1	1	1	1	1	1	1	1		
Gray Scale of Red	Black	GS0	0	0	0	0	0	0	0	0	0	0	0	0	0	0	0	0	0	0	0	0	0	0	0	0	0		
	↑	GS1	1	0	0	0	0	0	0	0	0	0	0	0	0	0	0	0	0	0	0	0	0	0	0	0	0		
	Darker	GS2	0	1	0	0	0	0	0	0	0	0	0	0	0	0	0	0	0	0	0	0	0	0	0	0	0		
	↑	↓					↓							↓								↓							
	↓	↓					↓							↓								↓							
	Brighter	GS253	1	0	1	1	1	1	1	1	0	0	0	0	0	0	0	0	0	0	0	0	0	0	0	0	0		
	↓	GS254	0	1	1	1	1	1	1	1	0	0	0	0	0	0	0	0	0	0	0	0	0	0	0	0	0		
	Red	GS255	1	1	1	1	1	1	1	1	0	0	0	0	0	0	0	0	0	0	0	0	0	0	0	0	0		
Gray Scale of Green	Black	GS0	0	0	0	0	0	0	0	0	0	0	0	0	0	0	0	0	0	0	0	0	0	0	0	0	0		
	↑	GS1	0	0	0	0	0	0	0	0	1	0	0	0	0	0	0	0	0	0	0	0	0	0	0	0	0		
	Darker	GS2	0	0	0	0	0	0	0	0	0	1	0	0	0	0	0	0	0	0	0	0	0	0	0	0	0		
	↑	↓					↓							↓								↓							
	↓	↓					↓							↓								↓							
	Brighter	GS253	0	0	0	0	0	0	0	0	1	0	1	1	1	1	1	1	0	0	0	0	0	0	0	0	0		
	↓	GS254	0	0	0	0	0	0	0	0	0	1	1	1	1	1	1	1	0	0	0	0	0	0	0	0	0		
	Green	GS255	0	0	0	0	0	0	0	0	1	1	1	1	1	1	1	1	0	0	0	0	0	0	0	0	0		
Gray Scale of Blue	Black	GS0	0	0	0	0	0	0	0	0	0	0	0	0	0	0	0	0	0	0	0	0	0	0	0	0	0		
	↑	GS1	0	0	0	0	0	0	0	0	0	0	0	0	0	0	0	0	1	0	0	0	0	0	0	0	0		
	Darker	GS2	0	0	0	0	0	0	0	0	0	0	0	0	0	0	0	0	0	1	0	0	0	0	0	0	0		
	↑	↓					↓							↓								↓							
	↓	↓					↓							↓								↓							
	Brighter	GS253	0	0	0	0	0	0	0	0	0	0	0	0	0	0	0	0	1	0	1	1	1	1	1	1	1		
	↓	GS254	0	0	0	0	0	0	0	0	0	0	0	0	0	0	0	0	0	1	1	1	1	1	1	1	1		
	Blue	GS255	0	0	0	0	0	0	0	0	0	0	0	0	0	0	0	0	1	1	1	1	1	1	1	1	1		

This specification data sheet is an intellectual property of PowerView Display Corporation. Any copy, reproduction or modification without written permission of PowerView Display Corporation is not allowed.

### 5.4 Input Timing Chart

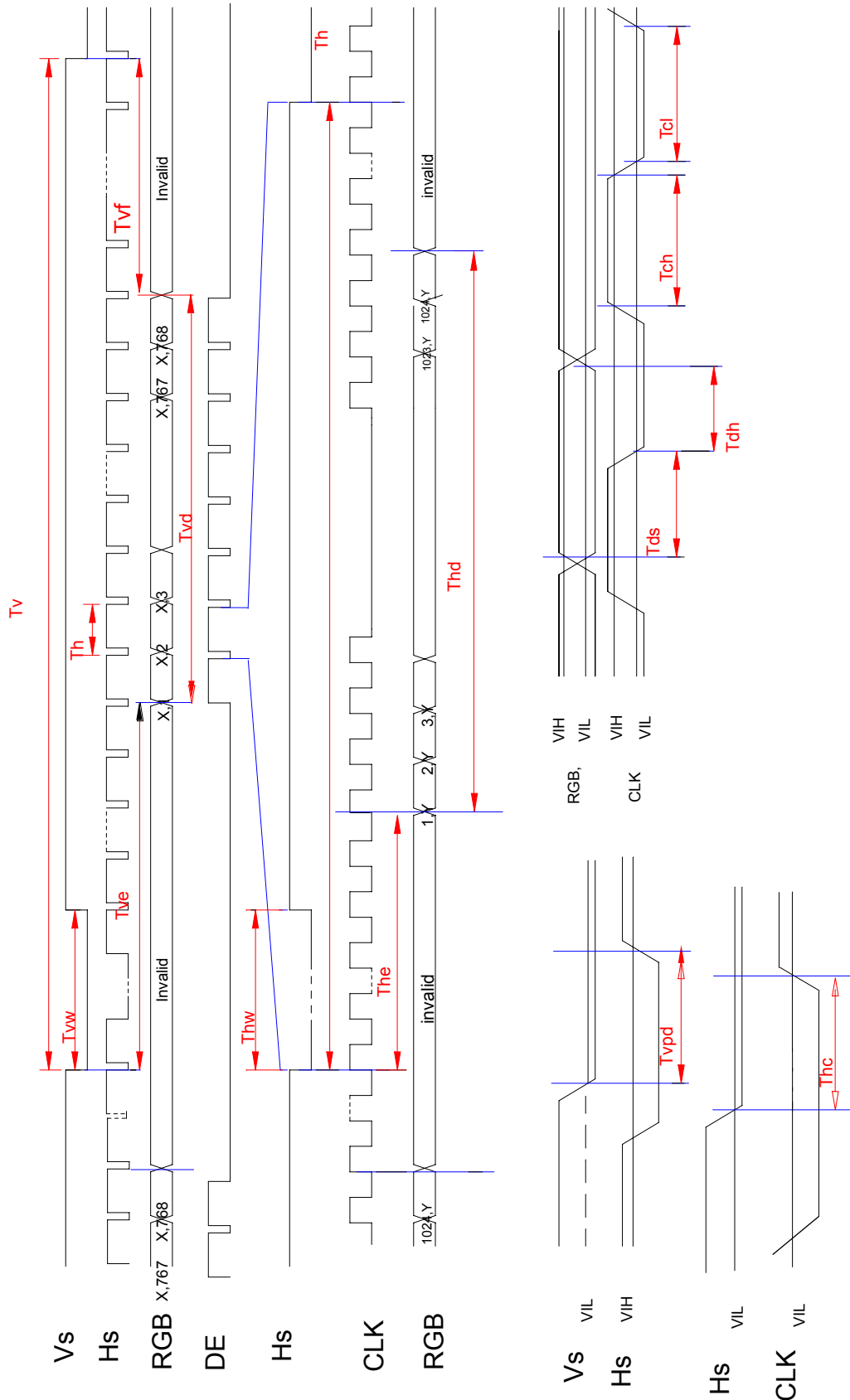



## 6.0 Pixel Format Image

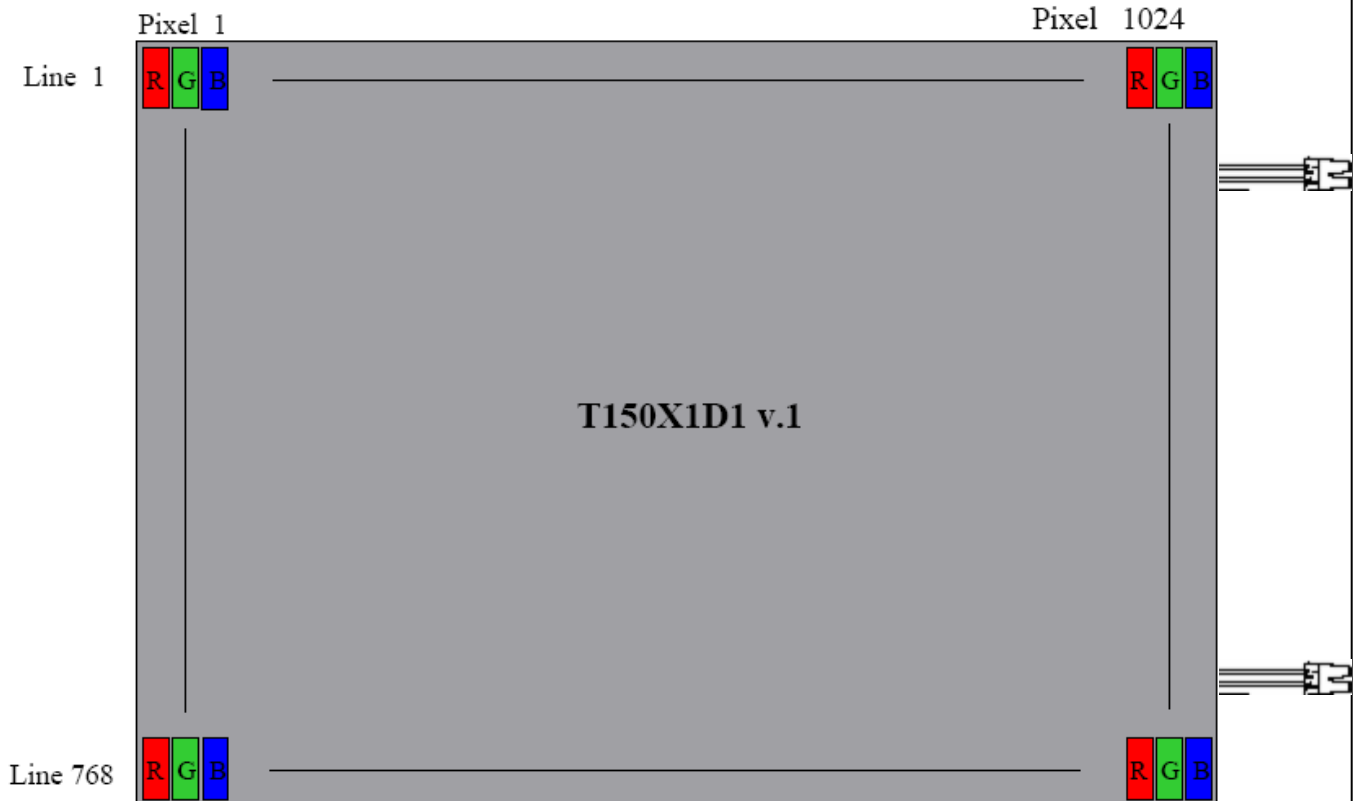

## 7.0 Display Outline Dimensions

### 7.1 Monitor Outline Dimensions

- Please refer to the next page

REV	EC NUMBER	DESCRIPTION	DATE
1	XXXXXXXX	XXXXXXXX	

- NOTES:
1. OUTLINE TOLERANCE 0.5MM
  2. I/F CONNECTOR : DF14H-20P-1.25H (Hirose)
  3. LAMP CONNECTOR : BHSR-02VS-1 (JST)
  4. SIDE MOUNT HOLE ROTATIONAL TORQUE MUST BE MAX 5kgf-cm

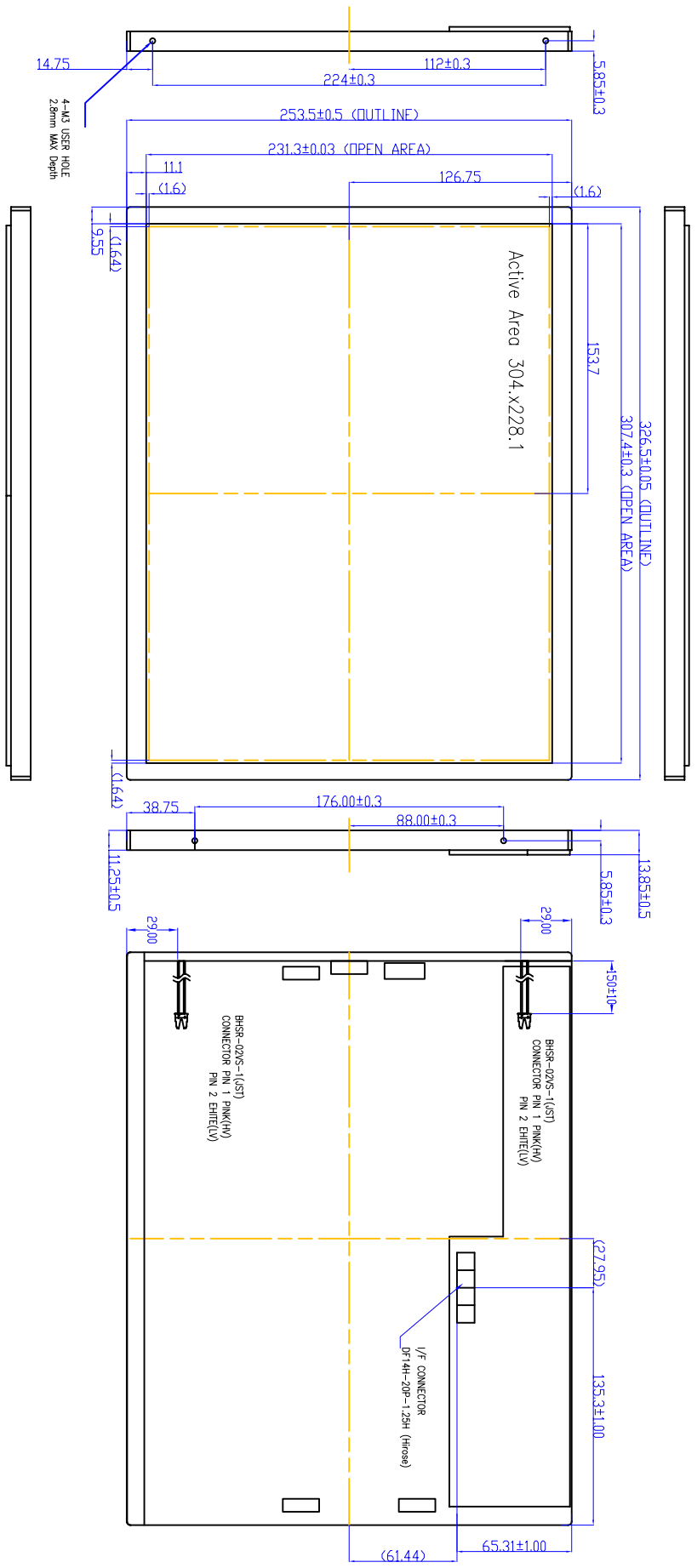

REV	EC NUMBER	DESCRIPTION	DATE
1	XXXXXXXX	XXXXXXXX	

DATE	DESCRIPTION	BY	CHK
07/27/16	DESIGNED	Tim	
08/15/16	CHECKED		
08/15/16	APPROVED		

POVERVIEW DISPLAY CORPORATION  
 All Rights Reserved  
 MATERIAL: See notes  
 FINISH: P-114H  
 APPROVED: 08/15/16  
 CHECKED: Tim  
 DESIGNED: Tim  
 DATE: 08/15/16  
 DRAWING NO: T150X101 v.1  
 T150X101 v.1 High Brightness TFT LCD  
 44 1-1 AI

REV	EC NUMBER	DESCRIPTION	DATE
Δ	XXXXXX	XXXXXX	

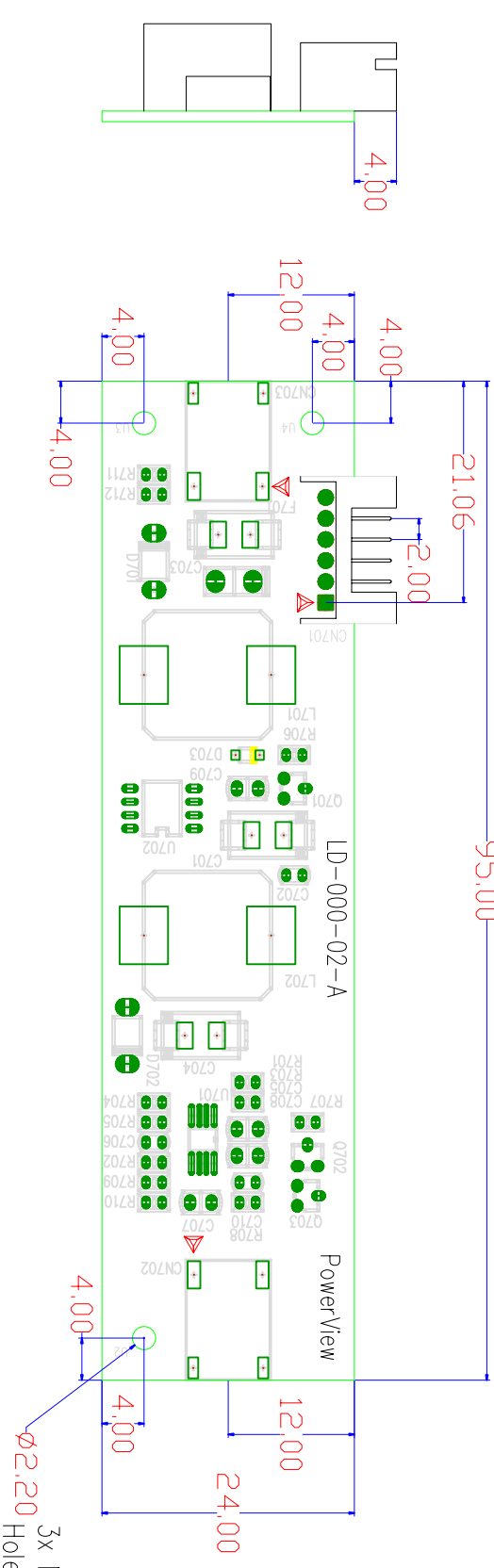

CN701	
SYMBOL	DESCRIPTION
Pin 1 Vin	Power Supply +12V
Pin 2 Vin	Power Supply +12V
Pin 3 ENA	On/Off control (On>+1.8V, Off<+0.8V)
Pin 4 DIM	Linear Dim, 0V(Max.) ~ +1.4V(min.)
Pin 5 GND	Ground
Pin 6 GND	Ground

CN702 / CN703	
SYMBOL	DESCRIPTION
Pin 1 Anode	Anode DC Power Supply for Backlight Unit
Pin 2 Cathod	Cathod DC Power Supply for Backlight Unit

Dimension	1	2	3	4	5	6	7	8	9	10	11	12
0.4 - 0.8	0.1	0.2	0.2	0.2	0.2	0.2	0.2	0.2	0.2	0.2	0.2	0.2
0.8 - 1.6	0.1	0.2	0.2	0.2	0.2	0.2	0.2	0.2	0.2	0.2	0.2	0.2
1.6 - 2.5	0.2	0.4	0.4	0.4	0.4	0.4	0.4	0.4	0.4	0.4	0.4	0.4
2.5 - 4.0	0.2	0.4	0.4	0.4	0.4	0.4	0.4	0.4	0.4	0.4	0.4	0.4
4.0 - 6.3	0.2	0.4	0.4	0.4	0.4	0.4	0.4	0.4	0.4	0.4	0.4	0.4
6.3 - 10.0	0.2	0.4	0.4	0.4	0.4	0.4	0.4	0.4	0.4	0.4	0.4	0.4
10.0 - 20.0	0.2	0.4	0.4	0.4	0.4	0.4	0.4	0.4	0.4	0.4	0.4	0.4
20.0 - 40.0	0.2	0.4	0.4	0.4	0.4	0.4	0.4	0.4	0.4	0.4	0.4	0.4

POVERVIEW DISPLAY CORPORATION		All Rights Reserved	
MATERIAL	See notes	DATE	1/1/21
FINISH	Finish	REV	1/1/21
APPROVED		PART NUMBER	LD150X10V1
CHECKED		REV	1/1/21
DESIGNED	Tim	DATE	2006/10/2
		REV	1-2
		DATE	1/1/21



## 8.0 Labeling, Packaging & Others

### \* Labeling

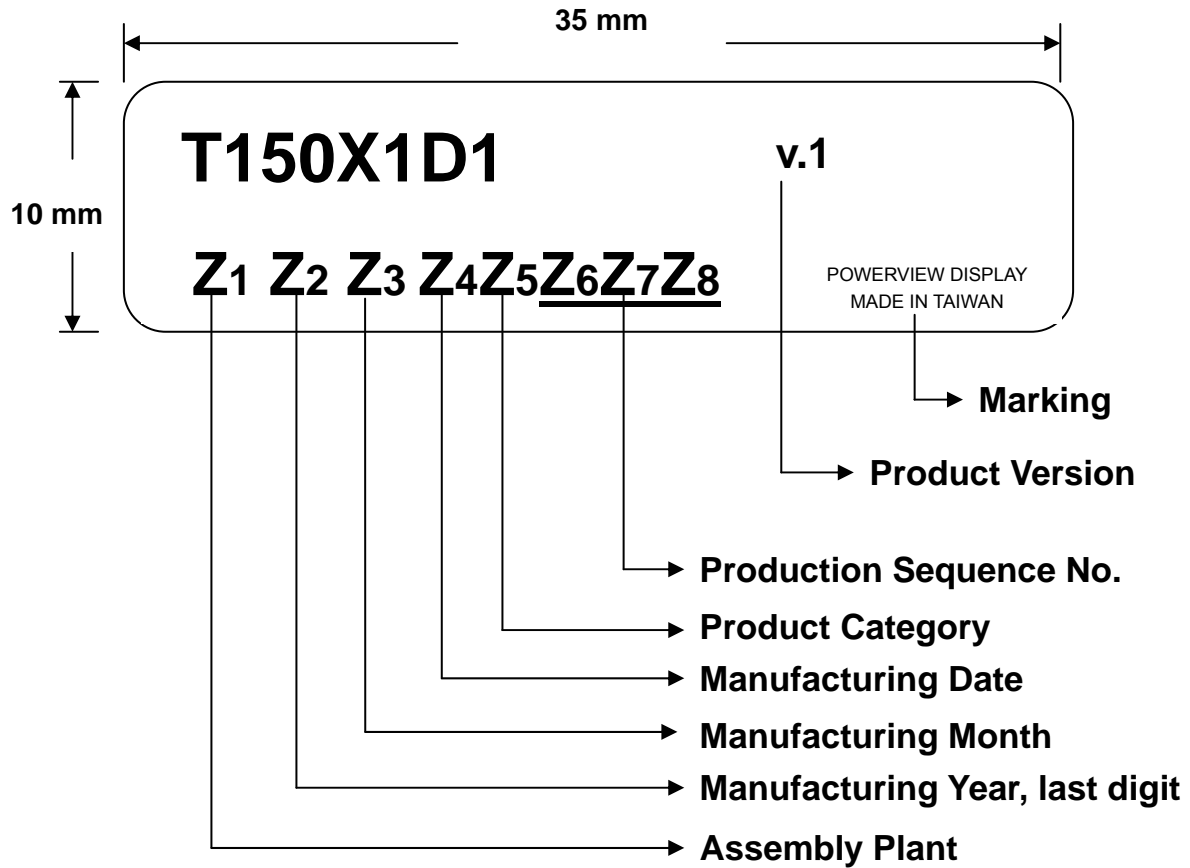

### \* Packaging

- TBD

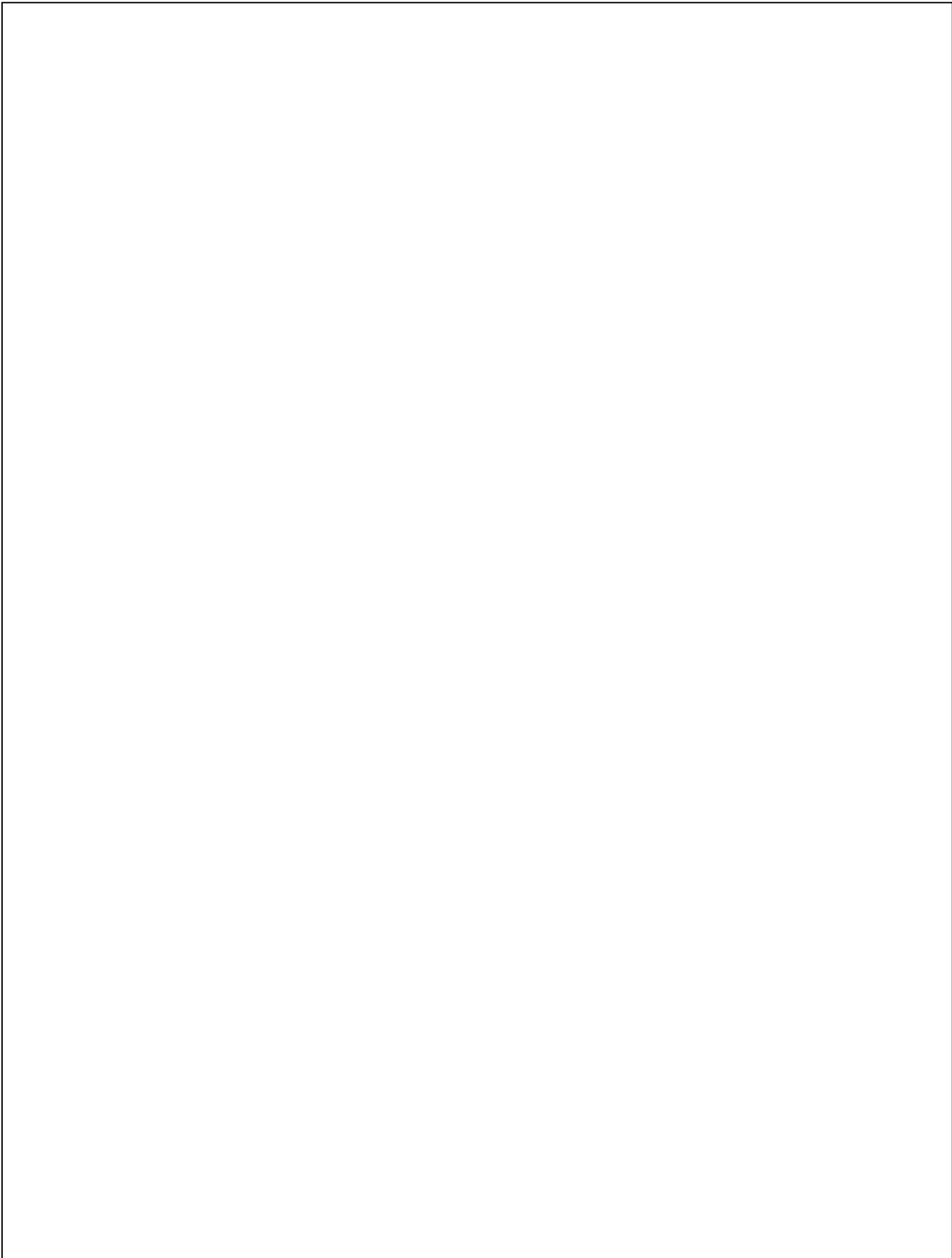



## 9.0 General Notice

### 9.1 Reliability Test Items (Note 2)

No.	Test Items	Conditions	Remark
1	High Temperature Storage	Ta= + 80°C                      240 Hrs	
2	Low Temperature Storage	Ta= - 40°C                      240 Hrs	
3	High Temperature Operation	Ta= + 70°C                      240 Hrs	
4	Low Temperature Operation	Ta= - 30°C                      240 Hrs	
5	High Temperature and High Humidity	Tp= 60°C, 90%RH              240 Hrs	operation
6	Heat Shock	-25~80°C/200 cycles 1Hr/cycle	Non-operation
7	Electrostatic discharge	±200V, 200pF(0Ω), once for each terminal	Non-operation
8	Vibration	Frequency range : 8~33.3 Hz Stoke                      : 1.3mm Sweep                     : 2.9G, 33.3~400Hz Cycle                      : 15 minutes 2 hours for each direction of X,Z 4 hours for Y direction	JIS C7021, A-10 Condition A
9	Mechanical Shock	100G, 6ms, ±X±Y±Z 3 times for each direction	JIS C7021, A-7 Condition C
10	Vibration (with carton)	Random vibration : 0.015G <sup>2</sup> /Hz from 5~200Hz -6dB/octave from 200~500Hz	IEC 68-34
11	Drop (with carton)	Height : 60 cm 1 corner, 3 edges, 6 surfaces	JIS Z0202

Note1: Ta: Ambient temperature.

Note 2: In the standard conditions, there is not display function NG issue occurred. All the cosmetic specification is judged before the reliability stress.



## 9.2 Storage, Operation & Others

- (a) Do not leave the panel in high temperature, and high humidity for a long time.  
It is highly recommended to store the module with temperature from 0 to 35°C and relative humidity of less than 70%.
- (b) Do not store the TFT-LCD module in direct sunlight.
- (c) The module shall be stored in a dark place. It is prohibited to apply sunlight or fluorescent light during the store.
- (d) Do not connect, disconnect the module in the "Power On" condition.
- (e) Power supply should always be turned on/off by the item 3.2 "Electrical Absolute Ratings"
- (f) The liquid-crystal is deteriorated by ultraviolet rays. Do not leave it in direct sunlight and strong ultraviolet rays for many hours.
- (g) Avoid condensation of water. It may result in improper operation or disconnection of electrode.
- (h) Do not exceed the absolute maximum rating value. (the supply voltage variation, input voltage variation, variation in part contents and environmental temperature, and so on) Otherwise the panel may be damaged.
- (i) If the panel displays the same pattern continuously for a long period of time, it can be the situation when the image "Sticks" to the screen.
- (j) This panel has its circuitry FPC on the bottom side and should be handled carefully in order not to be stressed.