



TFT-LCD MONITOR

Product Information

Temporary

MODEL NO. : T104S1D2 v.2

Date : 2008.11.26 Revision 0.1

Prepared by : *Nicholas Shih*

Nicholas Shih, Electrical Engineer, Product Development Div.

Approved by : *Jackey Chien*

Jackey Chien, Director, Product Development Div.

This TFT LCD Monitor is distributed by:



Display Solution AG
Talhofstraße 32a
D-82205 Gilching
GERMANY
Fon +49 (0)8105 / 73 403 - 0
Fax +49 (0)8105 / 73 403 - 79
E-Mail: info@display-solution.com
Internet: www.display-solution.com

This product specification is subject to change without any notice.



Records of Revision

Date	Rev. No.	Summary	Page
2008.11.26	0.1	First Release	



Contents	Page
1.0 Handling Precautions	4
2.0 General Description	5
2.1 General Application	5
2.2 Main Features	5
2.3 General Information	5
2.3.1 Display Characteristics	5
2.3.2 Mechanical Dimensions	6
3.0 Absolute Maximum Ratings	6
3.1 Absolute Ratings of Environment Requirement	6
3.2 Electrical Absolute Ratings	7
3.2.1 TFT-LCD Module	7
3.2.2 Backlight Module(LED)	7
4.0 Optical Characteristics	8
5.0 Electrical Characteristics	10
5.1 AC Timing Characteristics	10
5.2 DC Characteristics	10
5.2.1 TFT-LCD Module	10
5.2.2 Backlight Unit	11
5.3 Input Terminal Pin Assignment	11
5.3.1 Signal Input Interface	11
5.3.2 LED Driver Unit	12
5.4 Color Data Reference	13
5.5 Input Timing Chart	15
6.0 Pixel Format Image	16
7.0 Display Outline Dimensions	16
8.0 Labeling, Packaging & Others	19
9.0 General Notices	21
9.1 Reliability Test Item	21
9.2 Storage, Operation & Others	22



1.0 Handling Precaution

- 1.) Handle with care. Pay attention not to press or scratch the surface of the monitor, especially the polarizer. Do not twist or bend the monitor. It may cause un-recoverable damage.
- 2.) Do not drop or bump the monitor since this monitor contains fragile glass components. Breakage of this monitor might cause leakage of the liquid crystal sealed inside the glasses. Do not touch the liquid crystal liquid in case of leakage. **Flush with massive water immediately in case of contact with your skin by liquid crystal fluid and call for doctor for immediate medical treatment.**
- 3.) Be sure to turn off power supply while plug or un-plug the power input connector.
- 4.) Clean up the polarizer only with soft solvent if necessary. The desirable cleaners are water, IPA(Isopropyl Alcohol) or Hexane. Do not use Ketone type materials (ex. Acetone), Ethyl alcohol, toluene, Ethyl acid or Methyl chloride. It will permanently damage the polarizer due to chemical reaction. 5.) Wipe off fluid drop immediately to prevent from possible discoloration or spots on the polarizer.
- 6.) Do not twist nor bend the monitor structure, even momentarily. Bending or twisting torque may likely damage the internal components of the monitor.
- 7.) Protect the monitor from static environment to prevent from damage to the CMOS gate array IC.



2.0 General Description

T104S1D2 v.2 is a 10.4 inch (4:3 aspect ratio) color active matrix TFT LCD monitor with excellent display performance driven by a pure **DIGITAL LVDS** interface assembled in a compact and **LED backlight** unit. This LCD supports 800(H)xRGBx600(V) stripe color pixel format and 16.7M/262K colors (RGB 24/18 bits data) with vivid color image. Its outstanding performances with wide operation temperature range, **-20 ~ 70°C**, **ultra sunlight readable brightness, 1200 nits(typ.)**, wide viewing angle (140°/120°) and high contrast ratio 500:1, make this monitor very suitable for applications under severe environments or outdoor use.

2.1 General Applications

- Display terminal for applications of Aerospace, Car Navigation, Industrial, Medical, Gaming, HMI, Amusement, Advertisement or more

2.2 Main Features

- 4:3 800 x RGB x 600 Display Aspect Ratio
- LED Backlight with extremely power-saving
- Extremely High Brightness at Low Temperature, 1200 nits @ -20 °C
- Wide Viewing Angle & High Contrast Ratio
- Wide Operational Temperature Range
- Pure Digital LVDS (Low Voltage Differential Signaling) Interface
- DE (Data Enable) Mode
- True Green Product, No Any Mercury Content
- High Safety Product & RoHS Compliance
- Extremely Thin and Light Weight

2.3 General Information

2.3.1 Display Characteristics

Item	Specification	Unit	Note
Display Area (HxV)	211.2 x 158.4	mm	10.4" Diagonal
Driver Element	a-Si TFT Active Matrix	-	-
Number of Pixels (HxV)	800 x RGB x 600	pixel	Std. 4:3
Pixel Arrangement	R.G.B Vertical Stripe	-	-
Dot Pitch (HxV)	(0.088x3) x 0.264	mm	Dot
Viewing Angle (H/V)	140/120	degree	6 o'clock
Signal Interface	Digital RGB 24/18 bits (LVDS)		16.7M/262K colors
Surface Treatment	Anti-Glare, Hard Coating 3H		
Display Mode	Normally White	-	-



2.3.2 Mechanical Dimensions

Item		Min.	Typ.	Max.	Unit	Note
Dimension	Horizontal	-	243.0	-	mm	±0.5 mm
	Vertical	-	172.6	-		±0.5 mm
	Depth	-	7.9	-		+0.5 mm
Weight		-	335		g	±10 g

3.0 Absolute Maximum Ratings

3.1 Absolute Ratings of Environment Requirement

Item	Symbol	Min.	Max.	Unit	Note
Storage Temperature	Tstg	-30	+ 80	°C	
Operation Temperature (Ambient Temperature)	Top	-20	+ 70	°C	

Note (1) Temperature and relative humidity range are shown in the figure below.

95% RH Max. ($40^{\circ}\text{C} > T_a$)

Maximum wet – bulb temperature at 39°C or less. ($T_a > 40^{\circ}\text{C}$) No condensation.

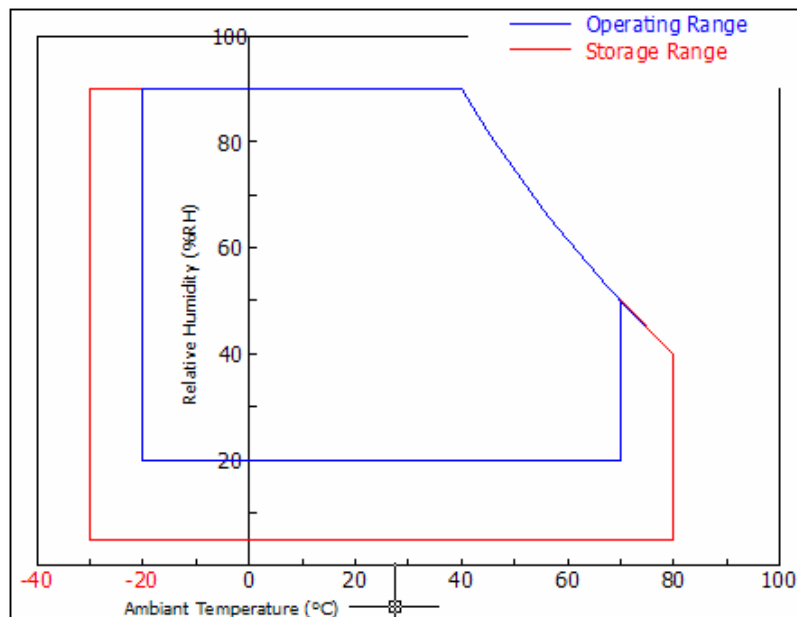



3.2 Electrical Absolute Ratings

3.2.1 TFT-LCD Module

(Ta=25±2°C), V_{gg}=GND=0V)

Item	SYMBOL	Min.	Max.	UNIT	NOTE
Power Supply Voltage	V _{DD}	-0.3	4.0	V	(1),(2)
Logic Input Voltage	V _{i1}	-0.3	V _{DD} +0.3	V	(1),(2)

3.2.2 Backlight Module(LED)

Item	SYMBOL	MIN	MAX	UNIT	NOTE
Input DC Voltage	V _{BL}	-	15	V	(1),(2)

Note (1) Within operating temperature

Note (2) Permanent damage to the device may occur if maximum values are exceeded.

Functional operation should be restricted to the conditions described under normal operating conditions.



4.0 Optical Characteristics

The following items are measured under stable conditions in a dark room or equivalent state.

* Measuring Equipment: BM-5A, PR-650

($V_{DD}=3.3V$, $f_V=60Hz$, $T_a=25\pm 2^\circ C$)

Item	Symbol	Condition	Min.	Typ.	Max.	Unit	Note
Contrast Ratio	CR	At optimized Viewing Angle	400	500	-	-	(1)(2) (4)
Response Time at 25°C	Rising	T_R	-	10	20	ms	(3)
	Falling	T_F	-	20	30		
Luminance(center)	Y_L	$V_{DIM}=\max$	-	1200	-	cd/m ²	(1)(2) (6)
Viewing Angle	Hor.	θ_L	CR \geq 10 at center point	70	-	Degree	(2)(5)
		θ_R		70	-		
	Ver.	θ_H		55	-		
		θ_L		65	-		

Note (1) : Ambient temperature =25°C , and , using the Mode 2 of LED control scheme and $V_{DIM}=0V$ to get the maximum brightness. To be measured in the dark room.

Note (2) : To be measured on the center area of panel with a viewing cone of 1° by Topcon Luminance Meter BM-5, after 10 minutes operation.

Note (3) : Definition of response time:

The output signals of photo detector are measured when the input signals are changed from "black" to "white"(falling time) and from "white" to "black"(rising time), respectively.

The response time is defined as the time interval between the 10% and 90% of amplitudes. Refer to figure as below.

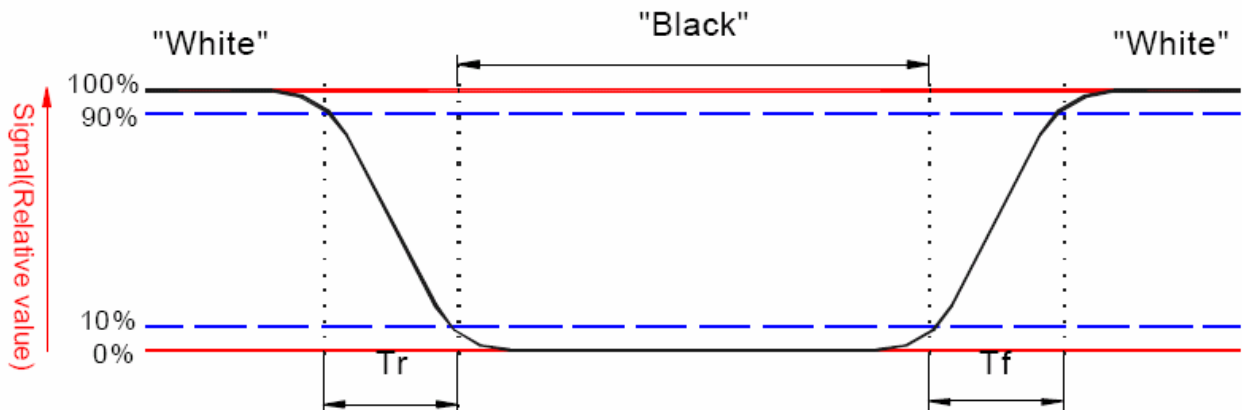

Note (4) : Definition of contrast ratio:

Contrast ratio is calculated with the following formula.

$$\text{Contrast ratio (CR)} = \frac{\text{Photo detector output when LCD is at "White" state}}{\text{Photo detector output when LCD is at "Black" state}}$$

Note (5) : Definition of viewing angle, Refer to figure as below.

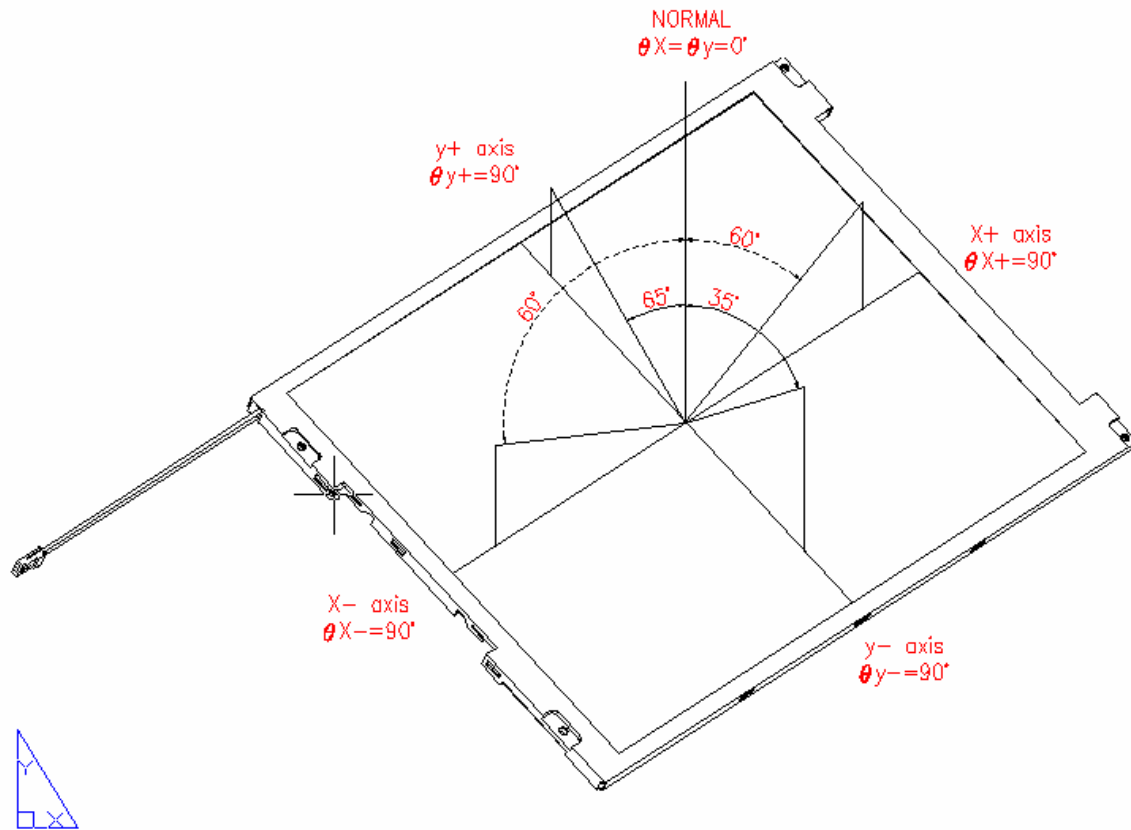

Note (6) : Measured at the center area of the panel when all the input terminals of LCD panel are electrically opened.



5.0 Electrical Characteristics

5.1 AC Timing Characteristics

Signal	Item	Symbol	Min.	Typ.	Max.	Unit	Note
LVDS Clock	Frequency	Fc	36	40	50	MHz	-
	Period	Tc	20.7	25.1	29.9	ns	
Vertical Active Display Term	Frame Rate	Fr	56	60	75	Hz	Tv=Tvd+Tvb
	Total	Tv	606	628	650	Th	-
	Display	Tvd	600	600	600	Th	-
	Blank	Tvb	Tv-Tvd	28	Tv-Tvd	Th	-
Horizontal Active Display Term	Total	Th	920	1056	1240	Tc	Th=Thd+Thb
	Display	Thd	800	800	800	Tc	-
	Blank	Thb	Th-Thd	256	Th-Thd	Tc	-

5.2 DC Characteristics

5.2.1 TFT-LCD Module

Item	Symbol	Min.	Typ.	Max.	Unit	Note	
Power Supply	V _{DD}	3.0	3.3	3.6	V	(1)	
	I _{DD}	White	-	260	-	mA	VDD=3.3V
		Black	-	300	-	mA	
Permissive Input Ripple Voltage	V _{RF}	-	-	100	mV _{P-P}	VDD=3.3V	
LVDS Differential Input Voltage	V _{id}	-100		100	mV		
LVDS Common Input Voltage	V _{ic}		1.2		V		

Note (1) VDD Power-On Condition :

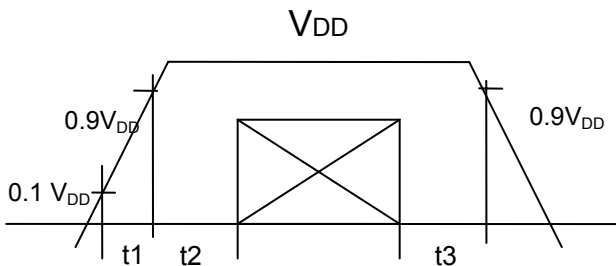

$$0 < t1 \leq 10 \text{ ms}$$

$$0 < t2 \leq 50 \text{ ms}$$

$$t3 \leq 50 \text{ ms}$$



5.2.2 Backlight Unit & LED Driver

Item	Symbol	Min.	Typ.	Max.	Unit	Note
Power Supply	V_{BL}	10.8	12	13.2	V	(2)
	I_{BL}		0.68		Amp	(1)

Note 1 : $V_{BL} = 12$ V, using the Mode 2 of LED control scheme and $V_{DIM} = 0$ V to get the maximum brightness.

Note 2. V_{BL} Power-On Condition for LED driver :

Please make sure the control signals must arrive after the power supply of LED driver, V_{BL} .

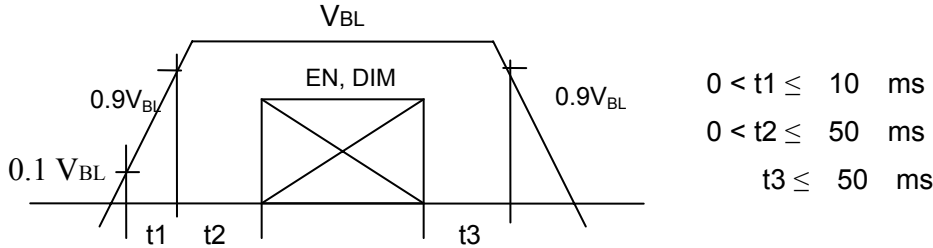

5.3 Input Terminal Pin Assignment

5.3.1 Signal Input Interface

Hirose connector: 20 pin, DF-19K-20P-1H

Mating Connector : DF-19G-20S-1C or equivalent

Pin No	Symbol	Description	Remark
1	V_{CC_IN}	Power supply (3.3V)	-
2	V_{CC_IN}	Power Supply (3.3V)	-
3	GND	Ground	-
4	DPS	Reverse Scan Function (H:Enable, L:NC,Disable)	-
5	RxIN0-	LVDS receiver signal channel 0	R0~R5, G0
6	RxIN0+		
7	GND	Ground	-
8	RxIN1-	LVDS receiver signal channel 1	G1~G5, B0, B1
9	RxIN1+		
10	GND	Ground	-
11	RxIN2-	LVDS receiver signal channel 2	B2~B5, DE, Hsync, Vsync
12	RxIN2+		
13	GND	Ground	-
14	CLKIN-	LVDS receiver signal clock	LVDS Level Colck
15	CLKIN+		
16	GND	Ground	-
17	RxIN3-	LVDS receiver signal channel 3	R6~R7, G6~G7, B6~B7
18	RxIN3+		
19	NC	No Connection	-
20	SEL 6/8	6 bits or 8 bits Input LVDS Setting	Note 1



Note 1 : Please set HIGH to “SEL 6/8” for 8 bits mode, and use RxIN3 pair for R6~R7, G6~G7 and B6~B7. And set “LOW” or NC to “SEL 6/8” pin for 6 bits mode, leave the “RxIN3” pair open if 6 bits mode is used.

5.3.2 LED Driver Unit

Connector: ACES 88290-0601 pitch 2.0mm 6 pins CN

Or JST S6B-PH-K-S

Mode 1 :

Matching Connector : ACES 86809-0600 CN

Pin No.	Symbol	Description	Remark
1	V _{BL}	Power Supply for LED Driver	
2	V _{BL}	Power Supply for LED Driver	
3	EN	LED Enable & Dimming Control Input	Note 1
4	DIM	Connect this pin to GND at this mode	Note 2
5	GND	Ground Pin for LED Driver	
6	GND	Ground Pin for LED Driver	

Note 1 : The “Enable & Dimming Control” of the LED driver shares the same pinning.

The LED backlight will turn on when the input voltage of this pin exceeds +0.6V.

The LED current/brightness will be adjustable by applying an analog voltage between +0.8 ~ +1.4V(Max. Brightness).

Note 2: The “DIM” pin should be connected to GND in order to get the full brightness.

Mode 2:

Pin No.	Symbol	Description	Remark
1	V _{BL}	Power Supply for LED Driver	
2	V _{BL}	Power Supply for LED Driver	
3	EN	LED Enable Control Input	Note 1
4	DIM	Dimming Control Input	Note 2
5	GND	Ground Pin for LED Driver	
6	GND	Ground Pin for LED Driver	

Note 1 : Disable V_{EN}<0.6 V, Enable V_{EN}>1.8 V

Note 2 : Max Brightness V_{DIM} : 0V, Min Brightness V_{DIM} : 2.2V (≈ 0 Nit)

Mode 3:

Pin No.	Symbol	Description	Remark
1	V _{BL}	Power Supply for LED Driver	
2	V _{BL}	Power Supply for LED Driver	
3	EN	PWM Control Pulse Input	Note 1, 2
4	DIM	Connect this pin to GND at this mode	Note 3
5	GND	Ground Pin for LED Driver	



6	GND	Ground Pin for LED Driver	
---	-----	---------------------------	--

Note 1: Valley of PWM Pulse $V_{P_{PWM}} < 0.6\text{ V}$, Peak of PWM Pulse $V_{P_{PWM}} > 1.8\text{ V}$

Note 2: The frequency of each completed PWM cycle: 100~300 Hz

Note 3: The "DIM" pin should be connected to GND in order to get the full brightness.

5.4 Color Data Reference

The below table is about input signal, Basic display colors and gray scale of each color.

0 : Low Level Voltage 1 : High Level Voltage

Each basic color can be displayed in 128/64 gray scales from 8/6 bit data signals. With the combination of total 24/18 bit data signals, the 16.7M/262,144 color display can be achieved on the screen.

- Please refer to the next page



	Colors & Gray Scale	Data Signal																											
		Gray Scale	R0	R1	R2	R3	R4	R5	R6	R7	G0	G1	G2	G3	G4	G5	G6	G7	B0	B1	B2	B3	B4	B5	B6	B7			
Basic Color	Black	-	0	0	0	0	0	0	0	0	0	0	0	0	0	0	0	0	0	0	0	0	0	0	0	0	0	0	
	Blue	-	0	0	0	0	0	0	0	0	0	0	0	0	0	0	0	0	1	1	1	1	1	1	1	1	1	1	
	Green	-	0	0	0	0	0	0	0	0	1	1	1	1	1	1	1	1	0	0	0	0	0	0	0	0	0	0	
	Cyan	-	0	0	0	0	0	0	0	0	1	1	1	1	1	1	1	1	1	1	1	1	1	1	1	1	1	1	
	Red	-	1	1	1	1	1	1	1	1	0	0	0	0	0	0	0	0	0	0	0	0	0	0	0	0	0	0	
	Magenta	-	1	1	1	1	1	1	1	1	0	0	0	0	0	0	0	0	1	1	1	1	1	1	1	1	1	1	
	Yellow	-	1	1	1	1	1	1	1	1	1	1	1	1	1	1	1	1	0	0	0	0	0	0	0	0	0	0	
	White	-	1	1	1	1	1	1	1	1	1	1	1	1	1	1	1	1	1	1	1	1	1	1	1	1	1	1	
Gray Scale of Red	Black	GS0	0	0	0	0	0	0	0	0	0	0	0	0	0	0	0	0	0	0	0	0	0	0	0	0	0	0	
	↑	GS1	1	0	0	0	0	0	0	0	0	0	0	0	0	0	0	0	0	0	0	0	0	0	0	0	0	0	
	Darker	GS2	0	1	0	0	0	0	0	0	0	0	0	0	0	0	0	0	0	0	0	0	0	0	0	0	0	0	
	↑	↓					↓							↓											↓				
	↓	↓					↓							↓											↓				
	Brighter	GS253	1	0	1	1	1	1	1	1	0	0	0	0	0	0	0	0	0	0	0	0	0	0	0	0	0	0	
	↓	GS254	0	1	1	1	1	1	1	1	0	0	0	0	0	0	0	0	0	0	0	0	0	0	0	0	0	0	
	Red	GS255	1	1	1	1	1	1	1	1	0	0	0	0	0	0	0	0	0	0	0	0	0	0	0	0	0	0	
Gray Scale of Green	Black	GS0	0	0	0	0	0	0	0	0	0	0	0	0	0	0	0	0	0	0	0	0	0	0	0	0	0	0	
	↑	GS1	0	0	0	0	0	0	0	0	1	0	0	0	0	0	0	0	0	0	0	0	0	0	0	0	0	0	
	Darker	GS2	0	0	0	0	0	0	0	0	0	1	0	0	0	0	0	0	0	0	0	0	0	0	0	0	0	0	
	↑	↓					↓							↓											↓				
	↓	↓					↓							↓											↓				
	Brighter	GS253	0	0	0	0	0	0	0	0	1	0	1	1	1	1	1	1	0	0	0	0	0	0	0	0	0	0	
	↓	GS254	0	0	0	0	0	0	0	0	0	1	1	1	1	1	1	1	0	0	0	0	0	0	0	0	0	0	
	Green	GS255	0	0	0	0	0	0	0	0	1	1	1	1	1	1	1	1	0	0	0	0	0	0	0	0	0	0	
Gray Scale of Blue	Black	GS0	0	0	0	0	0	0	0	0	0	0	0	0	0	0	0	0	0	0	0	0	0	0	0	0	0	0	
	↑	GS1	0	0	0	0	0	0	0	0	0	0	0	0	0	0	0	0	1	0	0	0	0	0	0	0	0	0	
	Darker	GS2	0	0	0	0	0	0	0	0	0	0	0	0	0	0	0	0	0	1	0	0	0	0	0	0	0	0	
	↑	↓					↓							↓											↓				
	↓	↓					↓							↓											↓				
	Brighter	GS253	0	0	0	0	0	0	0	0	0	0	0	0	0	0	0	0	1	0	1	1	1	1	1	1	1	1	
	↓	GS254	0	0	0	0	0	0	0	0	0	0	0	0	0	0	0	0	0	1	1	1	1	1	1	1	1	1	
	Blue	GS255	0	0	0	0	0	0	0	0	0	0	0	0	0	0	0	0	1	1	1	1	1	1	1	1	1	1	

This specification data sheet is an intellectual property of PowerView Display Corporation. Any copy, reproduction or modification without written permission of PowerView Display Corporation is not allowed.

5.5 Input Timing Chart

* Note :

The Hs and Vs shown on this diagram are for reference purpose only for users to identify and better understand the synchronous marking on the timing chart. The Hs and Vs signal is not needed to drive this LCD module.

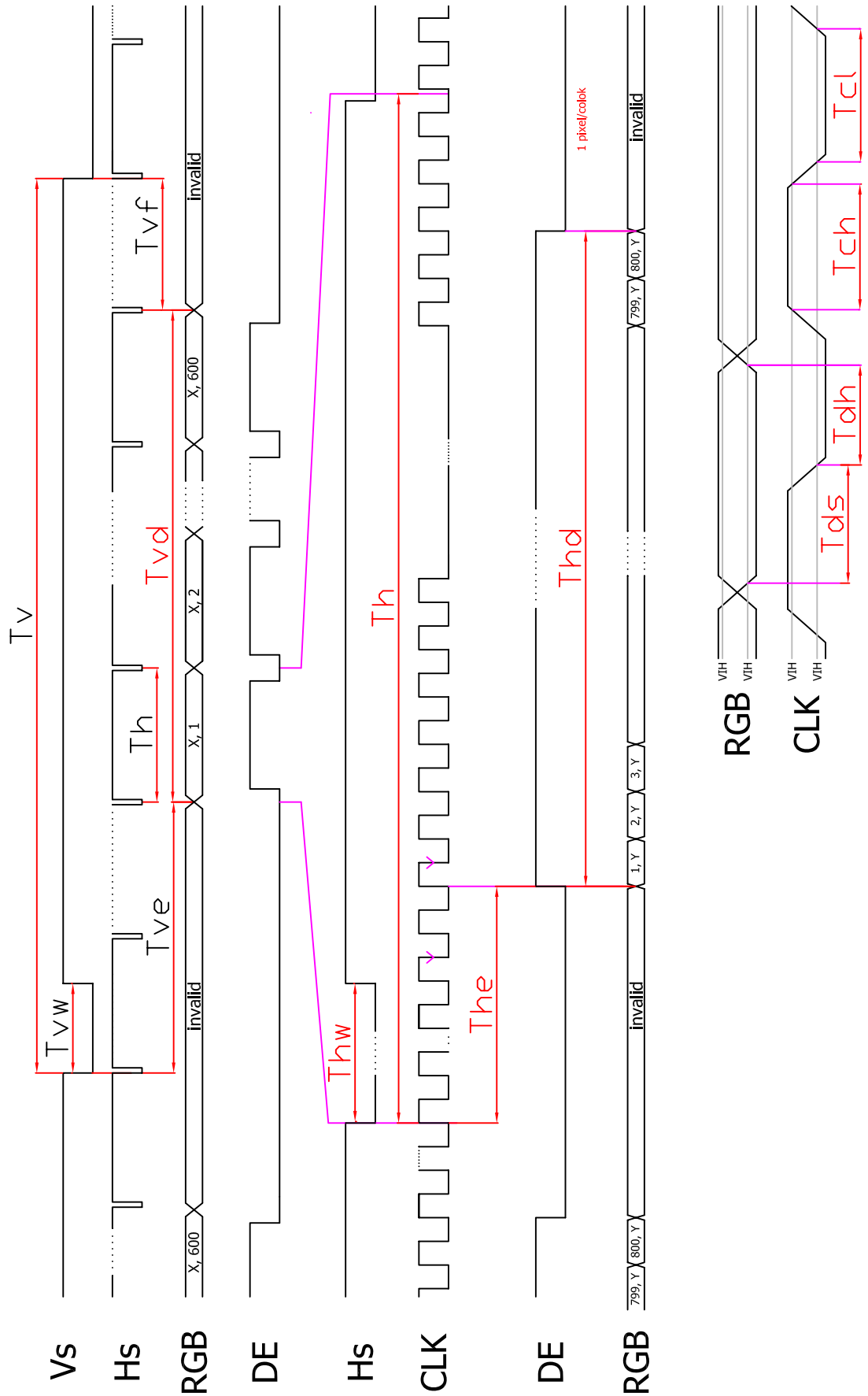

6.0 Pixel Format Image

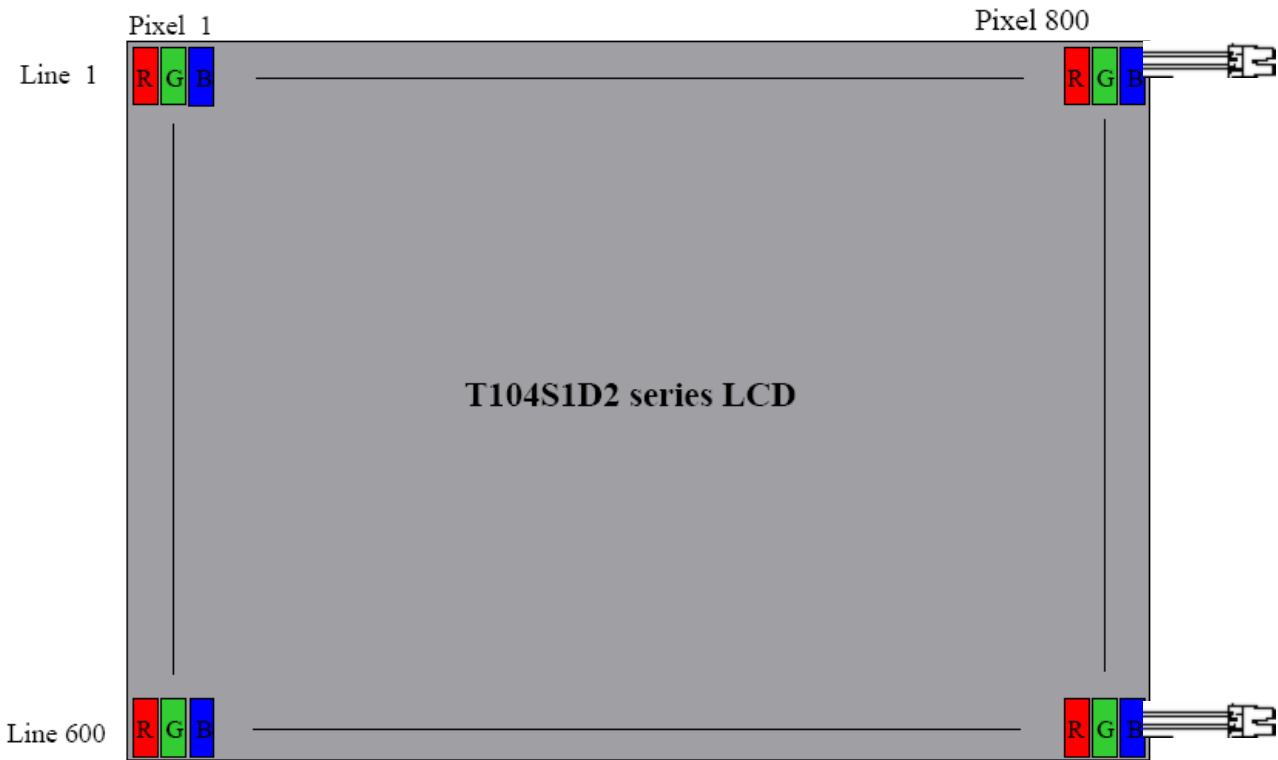

7.0 Display Outline Dimensions

7.1 Display Outline Dimensions

- Please refer to the next page.

REV	EC NUMBER	DESCRIPTION	DATE
1	XXXXXX	XXXXXX	

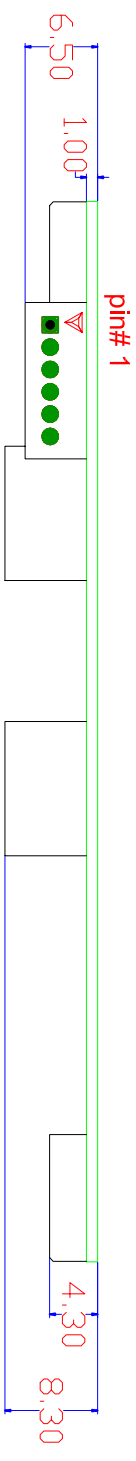
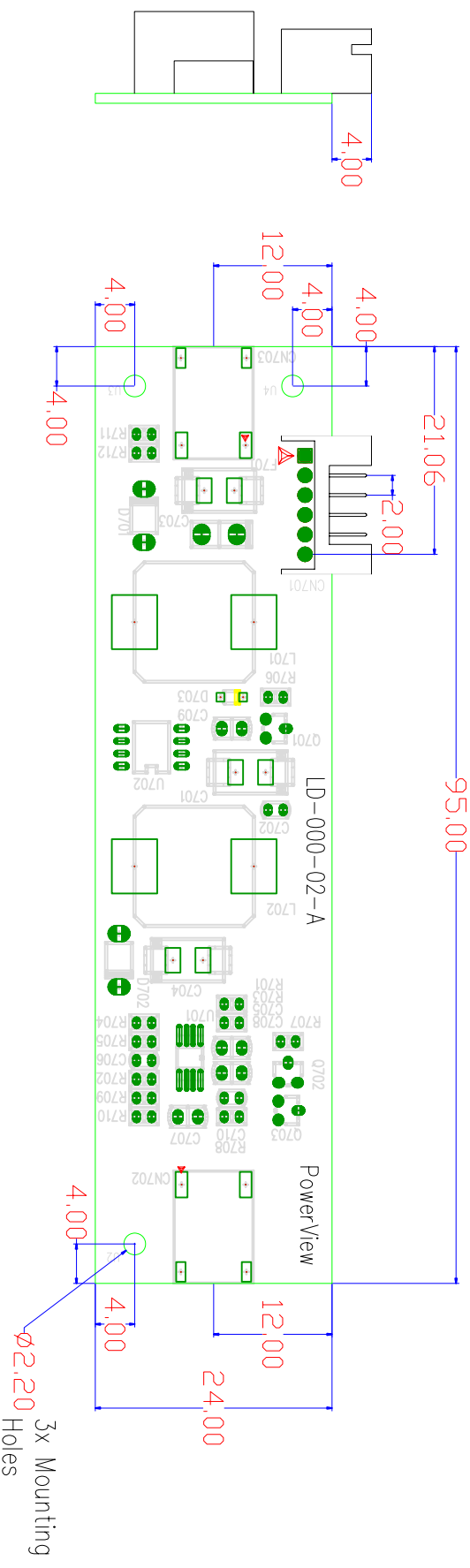

REV	EC NUMBER	DESCRIPTION	DATE
1	XXXXXX	XXXXXX	

POVERVIEW DISPLAY CORPORATION		All Rights Reserved	
MATERIAL	See notes	DATE	3rd ANGLE
FINISH	Finish	DATE	
APPROVED		DATE	
CHECKED		DATE	
DESIGNED	Tim	DATE	

ITEM	DESCRIPTION	QTY	UNIT
1	GENERAL PURPOSE BOARD	1	PCB
2	LED DRIVER FOR T1045102 4.2 1200 MHZ	1	PCB



8.0 Labeling, Packaging & Others

* Labeling

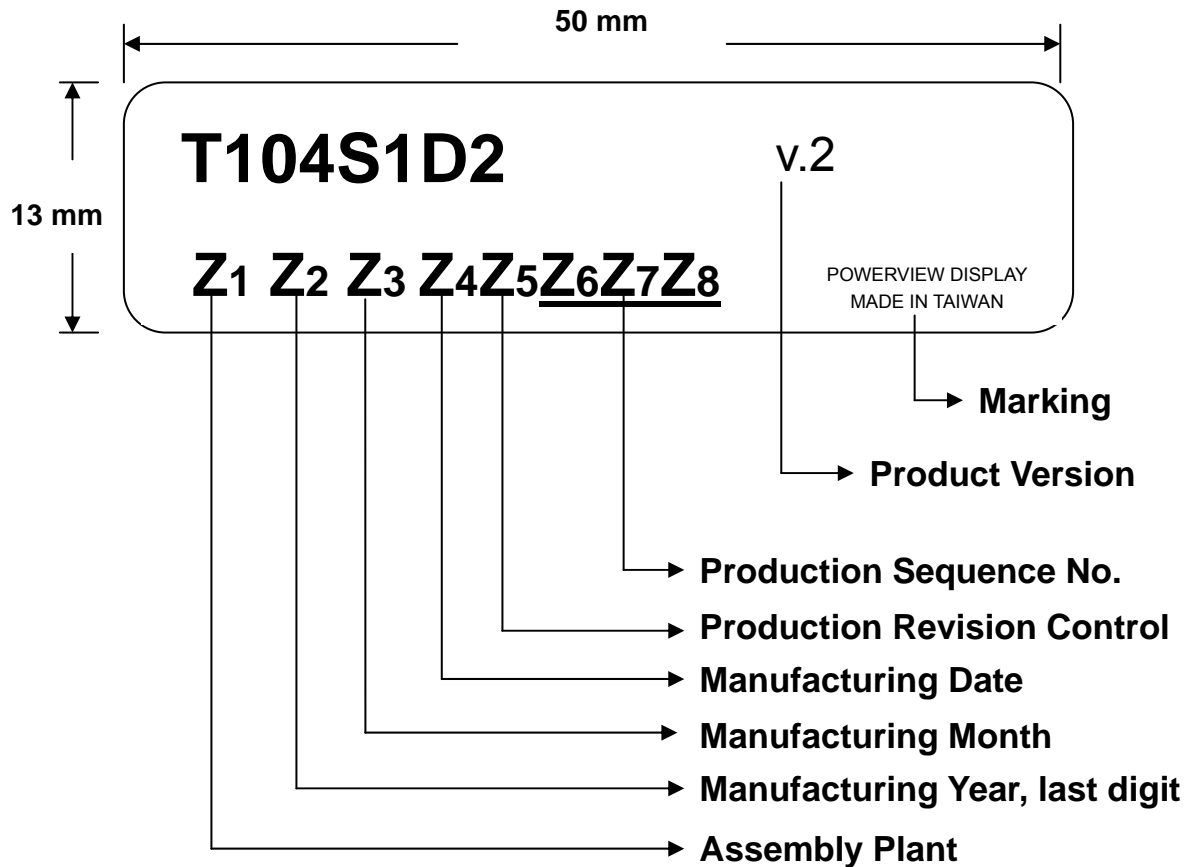

* Carton Packaging

- Please refer to the next page for packaging information.



T104S1D2 Packaging

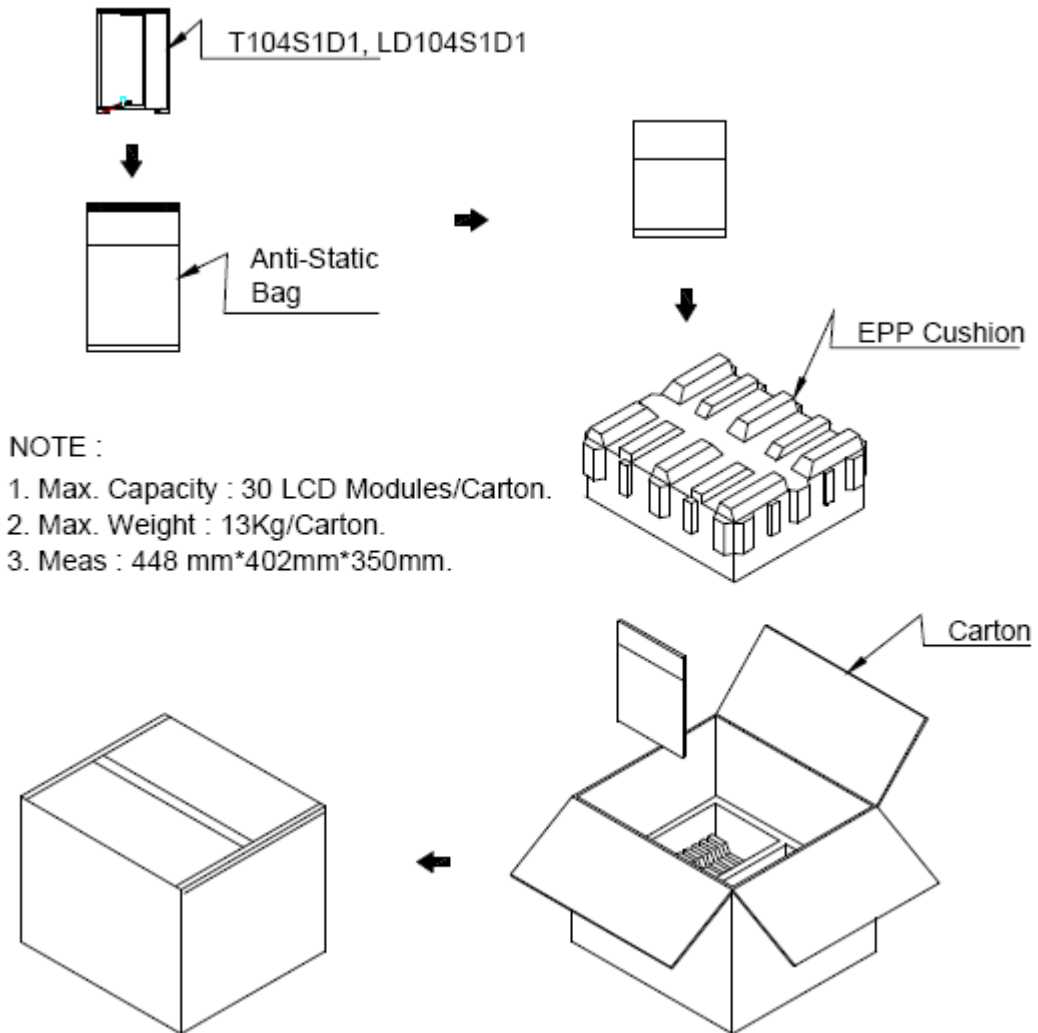



9.0 General Notice

9.1 Reliability Test Items (Note 2)

No.	Test Items	Conditions	Remark
1	High Temperature Storage	Ta= + 80°C 240 Hrs	
2	Low Temperature Storage	Ta= - 30°C 240 Hrs	
3	High Temperature Operation	Ta= + 70°C 240 Hrs	
4	Low Temperature Operation	Ta= - 20°C 240 Hrs	
5	High Temperature and High Humidity	Tp= 40°C, 90%RH 240 Hrs	operation
6	Heat Shock	-25~80°C/200 cycles 1Hr/cycle	Non-operation
7	Electrostatic discharge	±200V, 200pF(0Ω), once for each terminal	Non-operation
8	Vibration	Frequency range : 8~33.3 Hz Stoke : 1.3mm Sweep : 2.9G, 33.3~400Hz Cycle : 15 minutes 2 hours for each direction of X,Z 4 hours for Y direction	JIS C7021, A-10 Condition A
9	Mechanical Shock	100G, 6ms, ±X±Y±Z 3 times for each direction	JIS C7021, A-7 Condition C
10	Vibration (with carton)	Random vibration : 0.015G ² /Hz from 5~200Hz -6dB/octave from 200~500Hz	IEC 68-34
11	Drop (with carton)	Height : 60 cm 1 corner, 3 edges, 6 surfaces	JIS Z0202

Note 1: Ta: Ambient temperature.

Note 2: In the standard conditions, there is not display function NG issue occurred. All the cosmetic specification is judged before the reliability stress.



9.2 Storage, Operation & Others

- (a) Do not leave the panel in high temperature, and high humidity for a long time.
It is highly recommended to store the module with temperature from 0 to 35°C and relative humidity of less than 70%.
- (b) Do not store the TFT-LCD module in direct sunlight.
- (c) The module shall be stored in a dark place. It is prohibited to apply sunlight or fluorescent light during the store.
- (d) Do not connect, disconnect the module in the "Power On" condition.
- (e) Power supply should always be turned on/off by the item 3.2 "Electrical Absolute Ratings"
- (f) The liquid-crystal is deteriorated by ultraviolet rays. Do not leave it in direct sunlight and strong ultraviolet rays for many hours.
- (g) Avoid condensation of water. It may result in improper operation or disconnection of electrode.
- (h) Do not exceed the absolute maximum rating value. (the supply voltage variation, input voltage variation, variation in part contents and environmental temperature, and so on) Otherwise the panel may be damaged.
- (i) If the panel displays the same pattern continuously for a long period of time, it can be the situation when the image "Sticks" to the screen.
- (j) This panel has its circuitry FPC on the bottom side and should be handled carefully in order not to be stressed.