



TFT-LCD MONITOR

Product Information

MODEL NO. : T070W2D2 v.1

Date : 2007.12.12 version 1.1

Prepared by : Jason Cheng

Jason Cheng, Engineer, Product Development Div.

Approved by : Kevin Hsieh

Kelvin Hsieh, Senior Engineer, Product Development Div.

This TFT LCD Monitor is distributed by:



Display Solution AG
Talhofstraße 32a
D-82205 Gilching
GERMANY
Fon +49 (0)8105 / 73 403 - 0
Fax +49 (0)8105 / 73 403 - 79
E-Mail: info@display-solution.com
Internet: www.display-solution.com

This product specification is subject to change without any notice.



Records of Revision

Date	Rev. No.	Summary	Page
2007/9/4	01	First MP Release	
2007/12/12	1.1	6.0Pixel Format Image – B/L wire output correction	15
		8.0 Pin#1 location on LCD indicated	17



Contents		Page
1.0 Handling Precautions	-----	4
2.0 General Description	-----	5
2.1 General Application	----- 5	
2.2 Main Features	----- 5	
2.3 General Information	----- 5	
2.3.1 Display Characteristics	----- 5	
2.3.2 Mechanical Dimensions	----- 6	
3.0 Absolute Maximum Ratings	-----	6
3.1 Absolute Ratings of Environment Requirement	----- 6	
3.2 Electrical Absolute Ratings	----- 6	
3.2.1 TFT-LCD Module	----- 6	
3.2.2 DC-AC Module	----- 6	
4.0 Optical Characteristics	-----	7
5.0 Electrical Characteristics	-----	9
5.1 AC Timing Characteristics	----- 9	
5.2 DC Characteristics	----- 9	
5.2.1 TFT-LCD Module	----- 9	
5.2.2 DC-AC Module and Backlight Unit	----- 10	
5.3 Input Terminal Pin Assignment	----- 11	
5.3.1 Signal Input Interface	----- 11	
5.3.2 LED Driver Unit Interface	----- 12	
5.4 Color Data Reference	----- 12	
5.5 Input Timing Chart	----- 14	
6.0 Pixel Format Image	-----	15
7.0 Display Outline Dimensions	-----	15
8.0 Labeling, Packaging & Others	-----	18
9.0 General Notices	-----	20
9.1 Reliability Test Item	----- 20	
9.2 Storage, Operation & Others	----- 21	



1.0 Handling Precaution

- 1.) Handle with care. Pay attention not to press or scratch the surface of the monitor, especially the polarizer. Do not twist or bend the monitor. It may cause un-recoverable damage.
- 2.) Do not drop or bump the monitor since this monitor contains fragile glass components. Breakage of this monitor might cause leakage of the liquid crystal sealed inside the glasses. Do not touch the liquid crystal liquid in case of leakage. **Flush with massive water immediately in case of contact with your skin by liquid crystal fluid and call for doctor for immediate medical treatment.**
- 3.) Be sure to turn off power supply while plug or un-plug the power input connector.
- 4.) Clean up the polarizer only with soft solvent if necessary. The desirable cleaners are water, IPA(Isopropyl Alcohol) or Hexane. Do not use Ketone type materials (ex. Acetone), Ethyl alcohol, toluene, Ethyl acid or Methyl chloride. It will permanently damage the polarizer due to chemical reaction. 5.) Wipe off fluid drop immediately to prevent from possible discoloration or spots on the polarizer.
- 6.) Do not twist nor bend the monitor structure, even momentarily. Bending or twisting torque may likely damage the internal components of the monitor.
- 7.) The cold cathode fluorescent lamp in LCD contains small amount of mercury (Hg). Please refer to the design specification for application and the local regulations and environmental laws for disposal purpose.
- 8.) Protect the monitor from static environment to prevent from damage to the CMOS gate array IC.



2.0 General Description

T070W2D2 v.1 is a 7 inch (15:9 aspect ratio) color active matrix TFT LCD monitor with slim outlook and excellent display performance driven by a pure **DIGITAL** CMOS interface. This monitor supports 800(H) x RGB x 480(V), stripe color pixel format, and 262,144 colors (RGB 6 bits data) with outstanding color image and **ALL-IN-ONE** functionality, including a built-in DC-DC logic circuitry. Its outstanding performances with wide operation temperature range, **-30 ~ 70°C**, sunlight readable brightness, **800 nits(typ.)** and super wide viewing angle(140° /120°) make this monitor very suitable for applications in server environments. Its slim mechanical design and low power consumption provide high design flexibilities in all kind of applications for customers.

2.1 General Applications

- Display terminal for applications of Portable Devices, Video Player, Navigation, Industrial, Medical, Gaming, Amusement or more

2.2 Main Features

- 15:9 Display Aspect Ratio
- Wide Operation Temperature Range & Super Wide Viewing Angle
- LED Backlight with **Sunlight Readable Brightness**
- High Contrast Ratio
- Digital CMOS Interface
- Scanning Mode Selections
- Thin and Light Weight
- Built-in DC-DC Logic Circuit & Additional LED Driver Available

2.3 General Information

2.3.1 Display Characteristics

Item	Specification	Unit	Note
Display Area (HxV)	152.4 (H) x 91.44 (V)	mm	7" Diagonal
Driver Element	a-Si TFT Active Matrix	-	-
Number of Pixels (HxV)	800 x RGB x 480	pixel	Wide 16:9
Pixel Arrangement	R.G.B Vertical Stripe	-	-
Pixel Pitch (HxV)	0.1905 x 0.1905	mm	Pixel
Display Mode	Normally White	-	-
Viewing Angle (H/V)	140/120	degree	6 o'clock
Signal Interface	Digital RGB 18 bits		262K colors



2.3.2 Mechanical Dimensions

Item		Min.	Typ.	Max.	Unit	Note
Dimension	Horizontal	-	167.9	-	mm	±0.3 mm
	Vertical	-	110.1	-		±0.3 mm
	Depth	-	11.04	-		w/o LED DR
Weight			300		g	±10 g

3.0 Absolute Maximum Ratings

3.1 Absolute Ratings of Environment Requirement

Item	Symbol	Min.	Max.	Unit	Note
Storage Temperature	Tstg	-40	80	°C	
Operation Temperature (Ambient Temperature)	Topr	-30	70	°C	

3.2 Electrical Absolute Ratings

3.2.1 TFT-LCD Module

(Ta=25±2°C), Vgg=GND=0V)

Item	SYMBOL	Min.	Max.	UNIT	NOTE
Power Supply Voltage	V _{DD}	-0.3	6.0	V	(1),(2)
Input Voltage	V _{i1}	-0.3	6.3	V	(1),(2),(3)

3.2.2 LED Driver Module

Item	SYMBOL	MIN	MAX	UNIT	NOTE
Power Supply Voltage	V _{BL}	-0.3	15	V	(1),(2)
Input Voltage	V _{i2}	-0.3	5.5	V	(1),(2),(4)

Note (1) Within operating temperature

Note (2) Permanent damage to the device may occur if maximum values are exceeded.

Functional operation should be restricted to the conditions described under normal operating conditions.

Note (3) For all pins except power and ground pins

Note (4) For pins "DIM" and "ENA"



4.0 Optical Characteristics

The following items are measured under stable conditions in a dark room or equivalent state.

* Measuring Equipment: BM-5A, PR-650

($V_{DD}=3.3V$, $f_V=60Hz$, $f_H=35.9KHz$, $T_a=25\pm 2^\circ C$)

Item		Symbol	Condition	Min.	Typ.	Max.	Unit	Note
Contrast Ratio		CR	At optimized Viewing Angle	400	500	-		(4)
Response Time at 25°C	Rising	T_R	$\theta=0^\circ$	-	10	20	ms	(3)
	Falling	T_F		-	15	30		
Luminance		Y_L	$V_{Dim}=V_{max}$, 25°C	700	800		cd/m^2	
Color Chromaticity (CIE 1931)	White	W_X	$\theta=0^\circ$		TBD			(6)
		W_Y	$\theta=0^\circ$		TBD			
Viewing Angle	Hor.	θ_L	CR \geq 10 at center point	60	70	-	Degree	(5)
		θ_R		60	70	-		
	Ver.	θ_H		40	50	-		
		θ_L		60	70	-		
Luminance Uniformity		Y_u	$\theta=0^\circ$	70	75	-	%	

Note (1) : Ambient temperature =25°C , and , using the Mode 2 of LED control scheme and $V_{DIM}=0V$ to get the maximum brightness. To be measured in the dark room.

Note (2) : To be measured on the center area of panel with a viewing cone of 1° by Topcon luminance meter BM-5, after 10 minutes operation.

Note (3) : Definition of response time:

The output signals of photo detector are measured when the input signals are changed from “black” to “white”(falling time) and from “white” to “black”(rising time), respectively.

The response time is defined as the time interval between the 10% and 90% of amplitudes. Refer to figure as below.

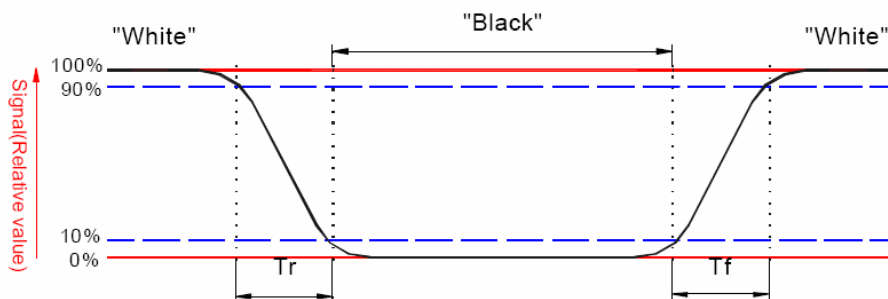

Note (4) : Definition of contrast ratio:

Contrast ratio is calculated with the following formula.

$$\text{Contrast ratio (CR)} = \frac{\text{Photo detector output when LCD is at "White" state}}{\text{Photo detector output when LCD is at "Black" state}}$$

Note (5) : Definition of viewing angle, Refer to figure as below.

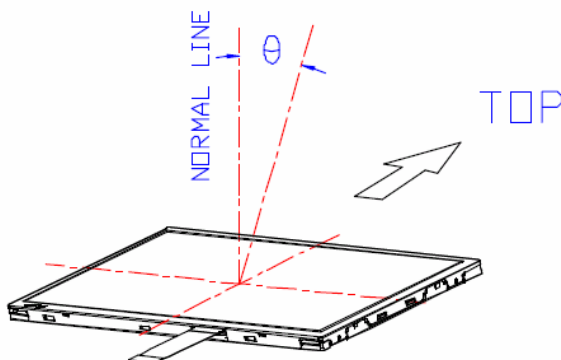

Note (6) : Measured at the center area of the panel when all the input terminals of LCD panel are electrically opened.

Note (7) : Definition of Uniformity (δW):

Measure the luminance at gray level 63 of 5 defined points.

$$\delta W = \frac{\text{Minimum [L(1),L(2),L(3),L(4),L(5)]}}{\text{Maximum [L(1),L(2),L(3),L(4),L(5)]}}$$

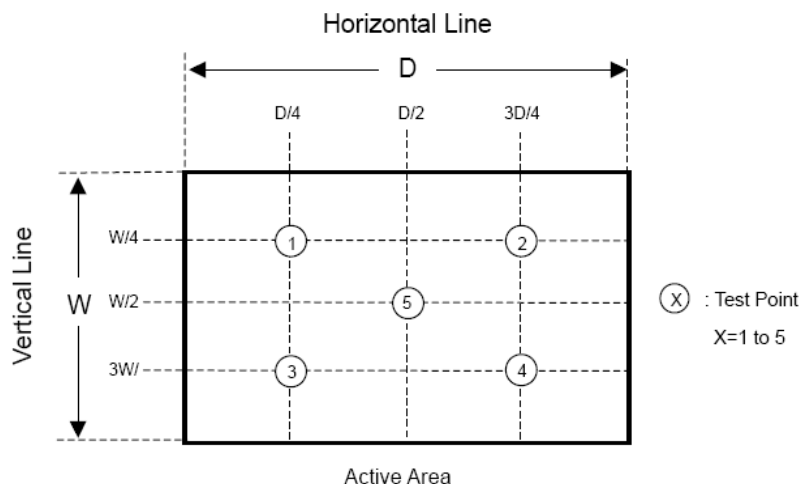



5.0 Electrical Characteristics

5.1 AC Timing Characteristics

Item	Symbol	Min.	Typ.	Max.	Unit	Note
Clock Frequency	F_{ck}	-	33.3	50	MHz	
Clock Duty Ratio	$T_{ch}/(T_{ch}+T_{cl})$	45	50	55	%	
Hsync Period	T_h	-	928	-	clk	
	τ_h	-	27.86	-	μs	$\tau_h=T_h/F_{ck}$
Hsync Pulse Width	T_{hw}	-	48	-	clk	
Hsync Width + Back Porch	T_{he}		88		clk	
Vsync Period	T_v	-	525	-	T_h	
Vsync Pulse Width	T_{vw}	-	3	-	T_h	
Vsync Width + Back Porch	T_{ve}	-	29	-	T_h	
Hsync/Vsync Phase Shift	T_{vpd}	2	-	-	clk	
Horizontal Display Period	T_{hd}		800		clk	
Vertical Display Period	T_{vd}		480		T_h	
Hsync Clock Shift	T_{hc}	10	-	$(T_{ch}+T_{cl})-10$	ns	
Data Setup Time	T_{ds}	5	-	-	ns	
Data Hold Time	T_{ch}	10	-	-	ns	

5.2 DC Characteristics

5.2.1 TFT-LCD Module

Item	Symbol	Min.	Typ.	Max.	Unit	Note
Supply Voltage	V_{DD}	3.0	3.30	3.6	V	(1)
	I_{DD}	-	(260)	(300)	mA	(2)
Permissive Input Ripple Voltage	V_{RF}	-	-	100	mV _{P-P}	$V_{DD}=+5V$
Input Logic High Voltage	V_{IH}	$0.7V_{DD}$	-	V_{cc}	mV	
Input Logic High Voltage	V_{IL}	0	-	$0.3 V_{DD}$	V	(3)



Note (1) VDD Power-On condition :

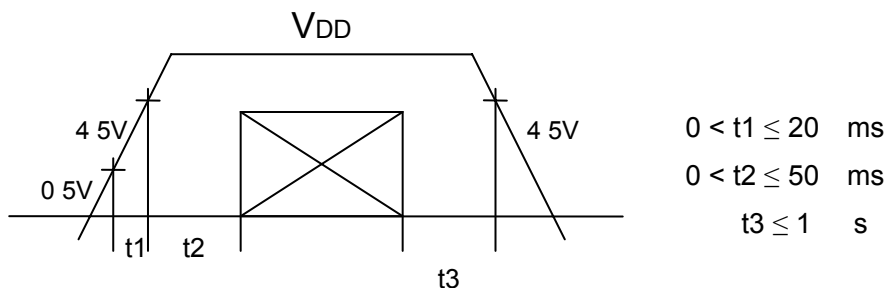

Note (2) Conditions for current consumption :

8 Gray Scale Pattern, VDD=3.3V, $f_H=27.86\text{KHz}$, $f_V=60.0\text{Hz}$, $f_{CLK}=33.3\text{MHz}$

Note (3) DCLK, DE, R0~R5, G0~G5, B0~B5

5.2.2 Backlight Unit and LED Driver (Note 1)

Item	Symbol	Min.	Typ.	Max.	Unit	Note
Power Supply	V_{BL}	10.8	12	13.2	V	
	I_{BL}		0.48		Amp	$V_{BL} = 12V$
Operation Life Time	Hr	30,000			Hours	Note 2

Note 1 : $V_{BL} = 12V$, using the Mode 2 of LED control scheme and $V_{DIM} = 0V$ to get the maximum brightness.

Note 2 : 50% brightness constantly operated at 25°C ambient environment..

5.3 Input Terminal Pin Assignment

5.3.1 Signal Input Interface

Hirose FFC Connector: 40 pin 0.5mm pitch HRS FH19-40S-0.5SH

Pin No	Symbol	Description	Remark
1	GND	Power ground	-
2	GND	Power ground	-
3	NC	No Connection	-
4	VCC	Power supply for digital circuit (+3.3V)	-
5	VCC	Power supply for digital circuit (+3.3V)	-
6	VCC	Power supply for digital circuit (+3.3V)	-
7	VCC	Power supply for digital circuit (+3.3V)	-
8	NC	No Connection	-
9	DE	Data enable	-
10	GND	Power ground	-
11	GND	Power ground	-
12	GND	Power ground	-



13	B5	Blue data input (MSB)	-
14	B4	Blue data input	-
15	B3	Blue data input	-
16	GND	Power ground	-
17	B2	Blue data input	-
18	B1	Blue data input	-
19	B0	Blue data input(LSB)	-
20	GND	Power ground	-
21	G5	Green data input(MSB)	
22	G4	Green data input	
23	G3	Green data input	
24	GND	Power ground	
25	G2	Green data input	
26	G1	Green data input	
27	G0	Green data input(LSB)	
28	GND	Power ground	
29	R5	Red data input(MSB)	
30	R4	Red data input	
31	R3	Red data input	
32	GND	Power ground	
33	R2	Red data input	
34	R1	Red data input	
35	R0	Red data input(LSB)	
36	GND	Power ground	
37	GND	Power ground	
38	DCLK	Sample clock	
39	GND	Power ground	
40	GND	Power ground	

5.3.2 LED Driver Unit

Connector: ACES 88290-0601 pitch 2.0mm 6 pins CN

Or JST S6B-PH-K-S

Mode 1 :

Matching Connector : ACES 86809-0600 CN

Pin No.	Symbol	Description	Remark
1	V _{BL}	Power Supply for LED Driver	
2	V _{BL}	Power Supply for LED Driver	
3	EN	LED Enable & Dimming Control Input	Note 1
4	DIM	Connect this pin to GND at this mode	Note 2



5	GND	Ground Pin for LED Driver	
6	GND	Ground Pin for LED Driver	

Note 1 : The “Enable & Dimming Control” of the LED driver shares the same pinning.

The LED backlight will turn on when the input voltage of this pin exceeds +0.6V.

The LED current/brightness will be adjustable by applying an analog voltage between +0.8 ~ +1.4V(Max. Brightness).

Note 2: The “DIM” pin should be connected to GND in order to get the full brightness.

Mode 2:

Pin No.	Symbol	Description	Remark
1	V _{BL}	Power Supply for LED Driver	
2	V _{BL}	Power Supply for LED Driver	
3	EN	LED Enable Control Input	Note 1
4	DIM	Dimming Control Input	Note 2
5	GND	Ground Pin for LED Driver	
6	GND	Ground Pin for LED Driver	

Note 1 : Disable V_{EN}<0.6 V, Enable V_{EN}>1.8 V

Note 2 : Max Brightness V_{DIM} : 0V, Min Brightness V_{DIM} : 2.2V (≈ 0 Nit)

Mode 3:

Pin No.	Symbol	Description	Remark
1	V _{BL}	Power Supply for LED Driver	
2	V _{BL}	Power Supply for LED Driver	
3	EN	PWM Control Pulse Input	Note 1, 2
4	DIM	Connect this pin to GND at this mode	Note 3
5	GND	Ground Pin for LED Driver	
6	GND	Ground Pin for LED Driver	

Note 1: Valley of PWM Pulse V_{PWM}<0.6 V, Peak of PWM Pulse V_{PWM} >1.8 V

Note 2: The frequency of each completed PWM cycle: 100~300 Hz

Note 3: The “DIM” pin should be connected to GND in order to get the full brightness.

5.4 Color Data Reference

The below table is about nput signal, Basic display colors and gray scale of each color.

0 : Low Level Voltage 1 : High Level Voltage

Each basic color can be displayed in 64 gray scales from 6 bit data signals. With the combination of total 18 bit data signals, the 262,144 color display can be achieved on the screen.

- Please refer to the next page



	Colors & Gray Scale	Data Signal																		
		Gray Scale	R0	R1	R2	R3	R4	R5	G0	G1	G2	G3	G4	G5	B0	B1	B2	B3	B4	B5
Basic Color	Black	-	0	0	0	0	0	0	0	0	0	0	0	0	0	0	0	0	0	0
	Blue	-	0	0	0	0	0	0	0	0	0	0	0	0	1	1	1	1	1	1
	Green	-	0	0	0	0	0	0	1	1	1	1	1	1	0	0	0	0	0	0
	Cyan	-	0	0	0	0	0	0	1	1	1	1	1	1	1	1	1	1	1	1
	Red	-	1	1	1	1	1	1	0	0	0	0	0	0	0	0	0	0	0	0
	Magenta	-	1	1	1	1	1	1	0	0	0	0	0	0	1	1	1	1	1	1
	Yellow	-	1	1	1	1	1	1	1	1	1	1	1	1	0	0	0	0	0	0
	White	-	1	1	1	1	1	1	1	1	1	1	1	1	1	1	1	1	1	1
Gray Scale of Red	Black	GS0	0	0	0	0	0	0	0	0	0	0	0	0	0	0	0	0	0	0
	↑	GS1	1	0	0	0	0	0	0	0	0	0	0	0	0	0	0	0	0	0
	Darker	GS2	0	1	0	0	0	0	0	0	0	0	0	0	0	0	0	0	0	0
	↑	↓				↓					↓						↓			
	↓	↓				↓					↓						↓			
	Brighter	GS61	1	0	1	1	1	1	0	0	0	0	0	0	0	0	0	0	0	0
	↓	GS62	0	1	1	1	1	1	0	0	0	0	0	0	0	0	0	0	0	0
	Red	GS63	1	1	1	1	1	1	0	0	0	0	0	0	0	0	0	0	0	0
Gray Scale of Green	Black	GS0	0	0	0	0	0	0	0	0	0	0	0	0	0	0	0	0	0	0
	↑	GS1	0	0	0	0	0	0	1	0	0	0	0	0	0	0	0	0	0	0
	Darker	GS2	0	0	0	0	0	0	0	1	0	0	0	0	0	0	0	0	0	0
	↑	↓				↓														
	↓	↓				↓														
	Brighter	GS61	0	0	0	0	0	0	1	0	1	1	1	1	0	0	0	0	0	0
	↓	GS62	0	0	0	0	0	0	0	1	1	1	1	1	0	0	0	0	0	0
	Green	GS63	0	0	0	0	0	0	1	1	1	1	1	1	0	0	0	0	0	0
Gray Scale of Blue	Black	GS0	0	0	0	0	0	0	0	0	0	0	0	0	0	0	0	0	0	0
	↑	GS1	0	0	0	0	0	0	0	0	0	0	0	0	1	0	0	0	0	0
	Darker	GS2	0	0	0	0	0	0	0	0	0	0	0	0	0	1	0	0	0	0
	↑	↓																		
	↓	↓																		
	Brighter	GS61	0	0	0	0	0	0	0	0	0	0	0	0	1	0	1	1	1	1
	↓	GS62	0	0	0	0	0	0	0	0	0	0	0	0	0	1	1	1	1	1
	Blue	GS63	0	0	0	0	0	0	0	0	0	0	0	0	1	1	1	1	1	1

This specification data sheet is an intellectual property of PowerView Display Corporation. Any copy, reproduction or modification without written permission of PowerView Display Corporation is not allowed.

5.4 Input Timing Chart

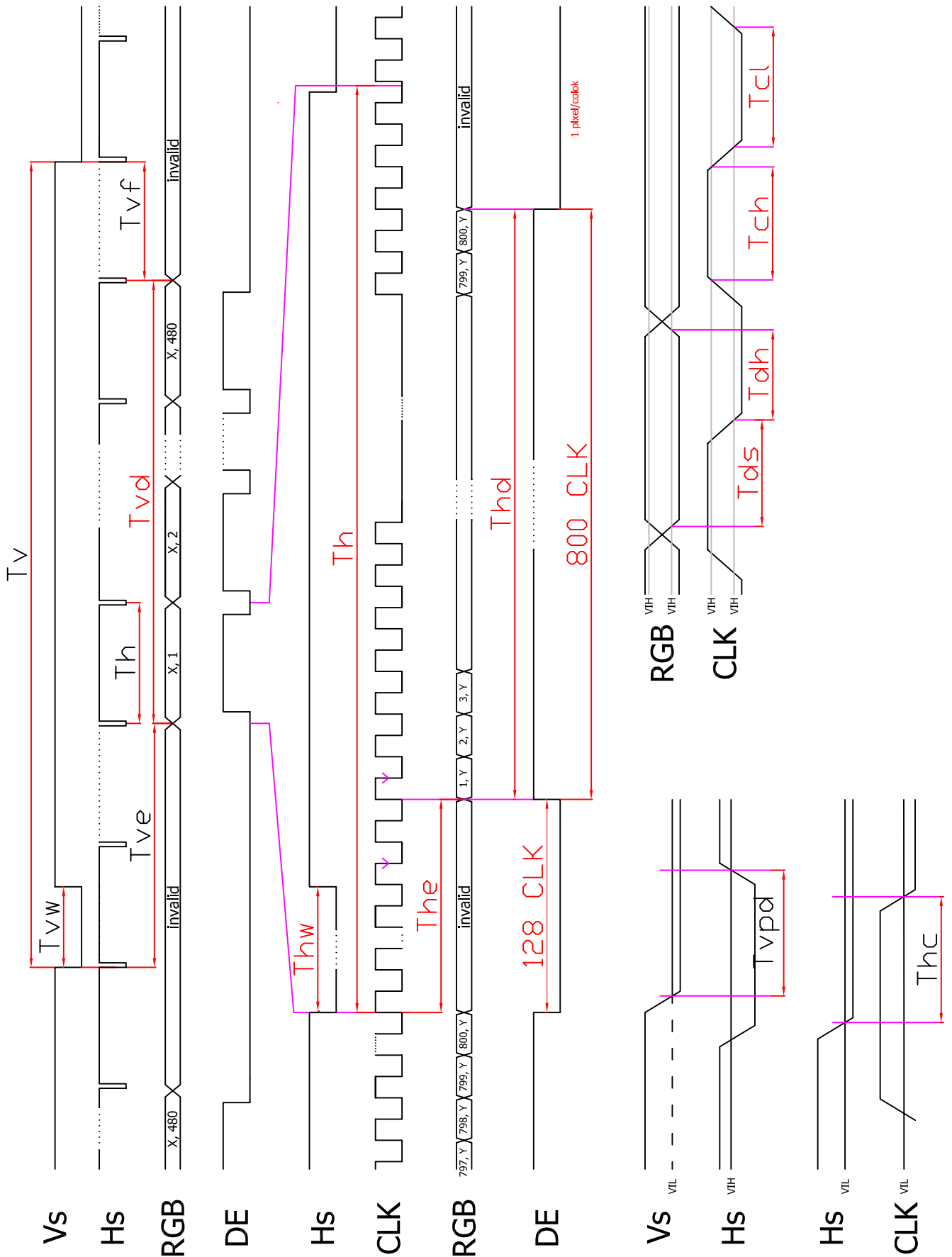



6.0 Pixel Format Image

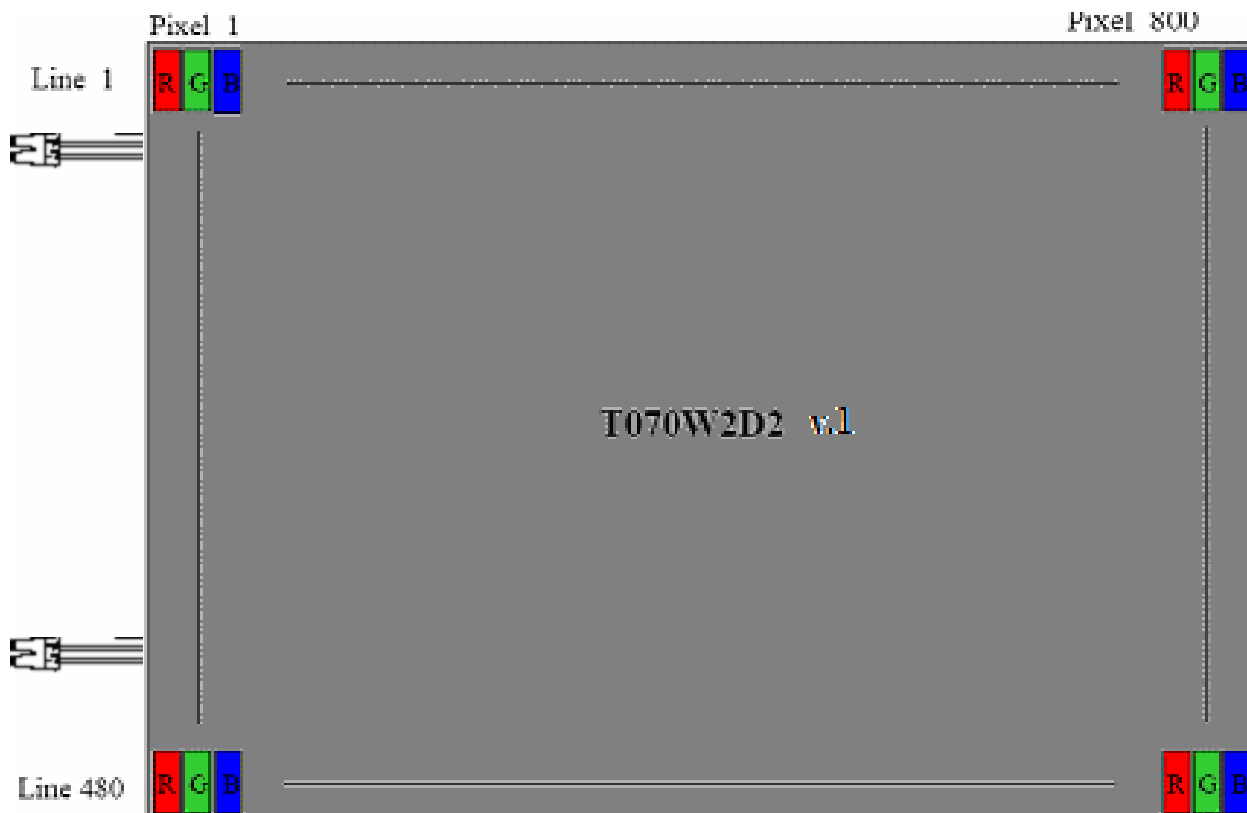

7.0 Display Outline Dimensions

7.1 Monitor Outline Dimensions

- Please refer to the next page

REV	ES. NUMBER	DESCRIPTION	DATE
1	2000002	20000003	

Outline tolerance is 0.3mm

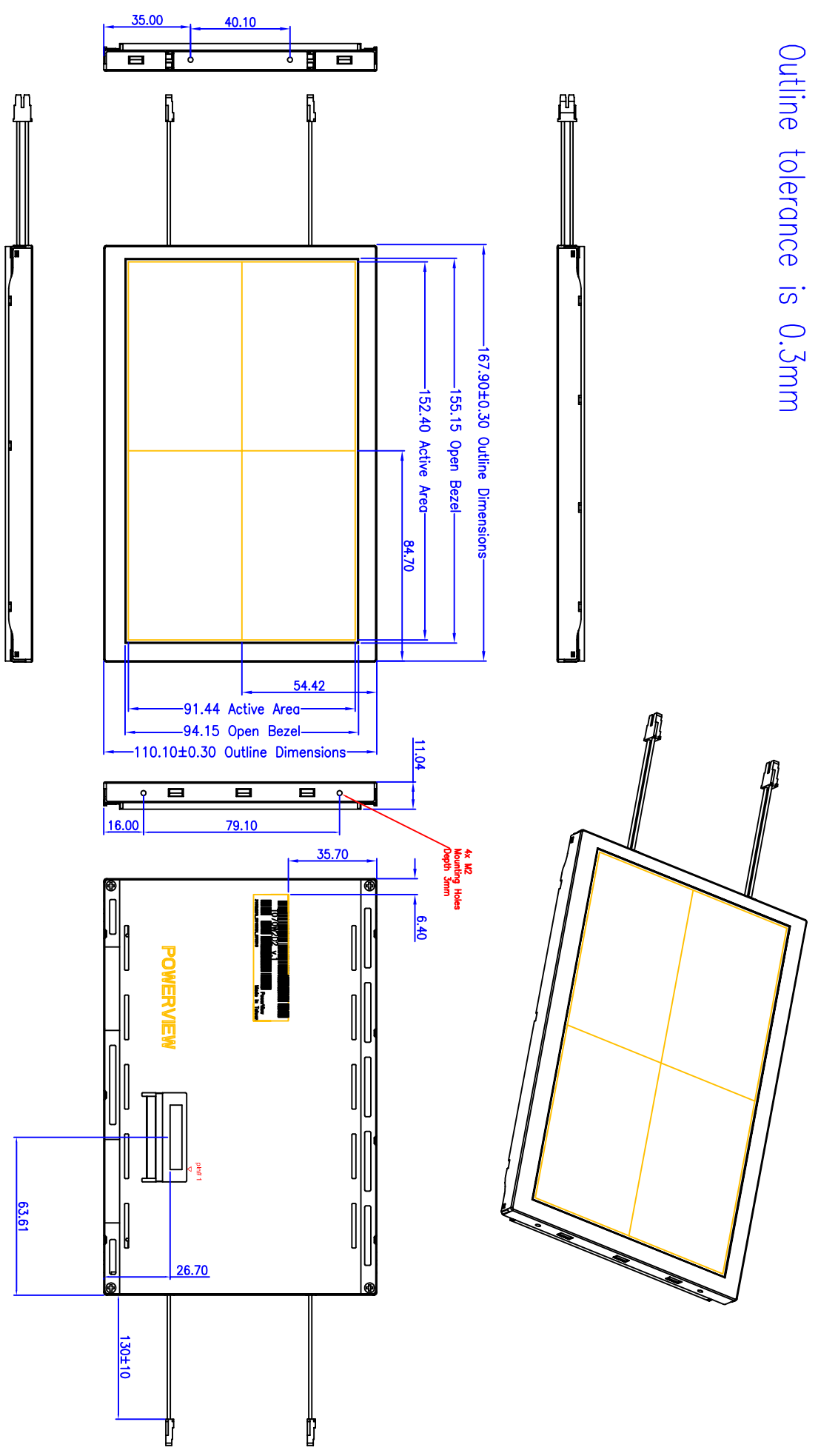

SIZE	1	2	3	4	5	6	7	8	9	10	11	12
8.2 x 8	0.1	0.2	0.3	0.4	0.5	0.6	0.7	0.8	0.9	1.0	1.1	1.2
14.2 x 16	0.1	0.2	0.3	0.4	0.5	0.6	0.7	0.8	0.9	1.0	1.1	1.2
16.2 x 18	0.1	0.2	0.3	0.4	0.5	0.6	0.7	0.8	0.9	1.0	1.1	1.2
18.2 x 20	0.1	0.2	0.3	0.4	0.5	0.6	0.7	0.8	0.9	1.0	1.1	1.2
20.2 x 22	0.1	0.2	0.3	0.4	0.5	0.6	0.7	0.8	0.9	1.0	1.1	1.2
22.2 x 24	0.1	0.2	0.3	0.4	0.5	0.6	0.7	0.8	0.9	1.0	1.1	1.2
24.2 x 26	0.1	0.2	0.3	0.4	0.5	0.6	0.7	0.8	0.9	1.0	1.1	1.2
26.2 x 28	0.1	0.2	0.3	0.4	0.5	0.6	0.7	0.8	0.9	1.0	1.1	1.2
28.2 x 30	0.1	0.2	0.3	0.4	0.5	0.6	0.7	0.8	0.9	1.0	1.1	1.2
30.2 x 32	0.1	0.2	0.3	0.4	0.5	0.6	0.7	0.8	0.9	1.0	1.1	1.2
32.2 x 34	0.1	0.2	0.3	0.4	0.5	0.6	0.7	0.8	0.9	1.0	1.1	1.2
34.2 x 36	0.1	0.2	0.3	0.4	0.5	0.6	0.7	0.8	0.9	1.0	1.1	1.2
36.2 x 38	0.1	0.2	0.3	0.4	0.5	0.6	0.7	0.8	0.9	1.0	1.1	1.2
38.2 x 40	0.1	0.2	0.3	0.4	0.5	0.6	0.7	0.8	0.9	1.0	1.1	1.2
40.2 x 42	0.1	0.2	0.3	0.4	0.5	0.6	0.7	0.8	0.9	1.0	1.1	1.2
42.2 x 44	0.1	0.2	0.3	0.4	0.5	0.6	0.7	0.8	0.9	1.0	1.1	1.2
44.2 x 46	0.1	0.2	0.3	0.4	0.5	0.6	0.7	0.8	0.9	1.0	1.1	1.2
46.2 x 48	0.1	0.2	0.3	0.4	0.5	0.6	0.7	0.8	0.9	1.0	1.1	1.2
48.2 x 50	0.1	0.2	0.3	0.4	0.5	0.6	0.7	0.8	0.9	1.0	1.1	1.2
50.2 x 52	0.1	0.2	0.3	0.4	0.5	0.6	0.7	0.8	0.9	1.0	1.1	1.2
52.2 x 54	0.1	0.2	0.3	0.4	0.5	0.6	0.7	0.8	0.9	1.0	1.1	1.2
54.2 x 56	0.1	0.2	0.3	0.4	0.5	0.6	0.7	0.8	0.9	1.0	1.1	1.2
56.2 x 58	0.1	0.2	0.3	0.4	0.5	0.6	0.7	0.8	0.9	1.0	1.1	1.2
58.2 x 60	0.1	0.2	0.3	0.4	0.5	0.6	0.7	0.8	0.9	1.0	1.1	1.2
60.2 x 62	0.1	0.2	0.3	0.4	0.5	0.6	0.7	0.8	0.9	1.0	1.1	1.2
62.2 x 64	0.1	0.2	0.3	0.4	0.5	0.6	0.7	0.8	0.9	1.0	1.1	1.2
64.2 x 66	0.1	0.2	0.3	0.4	0.5	0.6	0.7	0.8	0.9	1.0	1.1	1.2
66.2 x 68	0.1	0.2	0.3	0.4	0.5	0.6	0.7	0.8	0.9	1.0	1.1	1.2
68.2 x 70	0.1	0.2	0.3	0.4	0.5	0.6	0.7	0.8	0.9	1.0	1.1	1.2
70.2 x 72	0.1	0.2	0.3	0.4	0.5	0.6	0.7	0.8	0.9	1.0	1.1	1.2
72.2 x 74	0.1	0.2	0.3	0.4	0.5	0.6	0.7	0.8	0.9	1.0	1.1	1.2
74.2 x 76	0.1	0.2	0.3	0.4	0.5	0.6	0.7	0.8	0.9	1.0	1.1	1.2
76.2 x 78	0.1	0.2	0.3	0.4	0.5	0.6	0.7	0.8	0.9	1.0	1.1	1.2
78.2 x 80	0.1	0.2	0.3	0.4	0.5	0.6	0.7	0.8	0.9	1.0	1.1	1.2
80.2 x 82	0.1	0.2	0.3	0.4	0.5	0.6	0.7	0.8	0.9	1.0	1.1	1.2
82.2 x 84	0.1	0.2	0.3	0.4	0.5	0.6	0.7	0.8	0.9	1.0	1.1	1.2
84.2 x 86	0.1	0.2	0.3	0.4	0.5	0.6	0.7	0.8	0.9	1.0	1.1	1.2
86.2 x 88	0.1	0.2	0.3	0.4	0.5	0.6	0.7	0.8	0.9	1.0	1.1	1.2
88.2 x 90	0.1	0.2	0.3	0.4	0.5	0.6	0.7	0.8	0.9	1.0	1.1	1.2
90.2 x 92	0.1	0.2	0.3	0.4	0.5	0.6	0.7	0.8	0.9	1.0	1.1	1.2
92.2 x 94	0.1	0.2	0.3	0.4	0.5	0.6	0.7	0.8	0.9	1.0	1.1	1.2
94.2 x 96	0.1	0.2	0.3	0.4	0.5	0.6	0.7	0.8	0.9	1.0	1.1	1.2
96.2 x 98	0.1	0.2	0.3	0.4	0.5	0.6	0.7	0.8	0.9	1.0	1.1	1.2
98.2 x 100	0.1	0.2	0.3	0.4	0.5	0.6	0.7	0.8	0.9	1.0	1.1	1.2
100.2 x 102	0.1	0.2	0.3	0.4	0.5	0.6	0.7	0.8	0.9	1.0	1.1	1.2
102.2 x 104	0.1	0.2	0.3	0.4	0.5	0.6	0.7	0.8	0.9	1.0	1.1	1.2
104.2 x 106	0.1	0.2	0.3	0.4	0.5	0.6	0.7	0.8	0.9	1.0	1.1	1.2
106.2 x 108	0.1	0.2	0.3	0.4	0.5	0.6	0.7	0.8	0.9	1.0	1.1	1.2
108.2 x 110	0.1	0.2	0.3	0.4	0.5	0.6	0.7	0.8	0.9	1.0	1.1	1.2
110.2 x 112	0.1	0.2	0.3	0.4	0.5	0.6	0.7	0.8	0.9	1.0	1.1	1.2
112.2 x 114	0.1	0.2	0.3	0.4	0.5	0.6	0.7	0.8	0.9	1.0	1.1	1.2
114.2 x 116	0.1	0.2	0.3	0.4	0.5	0.6	0.7	0.8	0.9	1.0	1.1	1.2
116.2 x 118	0.1	0.2	0.3	0.4	0.5	0.6	0.7	0.8	0.9	1.0	1.1	1.2
118.2 x 120	0.1	0.2	0.3	0.4	0.5	0.6	0.7	0.8	0.9	1.0	1.1	1.2
120.2 x 122	0.1	0.2	0.3	0.4	0.5	0.6	0.7	0.8	0.9	1.0	1.1	1.2
122.2 x 124	0.1	0.2	0.3	0.4	0.5	0.6	0.7	0.8	0.9	1.0	1.1	1.2
124.2 x 126	0.1	0.2	0.3	0.4	0.5	0.6	0.7	0.8	0.9	1.0	1.1	1.2
126.2 x 128	0.1	0.2	0.3	0.4	0.5	0.6	0.7	0.8	0.9	1.0	1.1	1.2
128.2 x 130	0.1	0.2	0.3	0.4	0.5	0.6	0.7	0.8	0.9	1.0	1.1	1.2
130.2 x 132	0.1	0.2	0.3	0.4	0.5	0.6	0.7	0.8	0.9	1.0	1.1	1.2
132.2 x 134	0.1	0.2	0.3	0.4	0.5	0.6	0.7	0.8	0.9	1.0	1.1	1.2
134.2 x 136	0.1	0.2	0.3	0.4	0.5	0.6	0.7	0.8	0.9	1.0	1.1	1.2
136.2 x 138	0.1	0.2	0.3	0.4	0.5	0.6	0.7	0.8	0.9	1.0	1.1	1.2
138.2 x 140	0.1	0.2	0.3	0.4	0.5	0.6	0.7	0.8	0.9	1.0	1.1	1.2
140.2 x 142	0.1	0.2	0.3	0.4	0.5	0.6	0.7	0.8	0.9	1.0	1.1	1.2
142.2 x 144	0.1	0.2	0.3	0.4	0.5	0.6	0.7	0.8	0.9	1.0	1.1	1.2
144.2 x 146	0.1	0.2	0.3	0.4	0.5	0.6	0.7	0.8	0.9	1.0	1.1	1.2
146.2 x 148	0.1	0.2	0.3	0.4	0.5	0.6	0.7	0.8	0.9	1.0	1.1	1.2
148.2 x 150	0.1	0.2	0.3	0.4	0.5	0.6	0.7	0.8	0.9	1.0	1.1	1.2
150.2 x 152	0.1	0.2	0.3	0.4	0.5	0.6	0.7	0.8	0.9	1.0	1.1	1.2
152.2 x 154	0.1	0.2	0.3	0.4	0.5	0.6	0.7	0.8	0.9	1.0	1.1	1.2
154.2 x 156	0.1	0.2	0.3	0.4	0.5	0.6	0.7	0.8	0.9	1.0	1.1	1.2
156.2 x 158	0.1	0.2	0.3	0.4	0.5	0.6	0.7	0.8	0.9	1.0	1.1	1.2
158.2 x 160	0.1	0.2	0.3	0.4	0.5	0.6	0.7	0.8	0.9	1.0	1.1	1.2
160.2 x 162	0.1	0.2	0.3	0.4	0.5	0.6	0.7	0.8	0.9	1.0	1.1	1.2
162.2 x 164	0.1	0.2	0.3	0.4	0.5	0.6	0.7	0.8	0.9	1.0	1.1	1.2
164.2 x 166	0.1	0.2	0.3	0.4	0.5	0.6	0.7	0.8	0.9	1.0	1.1	1.2
166.2 x 168	0.1	0.2	0.3	0.4	0.5	0.6	0.7	0.8	0.9	1.0	1.1	1.2
168.2 x 170	0.1	0.2	0.3	0.4	0.5	0.6	0.7	0.8	0.9	1.0	1.1	1.2
170.2 x 172	0.1	0.2	0.3	0.4	0.5	0.6	0.7	0.8	0.9	1.0	1.1	1.2
172.2 x 174	0.1	0.2	0.3	0.4	0.5	0.6	0.7	0.8	0.9	1.0	1.1	1.2
174.2 x 176	0.1	0.2	0.3	0.4	0.5	0.6	0.7	0.8	0.9	1.0	1.1	1.2
176.2 x 178	0.1	0.2	0.3	0.4	0.5	0.6	0.7	0.8	0.9	1.0	1.1	1.2
178.2 x 180	0.1	0.2	0.3	0.4	0.5	0.6	0.7	0.8	0.9	1.0	1.1	1.2
180.2 x 182	0.1	0.2	0.3	0.4	0.5	0.6	0.7	0.8	0.9	1.0	1.1	1.2
182.2 x 184	0.1	0.2	0.3	0.4	0.5	0.6	0.7	0.8	0.9	1.0	1.1	1.2
184.2 x 186	0.1	0.2	0.3	0.4	0.5	0.6	0.7	0.8	0.9	1.0	1.1	1.2
186.2 x 188	0.1	0.2	0.3	0.4	0.5	0.6	0.7	0.8	0.9	1.0	1.1	1.2
188.2 x 190	0.1	0.2	0.3	0.4	0.5	0.6	0.7	0.8	0.9	1.0	1.1	1.2
190.2 x 192	0.1	0.2	0.3	0.4	0.5	0.6	0.					

REV	IS NUMBER	DESCRIPTION	DATE
1	XXXXXXXX	XXXXXXXX	

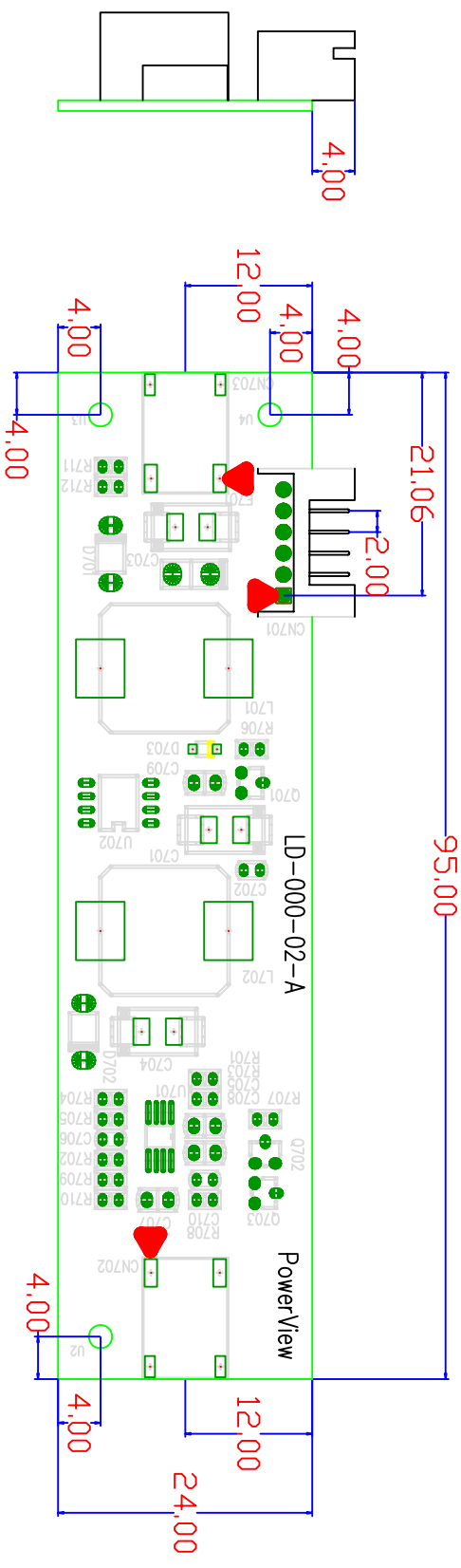

SYMBOL	DESCRIPTION
CN701	

Pin 1	Vin	Power Supply +12V
Pin 2	Vin	Power Supply +12V
Pin 3	ENA	On/Off control (On>+1.8V, Off<+0.8V)
Pin 4	DIM	Linear Dim, 0V(Max.) ~ +1.4V(min.)
Pin 5	GND	Ground
Pin 6	GND	Ground

SYMBOL	DESCRIPTION
CN702 / CN703	

Pin 1	Anode	Anode DC Power Supply for Backlight Unit
Pin 2	Cathod	Cathod DC Power Supply for Backlight Unit

SIZE	QTY	UNIT	REVISION
1.27	1	mm	1
2.54	1	mm	2
5.08	1	mm	3
7.62	1	mm	4
10.16	1	mm	5
12.70	1	mm	6
15.24	1	mm	7
17.78	1	mm	8
20.32	1	mm	9
22.86	1	mm	10
25.40	1	mm	11
27.94	1	mm	12
30.48	1	mm	13
33.02	1	mm	14
35.56	1	mm	15
38.10	1	mm	16
40.64	1	mm	17
43.18	1	mm	18
45.72	1	mm	19
48.26	1	mm	20
50.80	1	mm	21
53.34	1	mm	22
55.88	1	mm	23
58.42	1	mm	24
60.96	1	mm	25
63.50	1	mm	26
66.04	1	mm	27
68.58	1	mm	28
71.12	1	mm	29
73.66	1	mm	30
76.20	1	mm	31
78.74	1	mm	32
81.28	1	mm	33
83.82	1	mm	34
86.36	1	mm	35
88.90	1	mm	36
91.44	1	mm	37
93.98	1	mm	38
96.52	1	mm	39
99.06	1	mm	40
101.60	1	mm	41
104.14	1	mm	42
106.68	1	mm	43
109.22	1	mm	44
111.76	1	mm	45
114.30	1	mm	46
116.84	1	mm	47
119.38	1	mm	48
121.92	1	mm	49
124.46	1	mm	50
127.00	1	mm	51
129.54	1	mm	52
132.08	1	mm	53
134.62	1	mm	54
137.16	1	mm	55
139.70	1	mm	56
142.24	1	mm	57
144.78	1	mm	58
147.32	1	mm	59
149.86	1	mm	60
152.40	1	mm	61
154.94	1	mm	62
157.48	1	mm	63
160.02	1	mm	64
162.56	1	mm	65
165.10	1	mm	66
167.64	1	mm	67
170.18	1	mm	68
172.72	1	mm	69
175.26	1	mm	70
177.80	1	mm	71
180.34	1	mm	72
182.88	1	mm	73
185.42	1	mm	74
187.96	1	mm	75
190.50	1	mm	76
193.04	1	mm	77
195.58	1	mm	78
198.12	1	mm	79
200.66	1	mm	80
203.20	1	mm	81
205.74	1	mm	82
208.28	1	mm	83
210.82	1	mm	84
213.36	1	mm	85
215.90	1	mm	86
218.44	1	mm	87
220.98	1	mm	88
223.52	1	mm	89
226.06	1	mm	90
228.60	1	mm	91
231.14	1	mm	92
233.68	1	mm	93
236.22	1	mm	94
238.76	1	mm	95
241.30	1	mm	96
243.84	1	mm	97
246.38	1	mm	98
248.92	1	mm	99
251.46	1	mm	100

MATERIAL		FINISH		APPROVED		CHECKED		REVISIONS	
See notes	See notes	See notes	See notes	See notes	See notes	See notes	See notes	See notes	See notes
POVERVIEW DISPLAY CORPORATION		All Rights Reserved		LD070W2D2V1		H Power LED Driver for TORNAZD v.1		0807/1/18	
PART NUMBER		REV		DATE		DRAWN		DATE	
08072620070-01		A3		1-2		A			



8.0 Labeling, Packaging & Others

* Labeling

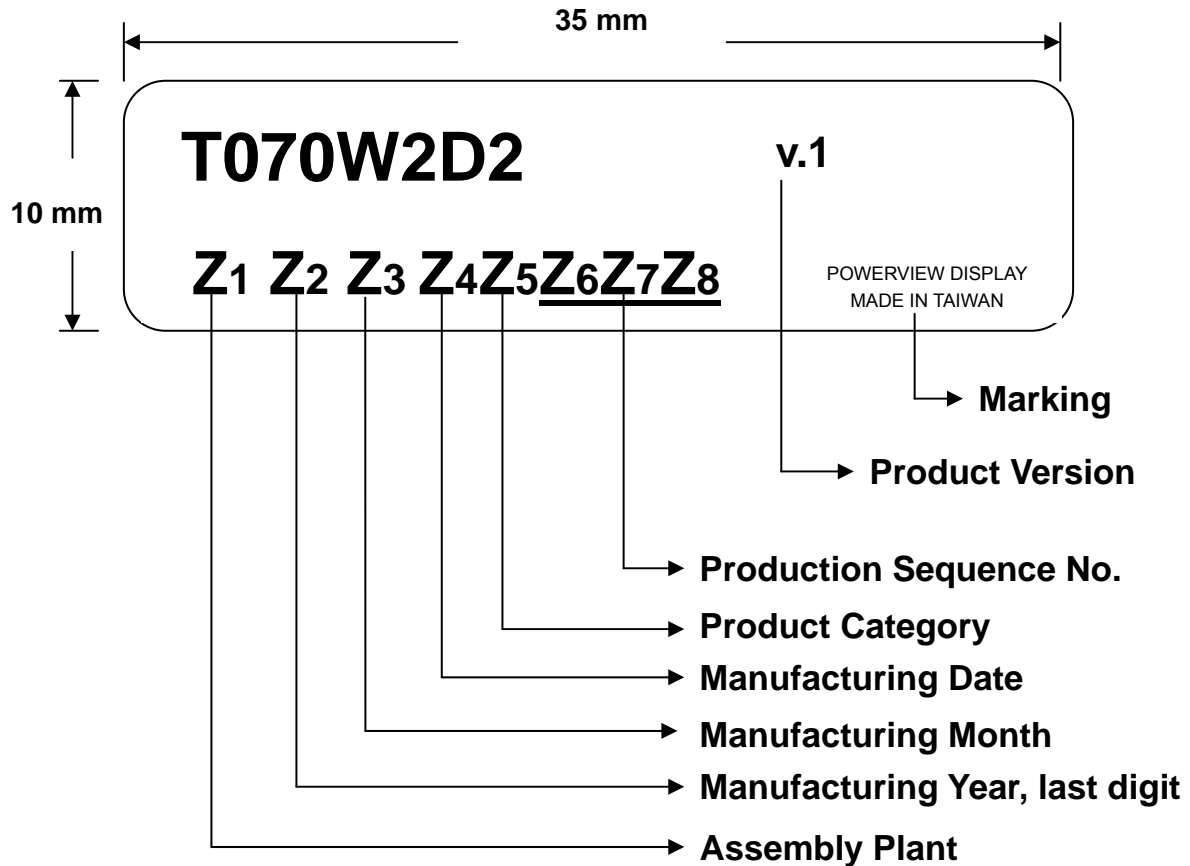

* Packaging

- Please refer to the next page

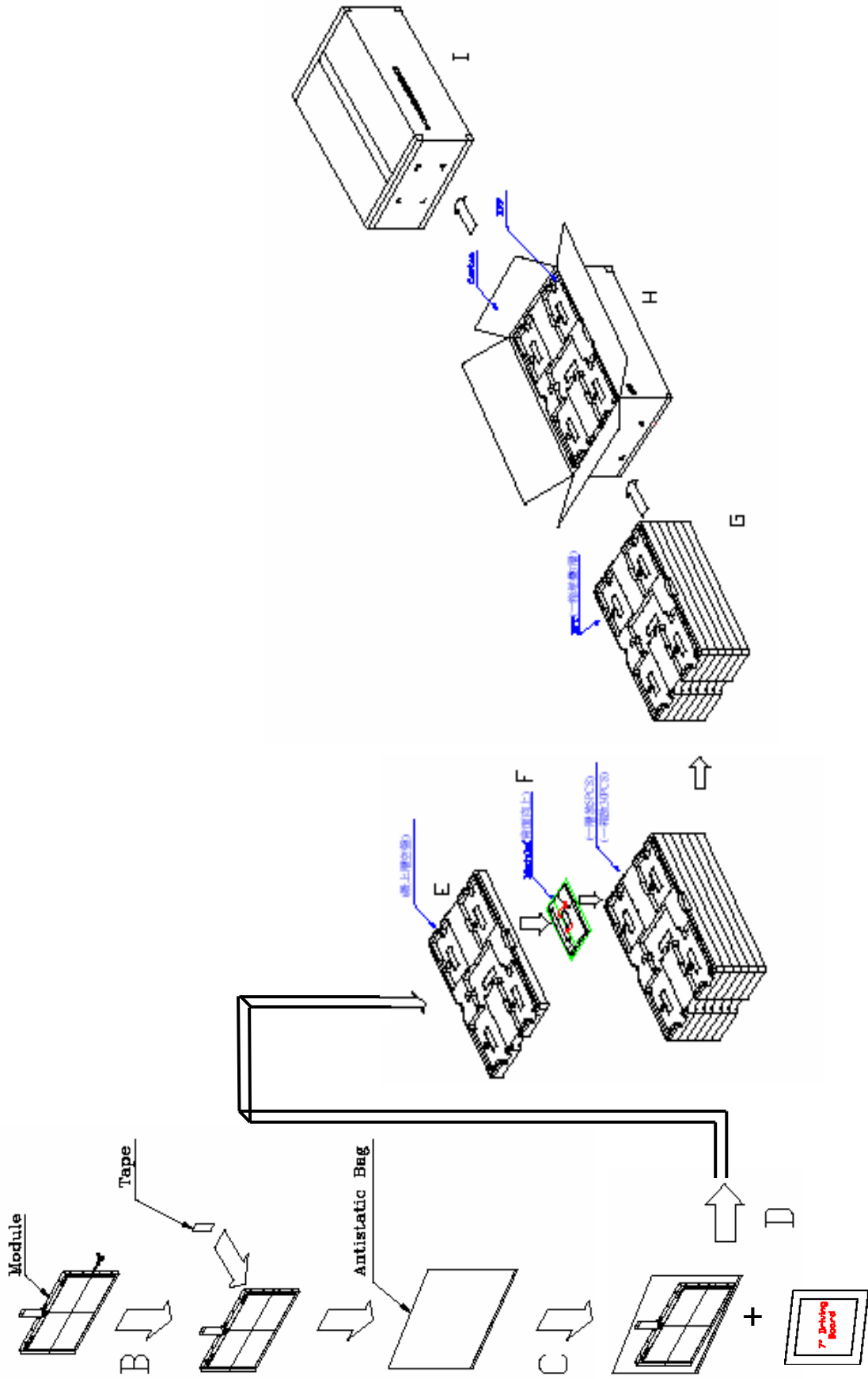



9.0 General Notice

9.1 Reliability Test Items (Note 2)

No.	Test Items	Conditions	Remark
1	High Temperature Storage	Ta= + 80°C 240 Hrs	Note 1
2	Low Temperature Storage	Ta= - 30°C 240 Hrs	
3	High Temperature Operation	Ta= + 70°C 240 Hrs	
4	Low Temperature Operation	Ta= - 30°C 240 Hrs	
5	High Temperature and High Humidity	Tp= 60°C, 90%RH 240 Hrs	operation
6	Heat Shock	-25~80°C/200 cycles 1Hr/cycle	Non-operation
7	Electrostatic discharge	±200V, 200pF(0Ω), once for each terminal	Non-operation
8	Vibration	Frequency range : 8~33.3 Hz Stoke : 1.3mm Sweep : 2.9G, 33.3~400Hz Cycle : 15 minutes 2 hours for each direction of X,Z 4 hours for Y direction	JIS C7021, A-10 Condition A
9	Mechanical Shock	100G, 6ms, ±X±Y±Z 3 times for each direction	JIS C7021, A-7 Condition C
10	Vibration (with carton)	Random vibration : 0.015G ² /Hz from 5~200Hz -6dB/octave from 200~500Hz	IEC 68-34
11	Drop (with carton)	Height : 60 cm 1 corner, 3 edges, 6 surfaces	JIS Z0202

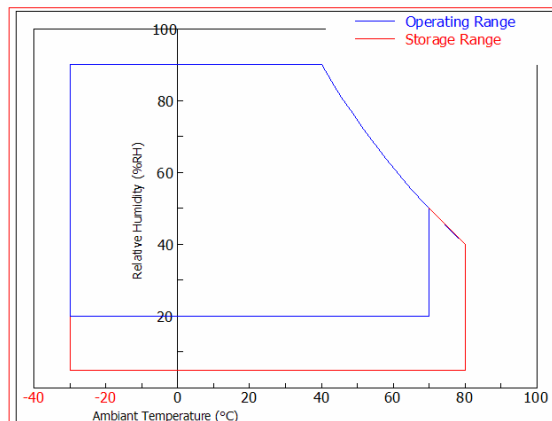

Note1: Ta: Ambient temperature.

Note 2: In the standard conditions, there is not display function NG issue occurred. All the cosmetic specification is judged before the reliability stress.



10.2 Storage, Operation & Others

- (a) Do not leave the panel in high temperature, and high humidity for a long time.
It is highly recommended to store the module with temperature from 0 to 35°C and relative humidity of less than 70%.
- (b) Do not store the TFT-LCD module in direct sunlight.
- (c) The module shall be stored in a dark place. It is prohibited to apply sunlight or fluorescent light during the store.
- (d) Do not connect, disconnect the module in the "Power On" condition.
- (e) Power supply should always be turned on/off by the item 3.2 "Electrical Absolute Ratings"
- (f) The liquid-crystal is deteriorated by ultraviolet rays. Do not leave it in direct sunlight and strong ultraviolet rays for many hours.
- (g) Avoid condensation of water. It may result in improper operation or disconnection of electrode.
- (h) Do not exceed the absolute maximum rating value. (the supply voltage variation, input voltage variation, variation in part contents and environmental temperature, and so on)
Otherwise the panel may be damaged.
- (i) If the panel displays the same pattern continuously for a long period of time, it can be the situation when the image "Sticks" to the screen.
- (j) This panel has its circuitry FPC on the bottom side and should be handled carefully in order not to be stressed.