



TFT-LCD MONITOR

Product Information

Temporary

MODEL NO. : T055V1D1

Date : 2008.01.11 Revision E2.2

Prepared by : Jason Cheng

Jason Cheng, Engineer, Product Development Div.

Approved by : Kelvin Hsieh

Kelvin Hsieh, Senior Engineer, Product Development Div.

Note :

This TFT LCD Monitor is distributed by:



Display Solution AG
Talhofstraße 32a
D-82205 Gilching
GERMANY
Fon +49 (0)8105 / 73 403 - 0
Fax +49 (0)8105 / 73 403 - 79
E-Mail: info@display-solution.com
Internet: www.display-solution.com

This product specification is subject to change without any notice.



Records of Revision

Date	Rev. No.	Summary	Page
2006.11.26	Temp.1.0	Temp. Release	1
2007.03.26	Temp.2.0	1.f _H Value updated to 31.475 kHz	8
		2. Viewing Angle Data Revised	8
		3. Add the LED backlight life time	8
		4. Correct the part number of input connector	11
		5. Correct the pin assignment on 5.3.1	11/12
		6. Add the control mode of LED driver	12/13
		7. Correct the AC timing parameters on 5.1	10
		8. Modify the timing chart on 5.4	15
		9. Add the drawing of mechanical outline	17
2007.6.7	Temp.E2.1	2.3.2 Mechanical Dimensions Revised	6
		1. Pin 38: GND Pin39:CLK inversed → Pin38:CLK Pin39:GND	12
		9.1 Reliability Test Items - Low Temperature Operation/Storage Data Revised	20
2008.1.11	Temp.E2.2	4.0 Note(1) revised	8
		5.2.2 Note 1 added	11
		5.3.2 Revise the control mode of LED Driver	12/13



Contents		Page
1.0 Handling Precautions	-----	4
2.0 General Description	-----	5
2.1 General Application	----- 5	
2.2 Main Features	----- 5	
2.3 General Information	----- 5	
2.3.1 Display Characteristics	----- 5	
2.3.2 Mechanical Dimensions	----- 6	
3.0 Absolute Maximum Ratings	-----	6
3.1 Absolute Ratings of Environment Requirement	----- 6	
3.2 Electrical Absolute Ratings	----- 6	
3.2.1 TFT-LCD Module	----- 7	
3.2.2 Backlight Module(LED)	----- 7	
4.0 Optical Characteristics	-----	8
5.0 Electrical Characteristics	-----	10
5.1 AC Timing Characteristics	----- 10	
5.2 DC Characteristics	----- 10	
5.2.1 TFT-LCD Module	----- 10	
5.2.2 Backlight Unit & LED Driver	----- 11	
5.3 Input Terminal Pin Assignment	----- 11	
5.3.1 Signal Input Interface	----- 11	
5.3.2 LED Driver Unit	----- 12	
5.3.3 Scanning Direction	----- 13	
5.3.4 Color Data Reference	----- 13	
5.4 Input Timing Chart	----- 15	
6.0 Pixel Format Image	-----	16
7.0 Display Outline Dimensions	-----	16
8.0 Labeling, Packaging & Others	-----	18
9.0 General Notices	-----	20
9.1 Reliability Test Item	----- 20	
9.2 Storage, Operation & Others	----- 21	



1.0 Handling Precaution

- 1.) Handle with care. Pay attention not to press or scratch the surface of the monitor, especially the polarizer. Do not twist or bend the monitor. It may cause un-recoverable damage.
- 2.) Do not drop or bump the monitor since this monitor contains fragile glass components. Breakage of this monitor might cause leakage of the liquid crystal sealed inside the glasses. Do not touch the liquid crystal liquid in case of leakage. **Flush with massive water immediately in case of contact with your skin by liquid crystal fluid and call for doctor for immediate medical treatment.**
- 3.) Be sure to turn off power supply while plug or un-plug the power input connector.
- 4.) Clean up the polarizer only with soft solvent if necessary. The desirable cleaners are water, IPA(Isopropyl Alcohol) or Hexane. Do not use Ketone type materials (ex. Acetone), Ethyl alcohol, toluene, Ethyl acid or Methyl chloride. It will permanently damage the polarizer due to chemical reaction. 5.) Wipe off fluid drop immediately to prevent from possible discoloration or spots on the polarizer.
- 6.) Do not twist nor bend the monitor structure, even momentarily. Bending or twisting torque may likely damage the internal components of the monitor.
- 7.) The cold cathode fluorescent lamp in LCD contains small amount of mercury (Hg). Please refer to the design specification for application and the local regulations and environmental laws for disposal purpose.
- 8.) Protect the monitor from static environment to prevent from damage to the CMOS gate array IC.



2.0 General Description

T055V1D1 is a 5.55 inch (4:3 aspect ratio) color active matrix TFT LCD monitor with excellent display performance driven by a pure **DIGITAL** CMOS interface assembled in a compact and slim sunlight readable LED backlight unit. This LCD supports 640(H) x RGB x 480(V) stripe color pixel format and 262,144 colors (RGB 6 bits data) with vivid color image. Its outstanding performances with wide operation temperature range, **-30 ~ 70°C**, high brightness, **400 nits(typ.)**, wide viewing angle(140°/120°) and high contrast ratio 500:1, make this monitor very suitable for applications under severe environments or outdoor use.

2.1 General Applications

- Display terminal for applications of Car Navigation, Industrial, Medical, Gaming, Amusement, Advertisement and more

2.2 Main Features

- Ultra Slim boarder
- 5.5" 640xRGBx480 Resolution with 4:3 Display Aspect Ratio
- LED Backlight
- Excellent Brightness at low temperature
- Low Power Consumption
- High Brightness
- Wide Viewing Angle
- High Contrast Ratio
- Wide Temperature Range
- Pure Digital CMOS TTL Interface
- DE (Data Enable) Mode/HV Mode selectable
- Thin and Light Weight
- LED Driver built-in
- RoHS Compliance

2.3 General Information

2.3.1 Display Characteristics

Item	Specification	Unit	Note
Display Area (HxV)	112.9 x 84.7	mm	5.55" diagonal
Driver Element	a-Si TFT Active Matrix	-	-
Number of Pixels (HxV)	640 RGBx 480	pixel	Std. 4:3
Pixel Arrangement	R.G.B Vertical Stripe	-	-
Dot Pitch (HxV)	0.0588 x 0.1764	mm	Dot



Viewing Angle (H/V)	140/120	degree	6 o'clock
Signal Interface	Digital RGB 18 bits		262K colors
Display Mode	Normally White	-	-

2.3.2 Mechanical Dimensions

Item		Min.	Typ.	Max.	Unit	Note
Dimension	Horizontal		125.5		mm	±0.5 mm
	Vertical		101.4			±0.5 mm
	Depth	-	8.82			+0.5 mm
Weight			TBD		g	±10 g

3.0 Absolute Maximum Ratings

3.1 Absolute Ratings of Environment Requirement

Item	Symbol	Min.	Max.	Unit	Note
Storage Temperature	Tstg	-30	85	°C	
Operation Temperature (Ambient Temperature)	Top	-30	70	°C	

Note (1) Temperature and relative humidity range are shown in the figure below.

95% RH Max. ($40^{\circ}\text{C} > T_a$)

Maximum wet – bulb temperature at 39°C or less. ($T_a > 40^{\circ}\text{C}$) No condensation.

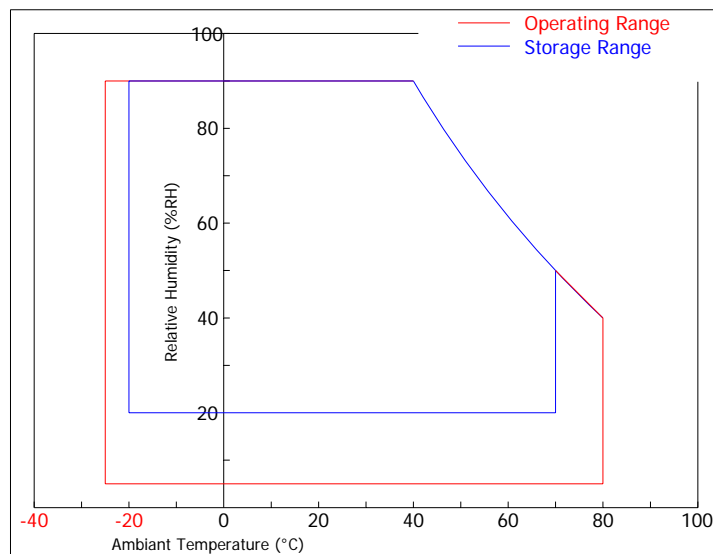



3.2 Electrical Absolute Ratings

3.2.1 TFT-LCD Module

(Ta=25±2°C), Vgg=GND=0V)

Item	SYMBOL	Min.	Max.	UNIT	NOTE
Power Supply Voltage	V _{DD}	-0.3	4.0	V	(1),(2)
Input Voltage	V _{i1}	-0.3	V _{DD} + 0.3	V	(1),(2)

3.2.2 Backlight Module(LED)

Item	SYMBOL	MIN	MAX	UNIT	NOTE
Input DC Voltage	V _{BL}	-	15	V	(1),(2)

Note (1) Within operating temperature

Note (2) Permanent damage to the device may occur if maximum values are exceeded.

Functional operation should be restricted to the conditions described under normal operating conditions.



4.0 Optical Characteristics

The following items are measured under stable conditions in a dark room or equivalent state.

* Measuring Equipment: BM-5A, PR-650

($V_{DD}=3.3V$, $f_V=60Hz$, $f_H=31.475KHz$, $T_a=25\pm 2^\circ C$)

Item	Symbol	Condition	Min.	Typ.	Max.	Unit	Note
Contrast Ratio	CR	At optimized Viewing Angle		500	-	-	(1)(2) (4)
Response Time at 25°C	Rising	$\theta=0^\circ$	-	15		ms	(3)
	Falling		-	10			
Luminance	Y_L	$V_{Dim}=V_{max}$, 25°C		400	-	cd/m ²	(1)(2) (6)
Color Chromaticity (CIE 1931)	White	W_X	$\theta=0^\circ$		TBD	-	(2)(6)
		W_Y	$\theta=0^\circ$		TBD	-	
Viewing Angle	Hor.	θ_L	CR \geq 10 at center point		70	-	Degree (2)(5)
		θ_R			70	-	
	Ver.	θ_H			50	-	
		θ_L			70	-	
Brightness Endurance	+25°C	-	Continuous Operation	40,000	50,000	-	hour (7)

Note (1) : Ambient temperature =25°C, and , using the Mode 2 of LED control scheme and $V_{DIM}=0V$ to get the maximum brightness. To be measured in the dark room.

Note (2) : To be measured on the center area of panel with a viewing cone of 1° by Topcon Luminance Meter BM-5, after 10 minutes operation.

Note (3) : Definition of response time:

The output signals of photo detector are measured when the input signals are changed from “black” to “white”(falling time) and from “white” to “black”(rising time), respectively.

The response time is defined as the time interval between the 10% and 90% of amplitudes. Refer to figure as below.

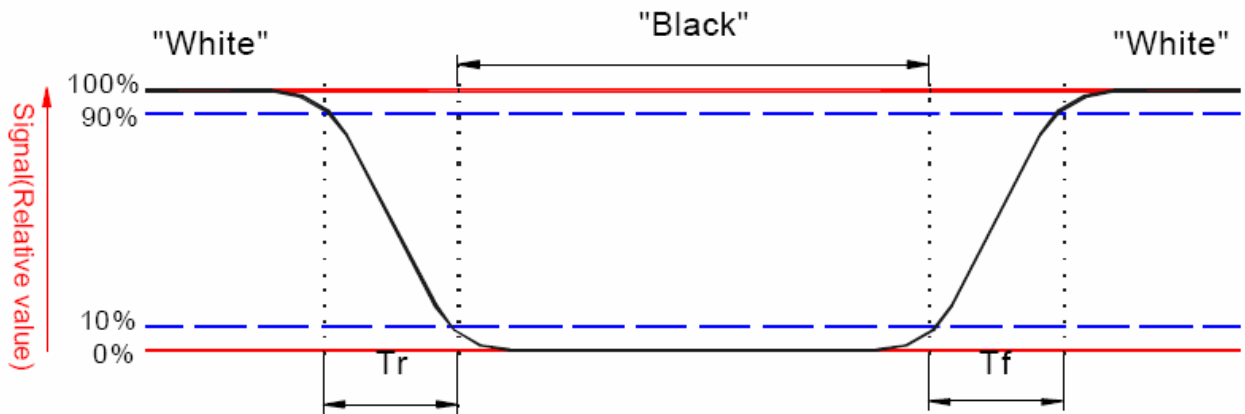

Note (4) : Definition of contrast ratio:

Contrast ratio is calculated with the following formula.

$$\text{Contrast ratio (CR)} = \frac{\text{Photo detector output when LCD is at "White" state}}{\text{Photo detector output when LCD is at "Black" state}}$$

Note (5) : Definition of viewing angle, Refer to figure as below.

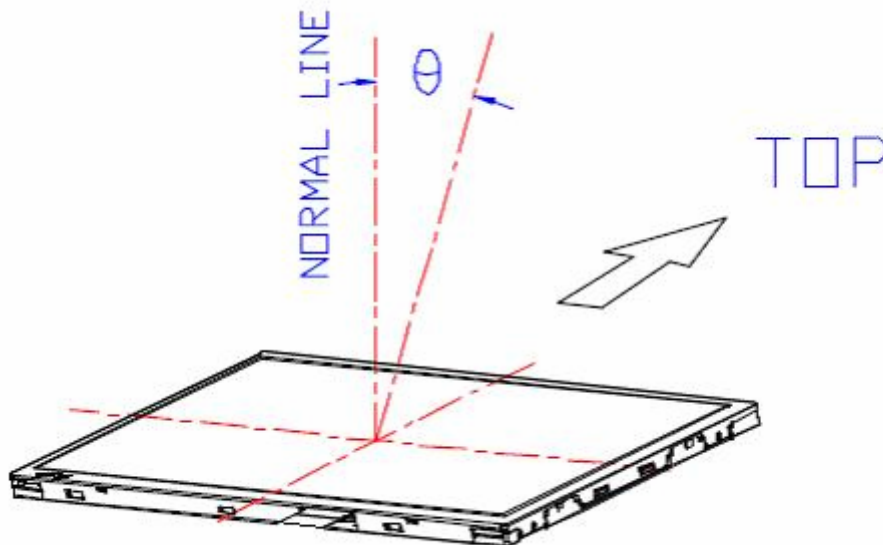

Note (6) : Measured at the center area of the panel when all the input terminals of LCD panel are electrically opened.

Note (6) : Continuous operation time which doesn't deteriorate the brightness under 50% of the brightness at the beginning measured at room temperature at full brightness.



5.0 Electrical Characteristics

5.1 AC Timing Characteristics

Item	Symbol	Min.	Typ.	Max.	Unit	Note
Clock Frequency	F_{ck}		25.18	30	MHz	
	T_{ck}	33.3	39.7		ns	
Clock Duty Ratio	$T_{ch}/(T_{ch}+T_{cl})$	40	50	60	%	
Horizontal Display	T_h		800		clk	
	T_{hd}	640	640	640	clk	
	T_{hw}		10		clk	
	T_{he}	-	TBD		clk	
Vertical Display	Frame Rate		60		Hz	
	T_v		525		T_h	
	T_{vd}	480	480	480	T_h	
	T_{vw}		2		T_h	
	T_{ve}		TBD		T_h	
Data Setup Time	T_{ds}	12	-	-	ns	
Data Hold Time	T_{dh}	12	-	-	ns	
DE Setup Time	T_{es}	12	-	-	ns	
Hs to CLK difference	T_{hc}	12		$T_{ck} - 12$	ns	
Vs to Hs difference	T_{vpd}	12		$T_h - T_{hw}$	ns	

5.2 DC Characteristics

5.2.1 TFT-LCD Module

Item	Symbol	Min.	Typ.	Max.	Unit	Note
Power Supply	V_{DD}	3.0	3.3	5.25	V	(1)
Permissive Input Ripple Voltage	V_{RF}	-	-	100	mV _{P-P}	
Power Supply Current	I_{DD}	-	(220)	-	mA	$V_{DD}=3.3V$
Logic Input Voltage	V_{IL}	0	-	$0.3 V_{DD}$	V	(2)
	V_{IH}	$0.7 V_{DD}$	-	V_{DD}	V	(2)

Note (1) VDD Power-On Condition :

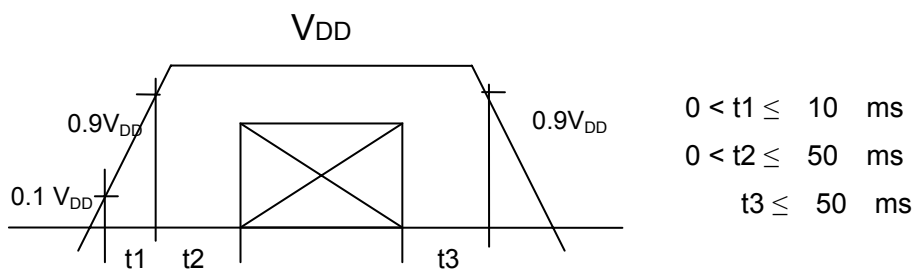

Note (2) CLK, Hsync, Vsync, DE, R0~R5, G0~G5, B0~B5



5.2.2 Backlight Unit & LED Driver

Item	Symbol	Min.	Typ.	Max.	Unit	Note
Power Supply	V _{BL}	10.8	12	13.2	V	
	I _{BL}		(0.16)		Amp	V _{BL} = 12V

Note 1 : V_{BL} = 12V, using the Mode 2 of LED control scheme and V_{DIM} = 0V to get the maximum brightness.

5.3 Input Terminal Pin Assignment

5.3.1 Signal Input Interface CN201

Kyocera Elco CN : 40 FFC/FPC Type : 08-6210-040-340-800

Pin No	Symbol	Description	Remark
1	GND	Ground	-
2	GND	Ground	-
3	VS	Vertical Sync	-
4	V _{DD}	Power Supply for Logic (+3.3V)	-
5	V _{DD}	Power Supply for Logic (+3.3V)	-
6	V _{DD}	Power Supply for Logic (+3.3V)	-
7	V _{DD}	Power Supply for Logic (+3.3V)	-
8	Hs	Horizontal Sync	-
9	DE	Data Enable	-
10	LR	Horizontal Scanning Direction Control	Note 1
11	UD	Vertical Scanning Direction Control	Note 2
12	Mode	DE/HV Mode Control	Note 3
13	B5	Blue Data (MSB)	-
14	B4	Blue Data	-
15	B3	Blue Data	-
16	GND	Ground	-
17	B2	Blue Data	-
18	B1	Blue Data	-
19	B0	Blue Data (LSB)	-
20	GND	Ground	-
21	G5	Green Data (MSB)	-
22	G4	Green Data	-
23	G3	Green Data	-
24	GND	Ground	-
25	G2	Green Data	-
26	G1	Green Data	-
27	G0	Green Data (LSB)	-
28	GND	Ground	-



29	R5	Red Data (MSB)	-
30	R4	Red Data	-
31	R3	Red Data	
32	GND	Ground	
33	R2	Red Data	
34	R1	Red Data	
35	R0	Red Data (LSB)	
36	GND	Ground	
37	GND	Ground	
38	CLK	Data Clock	
39	GND	Ground	
40	GND	Ground	

Note 1: Normal scanning: Set “high” to LR pin.

Note 2: Normal Scanning: Set “low” to UD pin

Note 3: DE mode: Set “high” to Mode pin, HV mode: Set “Low” to Mode pin

5.3.2 LED Driver Unit CN101

Connector : DF13-5P-1.25DSA20

Mode 1

Matching Connector : DF13-5S-1.25(xx)

Pin No.	Symbol	Description	Remark
1	V _{BL}	Power Supply for LED Driver	
2	EN	LED Enable & Dimming Control Input	Note 1
3	DIM	Connect this pin to GND at this mode	Note 2
4	GND	Ground Pin for LED Driver	
5	GND	Ground Pin for LED Driver	

Note 1 : The “Enable & Dimming Control” of the LED driver shares the same pinning.

The LED backlight will turn on when the input voltage of this pin exceeds +0.6V.

The LED current/brightness will be adjustable by applying an analog voltage between +0.8 ~ +1.4V(Max. Brightness).

Note 2: The “DIM” pin should be connected to GND in order to get the full brightness.

Mode 2:

Pin No.	Symbol	Description	Remark
1	V _{BL}	Power Supply for LED Driver	
2	EN	LED Enable Control Input	Note 1
3	DIM	Dimming Control Input	Note 2
4	GND	Ground Pin for LED Driver	
5	GND	Ground Pin for LED Driver	

Note 1 : Disable V_{EN}<0.6 V, Enable V_{EN}>1.8 V



Note 2 : Max Brightness $V_{DIM} : 0V$, Min Brightness $V_{DIM} : 2.2V$ (≈ 0 Nit)

Mode 3:

Pin No.	Symbol	Description	Remark
1	V_{BL}	Power Supply for LED Driver	
2	EN	PWM Control Pulse Input	Note 1, 2
3	DIM	Connect this pin to GND at this mode	Note 3
4	GND	Ground Pin for LED Driver	
5	GND	Ground Pin for LED Driver	

Note 1: Valley of PWM Pulse $V_{PVM} < 0.6 V$, Peak of PWM Pulse $V_{PVM} > 1.8 V$

Note 2: The frequency of each completed PWM cycle: 100~300 Hz

Note 3: The "DIM" pin should be connected to GND in order to get the full brightness.

5.3.3 Scanning Direction

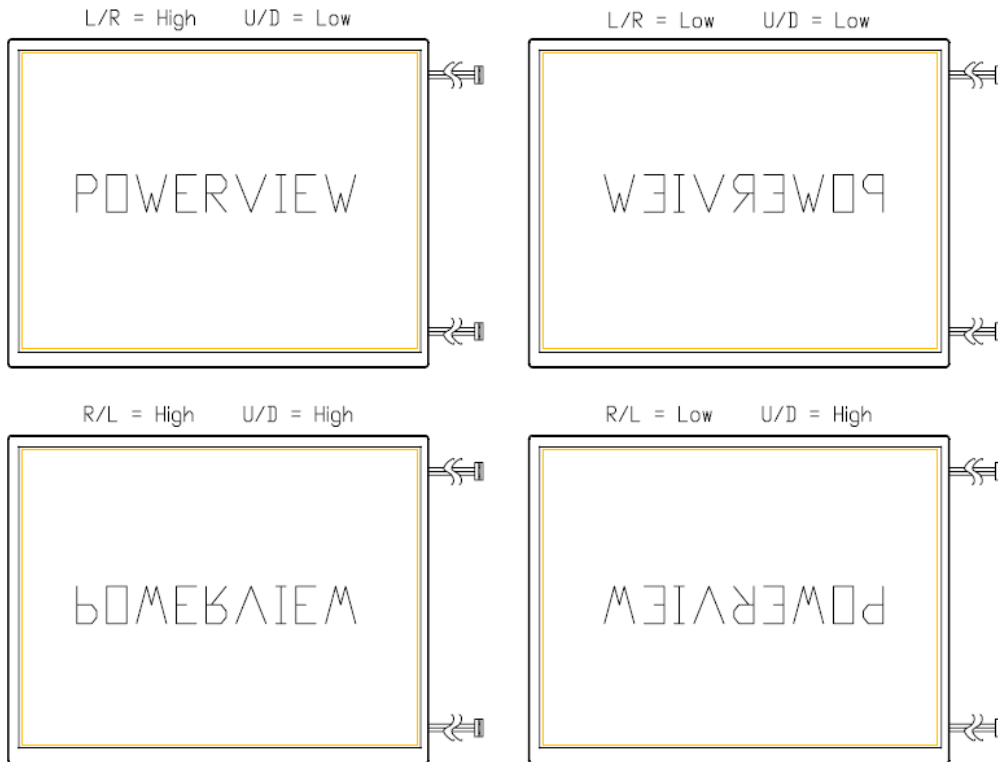

5.3.4 Color Data Reference

The below table is about nput signal, Basic display colors and gray scale of each color.

0 : Low Level Voltage 1 : High Level Voltage

Each basic color can be displayed in 64 gray scales from 6 bit data signals. With the combination of total 18 bit data signals, the 262,144 color display can be achieved on the screen.

- Please refer to the next page



	Colors & Gray Scale	Data Signal																		
		Gray Scale	R0	R1	R2	R3	R4	R5	G0	G1	G2	G3	G4	G5	B0	B1	B2	B3	B4	B5
Basic Color	Black	-	0	0	0	0	0	0	0	0	0	0	0	0	0	0	0	0	0	0
	Blue	-	0	0	0	0	0	0	0	0	0	0	0	0	1	1	1	1	1	1
	Green	-	0	0	0	0	0	0	1	1	1	1	1	1	0	0	0	0	0	0
	Cyan	-	0	0	0	0	0	0	1	1	1	1	1	1	1	1	1	1	1	1
	Red	-	1	1	1	1	1	1	0	0	0	0	0	0	0	0	0	0	0	0
	Magenta	-	1	1	1	1	1	1	0	0	0	0	0	0	1	1	1	1	1	1
	Yellow	-	1	1	1	1	1	1	1	1	1	1	1	1	0	0	0	0	0	0
	White	-	1	1	1	1	1	1	1	1	1	1	1	1	1	1	1	1	1	1
Gray Scale of Red	Black	GS0	0	0	0	0	0	0	0	0	0	0	0	0	0	0	0	0	0	0
	↑	GS1	1	0	0	0	0	0	0	0	0	0	0	0	0	0	0	0	0	0
	Darker	GS2	0	1	0	0	0	0	0	0	0	0	0	0	0	0	0	0	0	0
	↑	↓				↓					↓						↓			
	↓	↓									↓						↓			
	Brighter	GS61	1	0	1	1	1	1	0	0	0	0	0	0	0	0	0	0	0	0
	↓	GS62	0	1	1	1	1	1	0	0	0	0	0	0	0	0	0	0	0	0
	Red	GS63	1	1	1	1	1	1	0	0	0	0	0	0	0	0	0	0	0	0
Gray Scale of Green	Black	GS0	0	0	0	0	0	0	0	0	0	0	0	0	0	0	0	0	0	0
	↑	GS1	0	0	0	0	0	0	1	0	0	0	0	0	0	0	0	0	0	0
	Darker	GS2	0	0	0	0	0	0	0	1	0	0	0	0	0	0	0	0	0	0
	↑	↓				↓														
	↓	↓				↓														
	Brighter	GS61	0	0	0	0	0	0	1	0	1	1	1	1	0	0	0	0	0	0
	↓	GS62	0	0	0	0	0	0	0	1	1	1	1	1	0	0	0	0	0	0
	Green	GS63	0	0	0	0	0	0	1	1	1	1	1	1	0	0	0	0	0	0
Gray Scale of Blue	Black	GS0	0	0	0	0	0	0	0	0	0	0	0	0	0	0	0	0	0	0
	↑	GS1	0	0	0	0	0	0	0	0	0	0	0	0	1	0	0	0	0	0
	Darker	GS2	0	0	0	0	0	0	0	0	0	0	0	0	0	1	0	0	0	0
	↑	↓																		
	↓	↓																		
	Brighter	GS61	0	0	0	0	0	0	0	0	0	0	0	0	1	0	1	1	1	1
	↓	GS62	0	0	0	0	0	0	0	0	0	0	0	0	0	1	1	1	1	1
	Blue	GS63	0	0	0	0	0	0	0	0	0	0	0	0	1	1	1	1	1	1

5.4 Input Timing Chart

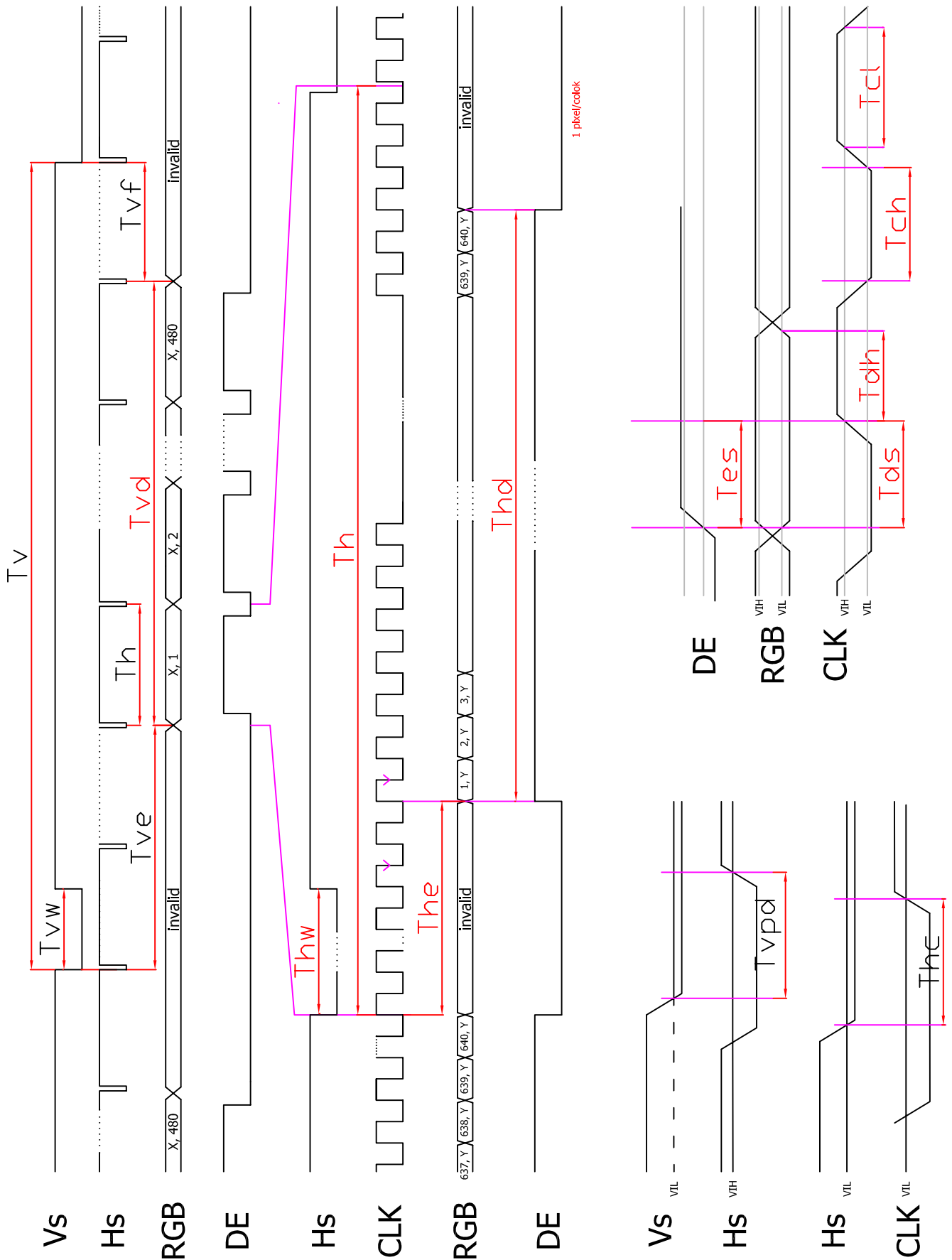



6.0 Pixel Format Image

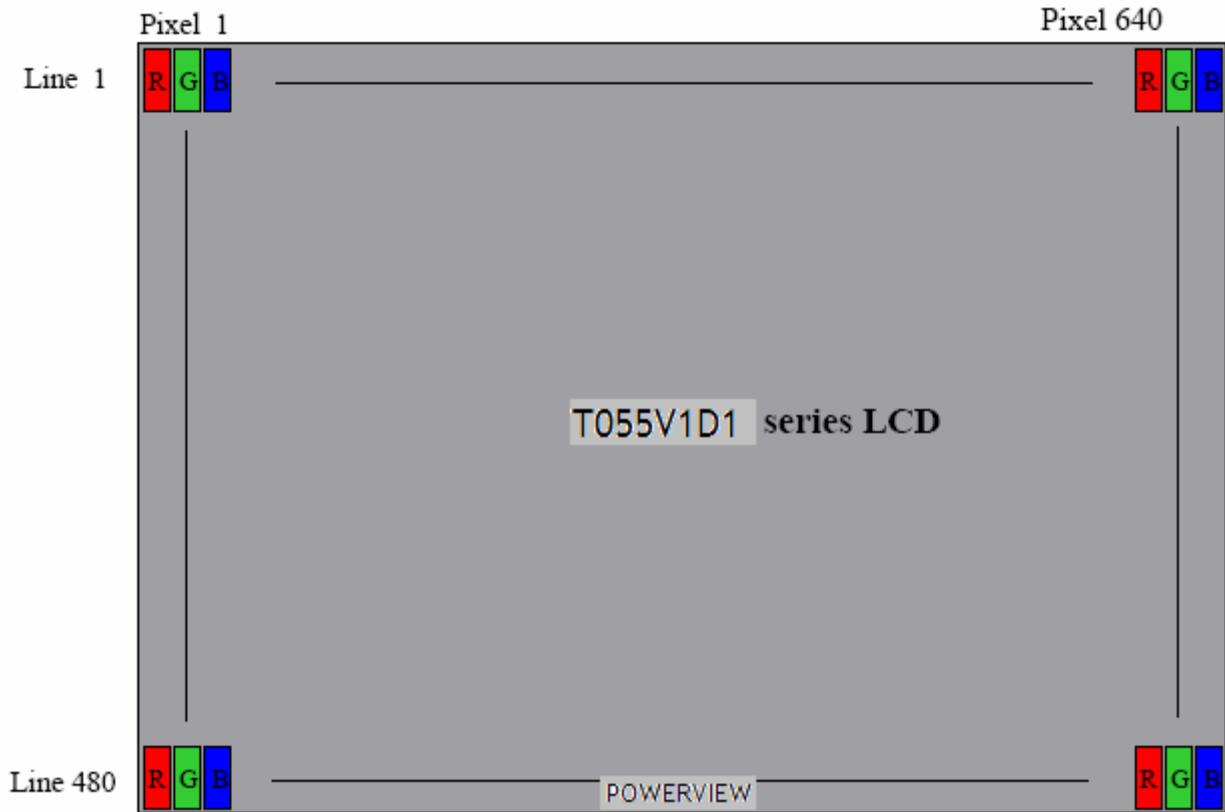

7.0 Display Outline Dimensions

7.1 Monitor Outline Dimensions

- Please refer to the next page

REV	EC NUMBER	DESCRIPTION	DATE
1	XXXXXX	XXXXXX	

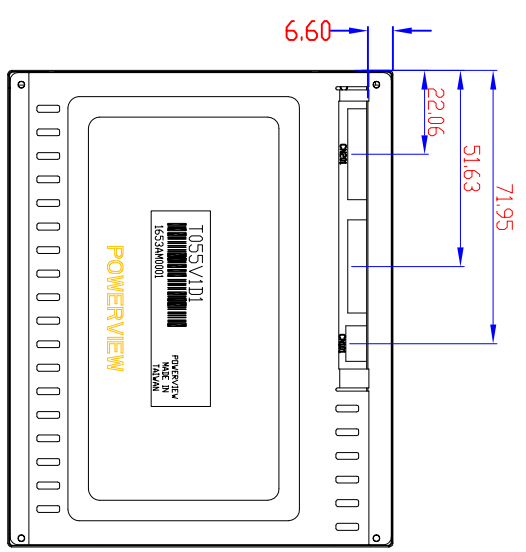
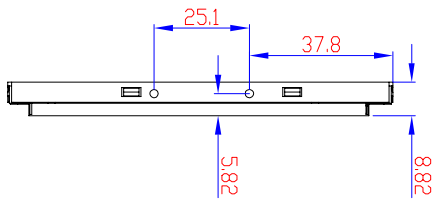
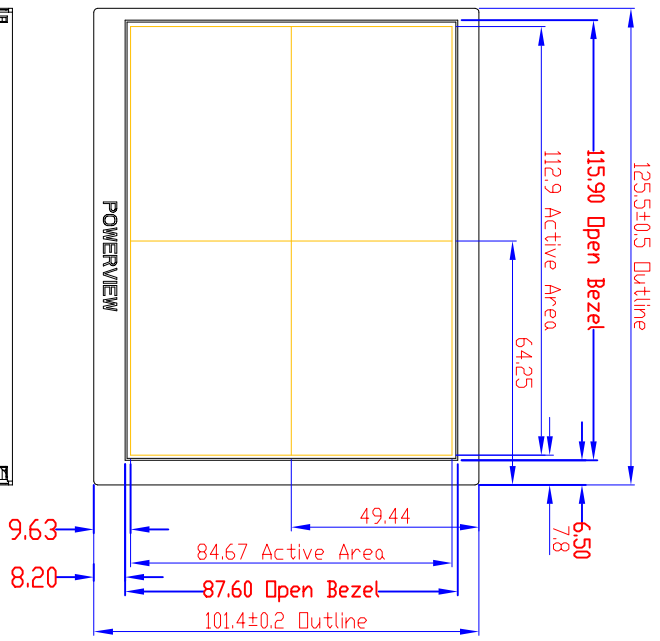
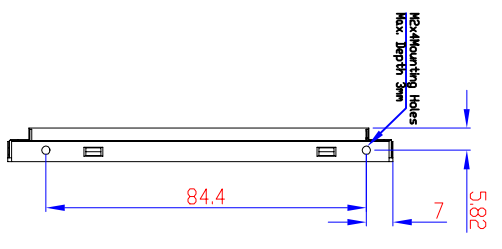
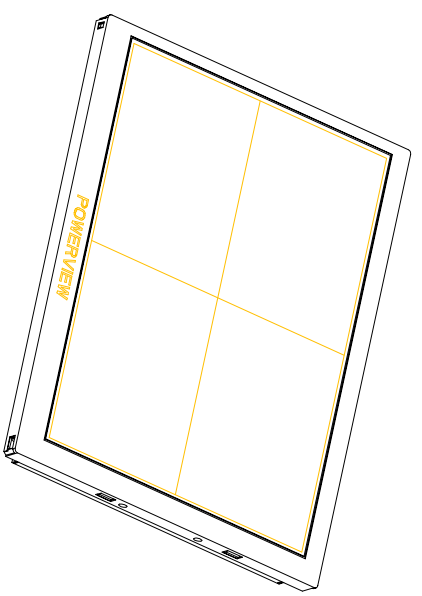

NO.	DESCRIPTION	QTY
1	GENERAL PURPOSE	1
2

POVERVIEW DISPLAY CORPORATION		All Rights Reserved	
MATERIAL	See notes	DATE	3rd ANGLE
FINISH	Finish	SCALE	1:1
CHECKED	Tim	DATE	2007/01/22
DESIGNED	Tim	REV	1-1

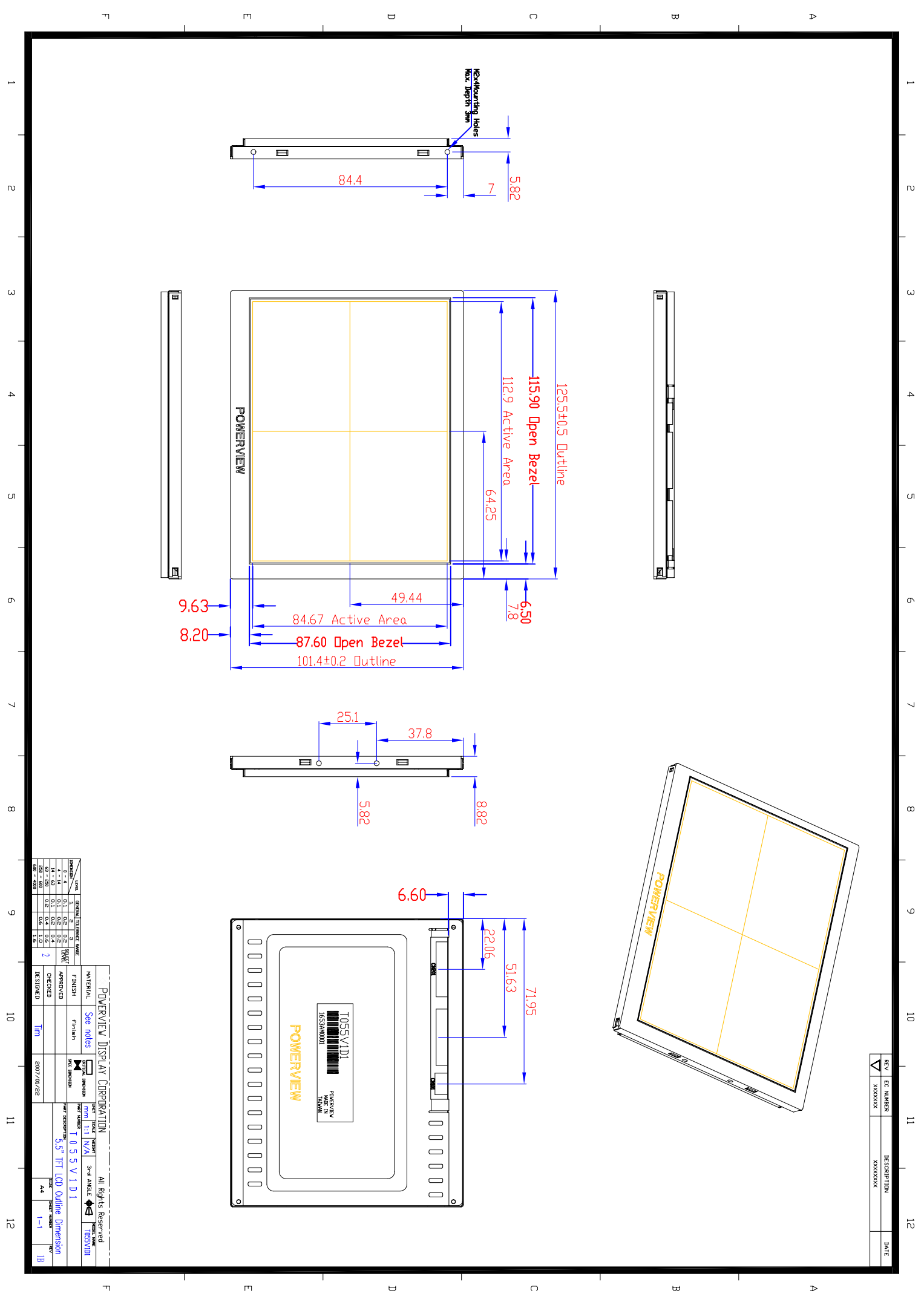



8.0 Labeling, Packaging & Others

* Labeling

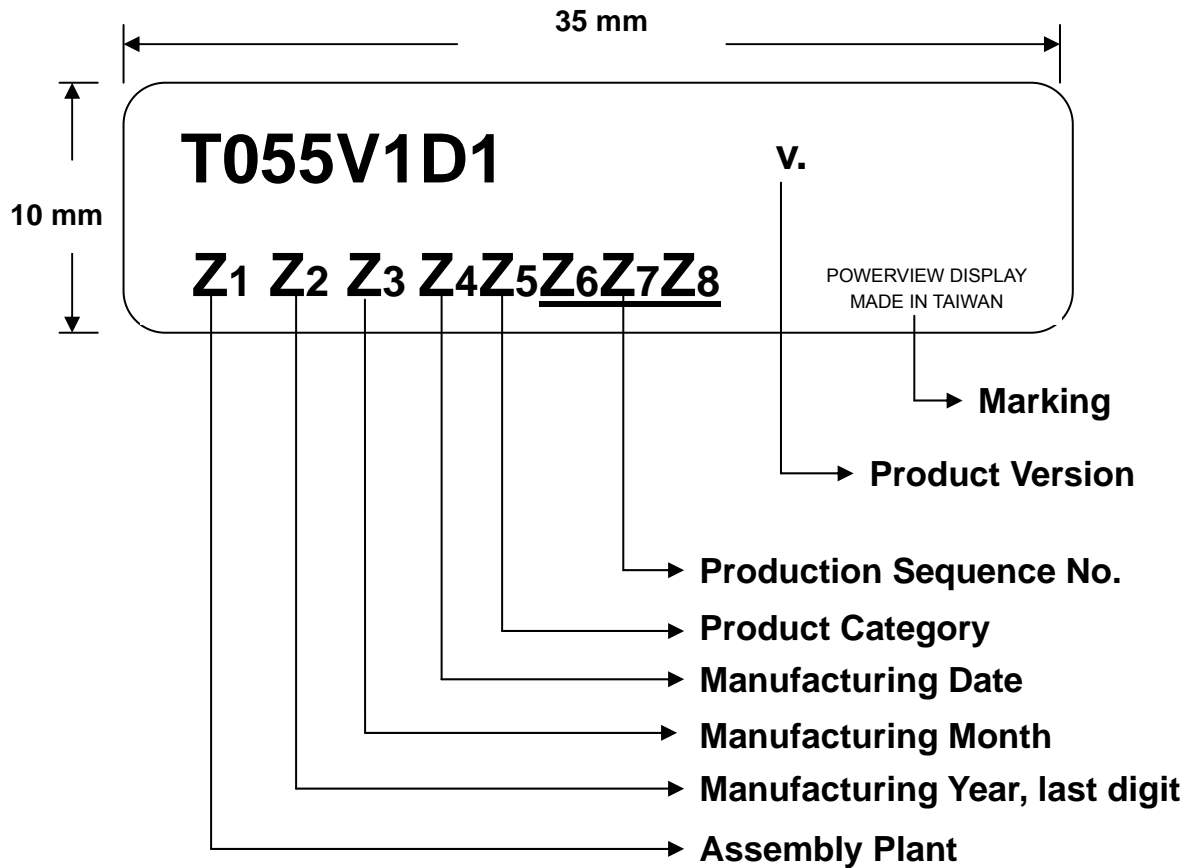

* Packaging

- TBD



Under Design



9.0 General Notice

9.1 Reliability Test Items (Note 2)

No.	Test Items	Conditions	Remark
1	High Temperature Storage	Ta= + 85°C 240 Hrs	
2	Low Temperature Storage	Ta= - 30°C 240 Hrs	
3	High Temperature Operation	Ta= + 70°C 240 Hrs	
4	Low Temperature Operation	Ta= - 30°C 240 Hrs	
5	High Temperature and High Humidity	Tp= 60°C, 90%RH 240 Hrs	operation
6	Heat Shock	-25~85°C/200 cycles 1Hr/cycle	Non-operation
7	Electrostatic discharge	±200V, 200pF(0Ω), once for each terminal	Non-operation
8	Vibration	Frequency range : 8~33.3 Hz Stoke : 1.3mm Sweep : 2.9G, 33.3~400Hz Cycle : 15 minutes 2 hours for each direction of X,Z 4 hours for Y direction	JIS C7021, A-10 Condition A
9	Mechanical Shock	100G, 6ms, ±X±Y±Z 3 times for each direction	JIS C7021, A-7 Condition C
10	Vibration (with carton)	Random vibration : 0.015G ² /Hz from 5~200Hz -6dB/octave from 200~500Hz	IEC 68-34
11	Drop (with carton)	Height : 60 cm 1 corner, 3 edges, 6 surfaces	JIS Z0202

Note1: Ta: Ambient temperature.

Note 2: In the standard conditions, there is not display function NG issue occurred. All the cosmetic specification is judged before the reliability stress.



9.2 Storage, Operation & Others

- (a) Do not leave the panel in high temperature, and high humidity for a long time.
It is highly recommended to store the module with temperature from 0 to 35°C and relative humidity of less than 70%.
- (b) Do not store the TFT-LCD module in direct sunlight.
- (c) The module shall be stored in a dark place. It is prohibited to apply sunlight or fluorescent light during the store.
- (d) Do not connect, disconnect the module in the "Power On" condition.
- (e) Power supply should always be turned on/off by the item 3.2 "Electrical Absolute Ratings"
- (f) The liquid-crystal is deteriorated by ultraviolet rays. Do not leave it in direct sunlight and strong ultraviolet rays for many hours.
- (g) Avoid condensation of water. It may result in improper operation or disconnection of electrode.
- (h) Do not exceed the absolute maximum rating value. (the supply voltage variation, input voltage variation, variation in part contents and environmental temperature, and so on) Otherwise the panel may be damaged.
- (i) If the panel displays the same pattern continuously for a long period of time, it can be the situation when the image "Sticks" to the screen.
- (j) This panel has its circuitry FPC on the bottom side and should be handled carefully in order not to be stressed.