



# TFT-LCD MONITOR

## Product Information

**Temporary**

**MODEL NO. : T055Q1D1**

**Date : 2008.01.12 Revision 0.1**

**Prepared by :**                     *Jason Cheng*                    

*Jason Cheng, Engineer, Product Development Div.*

**Approved by :**                     *Kelvin Hsieh*                    

*Kelvin Hsieh, Senior Engineer, Product Development Div.*

This TFT LCD Monitor is distributed by:



Display Solution AG  
Talhofstraße 32a  
D-82205 Gilching  
GERMANY  
Fon +49 (0)8105 / 73 403 - 0  
Fax +49 (0)8105 / 73 403 - 79  
E-Mail: info@display-solution.com  
Internet: www.display-solution.com

This product specification is subject to change without any notice.



## Records of Revision

| Date       | Rev. No. | Summary       | Page |
|------------|----------|---------------|------|
| 2008.01.12 | 0.1      | First Release | 1    |
|            |          |               |      |



| <b>Contents</b>                                 |          | <b>Page</b> |
|---|----------|-------------|
| <b>1.0 Handling Precautions</b>                 | -----    | <b>4</b>    |
| <b>2.0 General Description</b>                  | -----    | <b>5</b>    |
| 2.1 General Application                         | ----- 5  |             |
| 2.2 Main Features                               | ----- 5  |             |
| 2.3 General Information                         | ----- 5  |             |
| 2.3.1 Display Characteristics                   | ----- 5  |             |
| 2.3.2 Mechanical Dimensions                     | ----- 6  |             |
| <b>3.0 Absolute Maximum Ratings</b>             | -----    | <b>6</b>    |
| 3.1 Absolute Ratings of Environment Requirement | ----- 6  |             |
| 3.2 Electrical Absolute Ratings                 | ----- 6  |             |
| 3.2.1 TFT-LCD Module                            | ----- 6  |             |
| 3.2.2 Backlight Module(LED)                     | ----- 7  |             |
| <b>4.0 Optical Characteristics</b>              | -----    | <b>8</b>    |
| <b>5.0 Electrical Characteristics</b>           | -----    | <b>10</b>   |
| 5.1 AC Timing Characteristics                   | ----- 10 |             |
| 5.2 DC Characteristics                          | ----- 11 |             |
| 5.2.1 TFT-LCD Module                            | ----- 11 |             |
| 5.2.2 Backlight Unit & LED Driver               | ----- 11 |             |
| 5.3 Input Terminal Pin Assignment               | ----- 12 |             |
| 5.3.1 Signal Input Interface                    | ----- 12 |             |
| 5.3.2 LED Driver Unit                           | ----- 13 |             |
| 5.3.3 Scanning Direction                        | ----- 13 |             |
| 5.3.4 VGA Display Mode                          | ----- 14 |             |
| 5.3.4 Color Data Reference                      | ----- 14 |             |
| 5.4 Input Timing Chart                          | ----- 16 |             |
| <b>6.0 Pixel Format Image</b>                   | -----    | <b>17</b>   |
| <b>7.0 Display Outline Dimensions</b>           | -----    | <b>17</b>   |
| <b>8.0 Labeling, Packaging &amp; Others</b>     | -----    | <b>19</b>   |
| <b>9.0 General Notices</b>                      | -----    | <b>21</b>   |
| 9.1 Reliability Test Item                       | ----- 21 |             |
| 9.2 Storage, Operation & Others                 | ----- 22 |             |



## 1.0 Handling Precaution

- 1.) Handle with care. Pay attention not to press or scratch the surface of the monitor, especially the polarizer. Do not twist or bend the monitor. It may cause un-recoverable damage.
- 2.) Do not drop or bump the monitor since this monitor contains fragile glass components. Breakage of this monitor might cause leakage of the liquid crystal sealed inside the glasses. Do not touch the liquid crystal liquid in case of leakage. **Flush with massive water immediately in case of contact with your skin by liquid crystal fluid and call for doctor for immediate medical treatment.**
- 3.) Be sure to turn off power supply while plug or un-plug the power input connector.
- 4.) Clean up the polarizer only with soft solvent if necessary. The desirable cleaners are water, IPA(Isopropyl Alcohol) or Hexane. Do not use Ketone type materials (ex. Acetone), Ethyl alcohol, toluene, Ethyl acid or Methyl chloride. It will permanently damage the polarizer due to chemical reaction. 5.) Wipe off fluid drop immediately to prevent from possible discoloration or spots on the polarizer.
- 6.) Do not twist nor bend the monitor structure, even momentarily. Bending or twisting torque may likely damage the internal components of the monitor.
- 7.) Protect the monitor from static environment to prevent from damage to the CMOS gate array IC.



## 2.0 General Description

T055Q1D1 is a 5.5 inch (4:3 aspect ratio) color active matrix TFT LCD monitor with excellent display performance driven by a pure **DIGITAL** CMOS interface assembled in a compact and slim sunlight readable LED backlight unit. This LCD supports 320(H) x RGB x 240(V) stripe color pixel format and 262,144 colors (RGB 6 bits data) with vivid color image. Its outstanding performances with wide operation temperature range, **-30 ~ 70°C**, high brightness, **400 nits(typ.)**, wide viewing angle(140°/120°) and high contrast ratio 500:1, make this monitor very suitable for applications under severe environments or outdoor use.

### 2.1 General Applications

- Display terminal for applications of Car Navigation, Industrial, Medical, Gaming, Amusement, Advertisement and more

### 2.2 Main Features

- Ultra Slim boarder
- 5.5" 320xRGBx240 Resolution with 4:3 Display Aspect Ratio
- LED Backlight
- Excellent Brightness at low temperature
- Low Power Consumption
- High Brightness
- Wide Viewing Angle
- High Contrast Ratio
- Wide Temperature Range
- Pure Digital CMOS TTL Interface
- DE (Data Enable) Mode
- Thin and Light Weight
- LED Driver built-in
- RoHS Compliance

### 2.3 General Information

#### 2.3.1 Display Characteristics

| Item                   | Specification          | Unit   | Note      |
|------------------------|------------------------|--------|-----------|
| Display Area (HxV)     | 112.9 x 84.7           | mm     | -         |
| Driver Element         | a-Si TFT Active Matrix | -      | -         |
| Number of Pixels (HxV) | 320 xRGBx 240          | pixel  | Std. 4:3  |
| Pixel Arrangement      | R.G.B Vertical Stripe  | -      | -         |
| Pixel Pitch (HxV)      | (0.1176x3) x 0.3528    | mm     | Pixel     |
| Viewing Angle (H/V)    | 140/120                | degree | 6 o'clock |



|                  |                     |   |             |
|------------------|---------------------|---|-------------|
| Signal Interface | Digital RGB 18 bits |   | 262K colors |
| Display Mode     | Normally White      | - | -           |

### 2.3.2 Mechanical Dimensions

| Item      |            | Min. | Typ.  | Max. | Unit | Note    |
|-----------|------------|------|-------|------|------|---------|
| Dimension | Horizontal |      | 125.5 |      | mm   | ±0.5 mm |
|           | Vertical   |      | 101.4 |      |      | ±0.5 mm |
|           | Depth      | -    | 12.5  |      |      | ±0.5 mm |
| Weight    |            |      | 180   |      | g    | ±10 g   |

## 3.0 Absolute Maximum Ratings

### 3.1 Absolute Ratings of Environment Requirement

| Item   | Symbol | Min. | Max. | Unit | Note |
|--|--------|------|------|------|------|
| Storage Temperature                            | Tstg   | -30  | 85   | °C   |      |
| Operation Temperature<br>(Ambient Temperature) | Top    | -30  | 70   | °C   |      |

**Note (1)** Temperature and relative humidity range are shown in the figure below.

95% RH Max. ( $40^{\circ}\text{C} > T_a$ )

Maximum wet – bulb temperature at  $39^{\circ}\text{C}$  or less. ( $T_a > 40^{\circ}\text{C}$ ) No condensation.

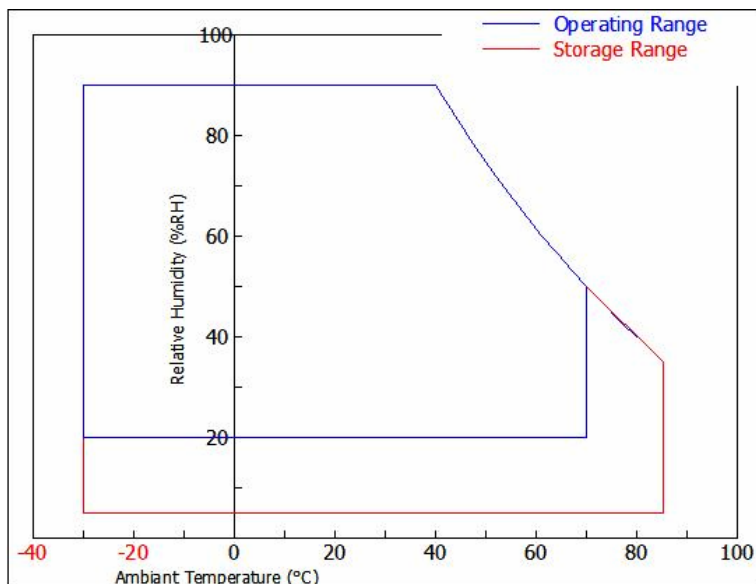

### 3.2 Electrical Absolute Ratings

#### 3.2.1 TFT-LCD Module

( $T_a = 25 \pm 2^{\circ}\text{C}$ ),  $V_{gg} = \text{GND} = 0\text{V}$ )

| Item                 | SYMBOL   | Min. | Max.           | UNIT | NOTE    |
|----------------------|----------|------|----------------|------|---------|
| Power Supply Voltage | $V_{DD}$ | -0.3 | 4.0            | V    | (1),(2) |
| Input Voltage        | $V_{i1}$ | -0.3 | $V_{DD} + 0.3$ | V    | (1),(2) |



### 3.2.2 Backlight Module(LED)

| Item             | SYMBOL          | MIN | MAX | UNIT | NOTE    |
|------------------|-----------------|-----|-----|------|---------|
| Input DC Voltage | V <sub>BL</sub> | -   | 15  | V    | (1),(2) |

**Note (1)** Within operating temperature

**Note (2)** Permanent damage to the device may occur if maximum values are exceeded. Functional operation should be restricted to the conditions described under normal operating conditions.



## 4.0 Optical Characteristics

The following items are measured under stable conditions in a dark room or equivalent state.

\* Measuring Equipment: BM-5A, PR-650

( $V_{DD}=3.3V$ ,  $f_V=60Hz$ ,  $f_H=15.75KHz$ ,  $T_a=25\pm 2^\circ C$ )

| Item                  | Symbol  | Condition                   | Min.                         | Typ.   | Max. | Unit              | Note          |
|-----------------------|---------|-----------------------------|------------------------------|--------|------|-------------------|---------------|
| Contrast Ratio        | CR      | At optimized Viewing Angle  |                              | 500    | -    | -                 | (1)(2)<br>(4) |
| Response Time at 25°C | Rising  | $T_R$                       | -                            | 15     |      | ms                | (3)           |
|                       | Falling | $T_F$                       | -                            | 10     |      |                   |               |
| Luminance             | $Y_L$   | $V_{Dim}=V_{max}$ ,<br>25°C |                              | 400    | -    | cd/m <sup>2</sup> | (1)(2)<br>(6) |
| Viewing Angle         | Hor.    | $\theta_L$                  | CR $\geq$ 10 at center point | 70     | -    | Degree            | (2)(5)        |
|                       |         | $\theta_R$                  |                              | 70     | -    |                   |               |
|                       | Ver.    | $\theta_H$                  |                              | 50     | -    |                   |               |
|                       |         | $\theta_L$                  |                              | 70     | -    |                   |               |
| Brightness Endurance  | +25°C   | -                           | Continuous Operation         | 50,000 | -    | hour              | (7)           |

**Note (1)** : Ambient temperature =25°C , and lamp current  $V_{DIM} = V_{max}$  by using mode 1. To be measured in the dark room.

**Note (2)** : To be measured on the center area of panel with a viewing cone of 1° by Topcon Luminance Meter BM-5, after 10 minutes operation.

**Note (3)** : Definition of response time:

The output signals of photo detector are measured when the input signals are changed from "black" to "white"(falling time) and from "white" to "black"(rising time), respectively.

The response time is defined as the time interval between the 10% and 90% of amplitudes. Refer to figure as below.

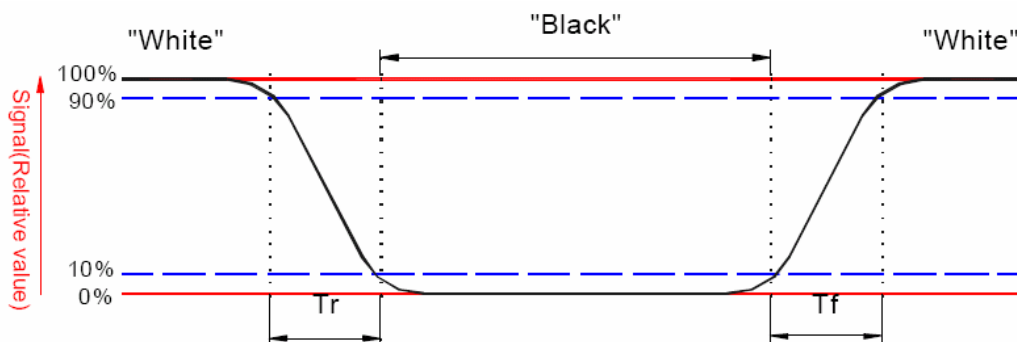



**Note (4)** : Definition of contrast ratio:

Contrast ratio is calculated with the following formula.

$$\text{Contrast ratio (CR)} = \frac{\text{Photo detector output when LCD is at "White" state}}{\text{Photo detector output when LCD is at "Black" state}}$$

**Note (5)** : Definition of viewing angle, Refer to figure as below.

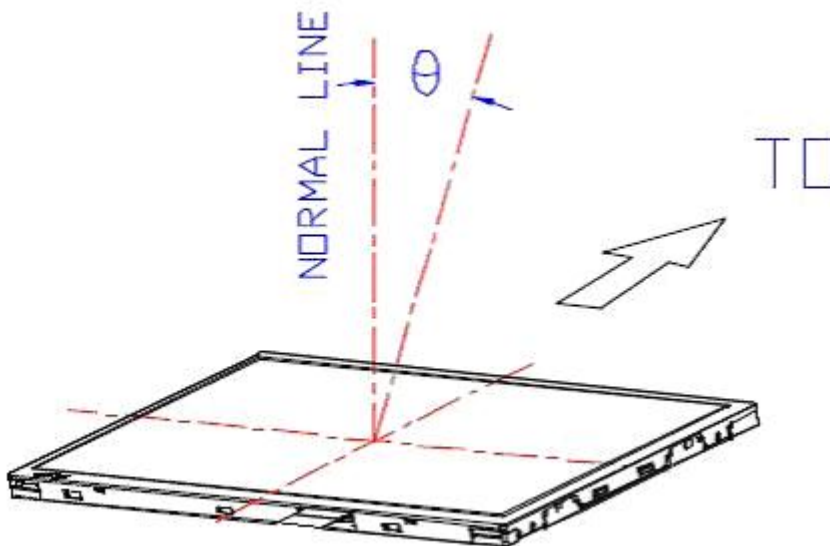

**Note (6)** : Measured at the center area of the panel when all the input terminals of LCD panel are electrically opened.

**Note (7)** : Continuous operation time which doesn't deteriorate the brightness under 50% of the brightness at the beginning measured at room temperature at full brightness.



## 5.0 Electrical Characteristics

### 5.1 AC Timing Characteristics

#### 5.1.1 VGA mode

| Item                 | Symbol                   | Min. | Typ.  | Max.           | Unit  | Note |
|----------------------|--------------------------|------|-------|----------------|-------|------|
| Clock Frequency      | $F_{ck}$                 |      | 25.18 | 30             | MHz   |      |
|                      | $T_{ck}$                 | 33.3 | 39.7  |                | ns    |      |
| Clock Duty Ratio     | $T_{ch}/(T_{ch}+T_{cl})$ | 40   | 50    | 60             | %     |      |
| Horizontal Display   | $T_h$                    |      | 800   |                | clk   |      |
|                      | $T_{hd}$                 | 640  | 640   | 640            | clk   |      |
|                      | $T_{hw}$                 |      | 10    |                | clk   |      |
|                      | $T_{he}$                 | -    | TBD   |                | clk   |      |
| Vertical Display     | Frame Rate               |      | 60    |                | Hz    |      |
|                      | $T_v$                    |      | 525   |                | $T_h$ |      |
|                      | $T_{vd}$                 | 480  | 480   | 480            | $T_h$ |      |
|                      | $T_{vw}$                 |      | 2     |                | $T_h$ |      |
|                      | $T_{ve}$                 |      | TBD   |                | $T_h$ |      |
| Data Setup Time      | $T_{ds}$                 | 12   | -     | -              | ns    |      |
| Data Hold Time       | $T_{dh}$                 | 12   | -     | -              | ns    |      |
| DE Setup Time        | $T_{es}$                 | 12   | -     | -              | ns    |      |
| Hs to CLK difference | $T_{hc}$                 | 12   |       | $T_{ck} - 12$  | ns    |      |
| Vs to Hs difference  | $T_{vpd}$                | 12   |       | $T_h - T_{hw}$ | ns    |      |

#### 5.1.2 QVGA mode

| Item               | Symbol                   | Min.  | Typ.  | Max. | Unit  | Note |
|--------------------|--------------------------|-------|-------|------|-------|------|
| Clock Frequency    | $F_{ck}$                 |       | 6.4   | 7.0  | MHz   |      |
|                    | $T_{ck}$                 | 142.9 | 156.3 |      | ns    |      |
| Clock Duty Ratio   | $T_{ch}/(T_{ch}+T_{cl})$ | 40    | 50    | 60   | %     |      |
| Horizontal Display | $T_h$                    |       | 404   |      | clk   |      |
|                    | $T_{hd}$                 | 320   | 320   | 320  | clk   |      |
|                    | $T_{hw}$                 |       | 10    |      | clk   |      |
|                    | $T_{he}$                 | -     | TBD   |      | clk   |      |
| Vertical Display   | Frame Rate               |       | 60    |      | Hz    |      |
|                    | $T_v$                    |       | 262   |      | $T_h$ |      |
|                    | $T_{vd}$                 | 240   | 240   | 240  | $T_h$ |      |
|                    | $T_{vw}$                 |       | 2     |      | $T_h$ |      |
|                    | $T_{ve}$                 |       | TBD   |      | $T_h$ |      |
| Data Setup Time    | $T_{ds}$                 | 12    | -     | -    | ns    |      |



|                      |           |    |   |                |    |  |
|----------------------|-----------|----|---|----------------|----|--|
| Data Hold Time       | $T_{dh}$  | 12 | - | -              | ns |  |
| DE Setup Time        | $T_{es}$  | 12 | - | -              | ns |  |
| Hs to CLK difference | $T_{hc}$  | 12 |   | $T_{ck} - 12$  | ns |  |
| Vs to Hs difference  | $T_{vpd}$ | 12 |   | $T_h - T_{hw}$ | ns |  |

## 5.2 DC Characteristics

### 5.2.1 TFT-LCD Module

| Item                            | Symbol   | Min.         | Typ.  | Max.         | Unit              | Note          |
|---------------------------------|----------|--------------|-------|--------------|-------------------|---------------|
| Power Supply                    | $V_{DD}$ | 3.0          | 3.3   | 3.6          | V                 | (1)           |
| Permissive Input Ripple Voltage | $V_{RF}$ | -            | -     | 100          | mV <sub>P-P</sub> |               |
| Power Supply Current            | $I_{DD}$ | -            | (220) | -            | mA                | $V_{DD}=3.3V$ |
| Logic Input Voltage             | $V_{IL}$ | 0            | -     | $0.3 V_{DD}$ | V                 | (2)           |
|                                 | $V_{IH}$ | $0.7 V_{DD}$ | -     | $V_{DD}$     | V                 | (2)           |

**Note (1)** VDD Power-On Condition :

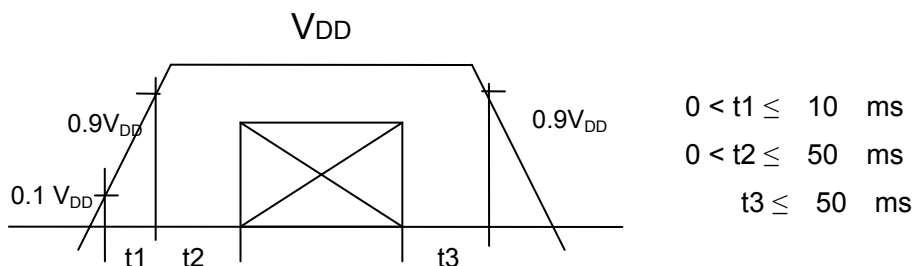

**Note (2)** CLK, Hsync, Vsync, DE, R0~R5, G0~G5, B0~B5

### 5.2.2 Backlight Unit & LED Driver

| Item         | Symbol   | Min. | Typ.   | Max. | Unit | Note   |
|--------------|----------|------|--------|------|------|--------|
| Power Supply | $V_{BL}$ | 10.8 | 12     | 13.2 | V    |        |
|              | $I_{BL}$ |      | (0.16) |      | Amp  | Note 2 |

Note (1)  $V_{BL}$  Power-On Condition for LED driver :

**Please make sure the control signals for LED driver must arrive after the power supply of LED driver,  $V_{BL}$ .**

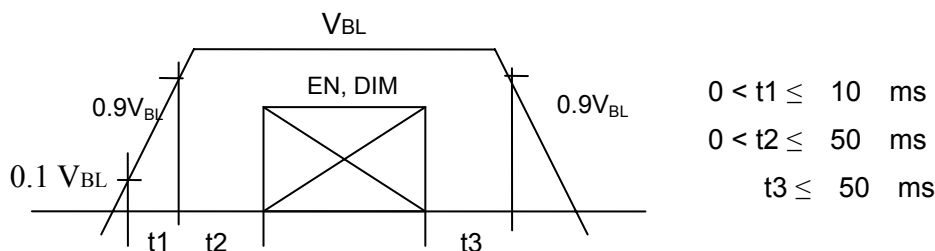

Note 2 :  $V_{BL} = 12V$ , set  $V_{DIM} = 0V$  to get the maximum brightness.



### 5.3 Input Terminal Pin Assignment

#### 5.3.1 Signal Input Interface

33pin 0.5mmpitch FFC/FPC connector, Type : Kyocera Elco/08-6210-033-340-800

| Pin No | Symbol          | Description   | Remark |
|--------|-----------------|---|--------|
| 1      | GND             | Ground  | -      |
| 2      | CLK             | Data Clock  | -      |
| 3      | Hsync           | Horizontal Sync.  | -      |
| 4      | Vsync           | Vertical Sync.  | -      |
| 5      | GND             | Ground  | -      |
| 6      | R0              | Red Data (LSB)  | -      |
| 7      | R1              | Red Data  | -      |
| 8      | R2              | Red Data  | -      |
| 9      | R3              | Red Data  | -      |
| 10     | R4              | Red Data  | -      |
| 11     | R5              | Red Data (MSB)  | -      |
| 12     | GND             | Ground  | -      |
| 13     | G0              | Green Data (LSB)  | -      |
| 14     | G1              | Green Data  | -      |
| 15     | G2              | Green Data  | -      |
| 16     | G3              | Green Data  | -      |
| 17     | G4              | Green Data  | -      |
| 18     | G5              | Green Data (MSB)  | -      |
| 19     | GND             | Ground  | -      |
| 20     | B0              | Blue Data (LSB)   | -      |
| 21     | B1              | Blue Data   | -      |
| 22     | B2              | Blue Data   | -      |
| 23     | B3              | Blue Data   | -      |
| 24     | B4              | Blue Data   | -      |
| 25     | B5              | Blue Data (MSB)   | -      |
| 26     | GND             | Ground  | -      |
| 27     | ENA             | Data Enable   | -      |
| 28     | V <sub>DD</sub> | Power Supply (+3.3V)  | -      |
| 29     | V <sub>DD</sub> | Power Supply (+3.3V)  | -      |
| 30     | DPSH            | Select of the horizontal scan direction<br>(L or Open: Normal, H :Reverse Mode) | -      |
| 31     | DPSV            | Select of the vertical scan direction<br>(L or Open: Normal, H :Reverse Mode)   | -      |
| 32     | PNS             | Select of the pixel number<br>(L or Open: VGA mode, H:QVGA mode)                | -      |
| 33     | GND             | Ground  | -      |



### 5.3.2 LED Driver Unit

Connector : Molex 53261-0890 or equivalent

#### Mode 1

Matching Connector : Molex 51021-0800 or equivalent

| Pin No. | Symbol           | Description                 | Remark |
|---------|------------------|-----------------------------|--------|
| 1       | V <sub>BL</sub>  | Power Supply for LED Driver |        |
| 2       | V <sub>BL</sub>  | Power Supply for LED Driver |        |
| 3       | GND              | Ground Pin for LED Driver   |        |
| 4       | GND              | Ground Pin for LED Driver   |        |
| 5       | V <sub>EN</sub>  | LED Enable Control Input    | Note 1 |
| 6       | V <sub>DIM</sub> | Dimming Control Input       | Note 2 |
| 7       | GND              | Ground Pin for LED Driver   |        |
| 8       | V <sub>ST</sub>  | The Warning Output          | Note 3 |

Note 1 : Disable V<sub>EN</sub> < 0.6 V, Enable V<sub>EN</sub> > 1.6 V

Note 2 : Max Brightness V<sub>DIM</sub> : DC 0V, Min Brightness V<sub>DIM</sub> : DC 5V ( ≈ 0 Nit )

Note 3 : V<sub>ST</sub> will output 3.3V DC voltage when the backlight cable is not connected or the backlight unit is abnormal.

### 5.3.3 Scanning Direction

**Viewing Direction : Front View**

**Arrow Head Direction : Scanning Sequence**

DPSH = LOW DPSV = LOW

DPSH = HIGH DPSV = LOW

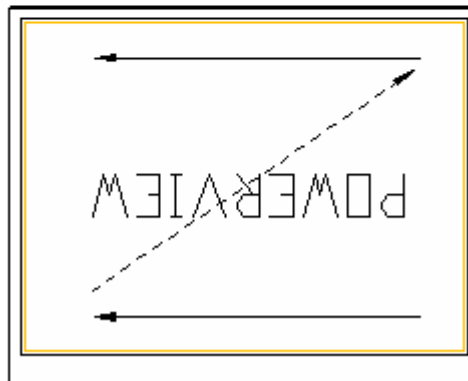
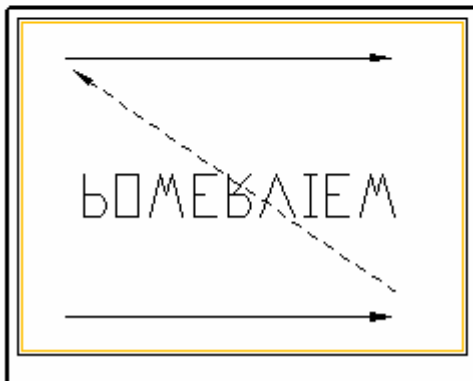
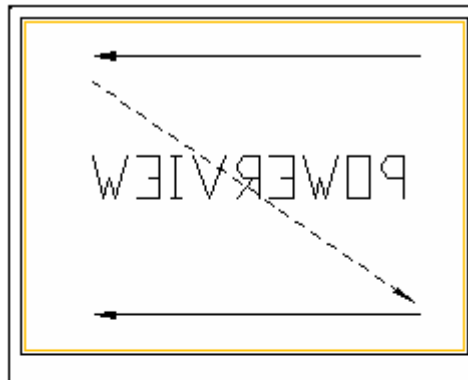
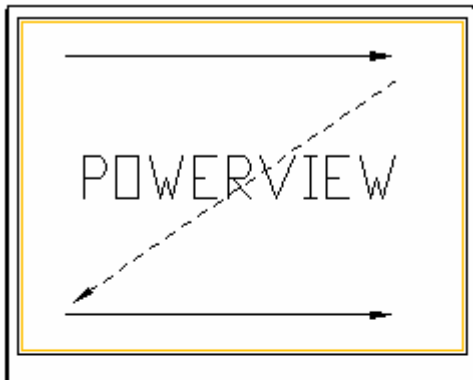

DPSH = LOW DPSV = HIGH

DPSH = HIGH DPSV = HIGH



### 5.3.4 VGA Display Mode

T055Q1D1 can also adopt VGA timing signal and display the data on its QVGA screen. It will, however, display the upper-left quarter corner of the whole VGA data format only, as illustrated under the below 4 diagrams.

**Viewing Direction : Front View      Arrow Head Direction : Scanning Sequence**

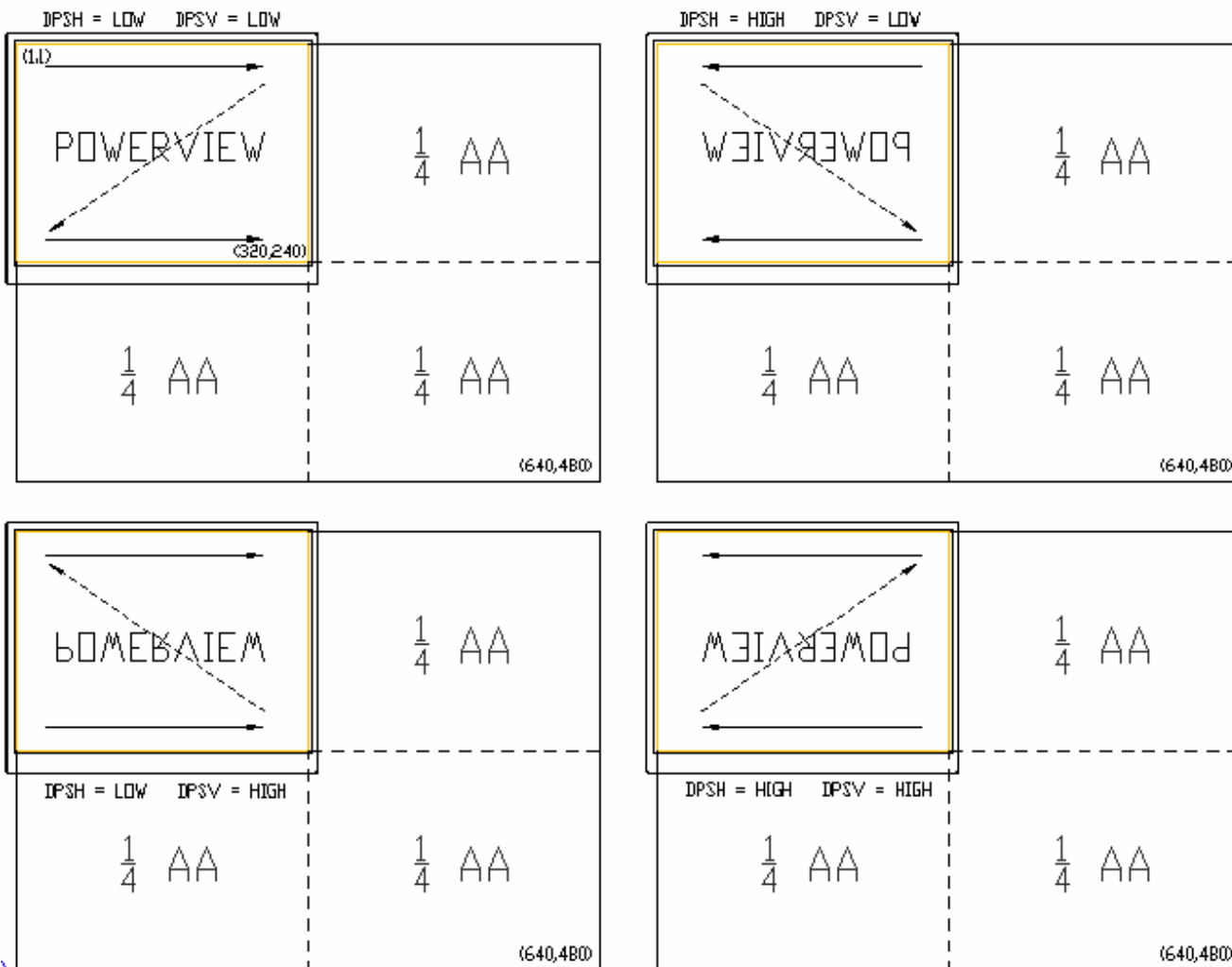

### 5.3.5 Color Data Reference

The below table is about nput signal, Basic display colors and gray scale of each color.

0 : Low Level Voltage      1 : High Level Voltage

Each basic color can be displayed in 64 gray scales from 6 bit data signals. With the combination of total 18 bit data signals, the 262,144 color display can be achieved on the screen.

- Please refer to the next page



|                     | Colors & Gray Scale | Data Signal |    |    |    |    |    |    |    |    |    |    |    |    |    |    |    |    |    |    |
|---------------------|---------------------|-------------|----|----|----|----|----|----|----|----|----|----|----|----|----|----|----|----|----|----|
|                     |                     | Gray Scale  | R0 | R1 | R2 | R3 | R4 | R5 | G0 | G1 | G2 | G3 | G4 | G5 | B0 | B1 | B2 | B3 | B4 | B5 |
| Basic Color         | Black               | -           | 0  | 0  | 0  | 0  | 0  | 0  | 0  | 0  | 0  | 0  | 0  | 0  | 0  | 0  | 0  | 0  | 0  | 0  |
|                     | Blue                | -           | 0  | 0  | 0  | 0  | 0  | 0  | 0  | 0  | 0  | 0  | 0  | 0  | 1  | 1  | 1  | 1  | 1  | 1  |
|                     | Green               | -           | 0  | 0  | 0  | 0  | 0  | 0  | 1  | 1  | 1  | 1  | 1  | 1  | 0  | 0  | 0  | 0  | 0  | 0  |
|                     | Cyan                | -           | 0  | 0  | 0  | 0  | 0  | 0  | 1  | 1  | 1  | 1  | 1  | 1  | 1  | 1  | 1  | 1  | 1  | 1  |
|                     | Red                 | -           | 1  | 1  | 1  | 1  | 1  | 1  | 0  | 0  | 0  | 0  | 0  | 0  | 0  | 0  | 0  | 0  | 0  | 0  |
|                     | Magenta             | -           | 1  | 1  | 1  | 1  | 1  | 1  | 0  | 0  | 0  | 0  | 0  | 0  | 1  | 1  | 1  | 1  | 1  | 1  |
|                     | Yellow              | -           | 1  | 1  | 1  | 1  | 1  | 1  | 1  | 1  | 1  | 1  | 1  | 1  | 0  | 0  | 0  | 0  | 0  | 0  |
|                     | White               | -           | 1  | 1  | 1  | 1  | 1  | 1  | 1  | 1  | 1  | 1  | 1  | 1  | 1  | 1  | 1  | 1  | 1  | 1  |
| Gray Scale of Red   | Black               | GS0         | 0  | 0  | 0  | 0  | 0  | 0  | 0  | 0  | 0  | 0  | 0  | 0  | 0  | 0  | 0  | 0  | 0  | 0  |
|                     | ↑                   | GS1         | 1  | 0  | 0  | 0  | 0  | 0  | 0  | 0  | 0  | 0  | 0  | 0  | 0  | 0  | 0  | 0  | 0  | 0  |
|                     | Darker              | GS2         | 0  | 1  | 0  | 0  | 0  | 0  | 0  | 0  | 0  | 0  | 0  | 0  | 0  | 0  | 0  | 0  | 0  | 0  |
|                     | ↑                   | ↓           |    |    |    |    |    | ↓  |    |    |    |    | ↓  |    |    |    |    |    |    |    |
|                     | ↓                   | ↓           |    |    |    |    |    | ↓  |    |    |    |    | ↓  |    |    |    |    |    |    |    |
|                     | Brighter            | GS61        | 1  | 0  | 1  | 1  | 1  | 1  | 0  | 0  | 0  | 0  | 0  | 0  | 0  | 0  | 0  | 0  | 0  | 0  |
|                     | ↓                   | GS62        | 0  | 1  | 1  | 1  | 1  | 1  | 0  | 0  | 0  | 0  | 0  | 0  | 0  | 0  | 0  | 0  | 0  | 0  |
| Red                 | GS63                | 1           | 1  | 1  | 1  | 1  | 1  | 0  | 0  | 0  | 0  | 0  | 0  | 0  | 0  | 0  | 0  | 0  | 0  |    |
| Gray Scale of Green | Black               | GS0         | 0  | 0  | 0  | 0  | 0  | 0  | 0  | 0  | 0  | 0  | 0  | 0  | 0  | 0  | 0  | 0  | 0  | 0  |
|                     | ↑                   | GS1         | 0  | 0  | 0  | 0  | 0  | 0  | 1  | 0  | 0  | 0  | 0  | 0  | 0  | 0  | 0  | 0  | 0  | 0  |
|                     | Darker              | GS2         | 0  | 0  | 0  | 0  | 0  | 0  | 0  | 1  | 0  | 0  | 0  | 0  | 0  | 0  | 0  | 0  | 0  | 0  |
|                     | ↑                   | ↓           |    |    |    |    |    | ↓  |    |    |    |    |    |    |    |    |    |    |    |    |
|                     | ↓                   | ↓           |    |    |    |    |    | ↓  |    |    |    |    |    |    |    |    |    |    |    |    |
|                     | Brighter            | GS61        | 0  | 0  | 0  | 0  | 0  | 0  | 1  | 0  | 1  | 1  | 1  | 1  | 0  | 0  | 0  | 0  | 0  | 0  |
|                     | ↓                   | GS62        | 0  | 0  | 0  | 0  | 0  | 0  | 0  | 1  | 1  | 1  | 1  | 1  | 0  | 0  | 0  | 0  | 0  | 0  |
|                     | Green               | GS63        | 0  | 0  | 0  | 0  | 0  | 0  | 1  | 1  | 1  | 1  | 1  | 1  | 0  | 0  | 0  | 0  | 0  | 0  |
| Gray Scale of Blue  | Black               | GS0         | 0  | 0  | 0  | 0  | 0  | 0  | 0  | 0  | 0  | 0  | 0  | 0  | 0  | 0  | 0  | 0  | 0  | 0  |
|                     | ↑                   | GS1         | 0  | 0  | 0  | 0  | 0  | 0  | 0  | 0  | 0  | 0  | 0  | 0  | 1  | 0  | 0  | 0  | 0  | 0  |
|                     | Darker              | GS2         | 0  | 0  | 0  | 0  | 0  | 0  | 0  | 0  | 0  | 0  | 0  | 0  | 0  | 1  | 0  | 0  | 0  | 0  |
|                     | ↑                   | ↓           |    |    |    |    |    |    |    |    |    |    |    |    |    |    |    |    |    |    |
|                     | ↓                   | ↓           |    |    |    |    |    |    |    |    |    |    |    |    |    |    |    |    |    |    |
|                     | Brighter            | GS61        | 0  | 0  | 0  | 0  | 0  | 0  | 0  | 0  | 0  | 0  | 0  | 0  | 1  | 0  | 1  | 1  | 1  | 1  |
|                     | ↓                   | GS62        | 0  | 0  | 0  | 0  | 0  | 0  | 0  | 0  | 0  | 0  | 0  | 0  | 0  | 1  | 1  | 1  | 1  | 1  |
|                     | Blue                | GS63        | 0  | 0  | 0  | 0  | 0  | 0  | 0  | 0  | 0  | 0  | 0  | 0  | 1  | 1  | 1  | 1  | 1  | 1  |

This specification data sheet is an intellectual property of PowerView Display Corporation. Any copy, reproduction or modification without written permission of PowerView Display Corporation is not allowed.

# 5.4 Input Timing Chart

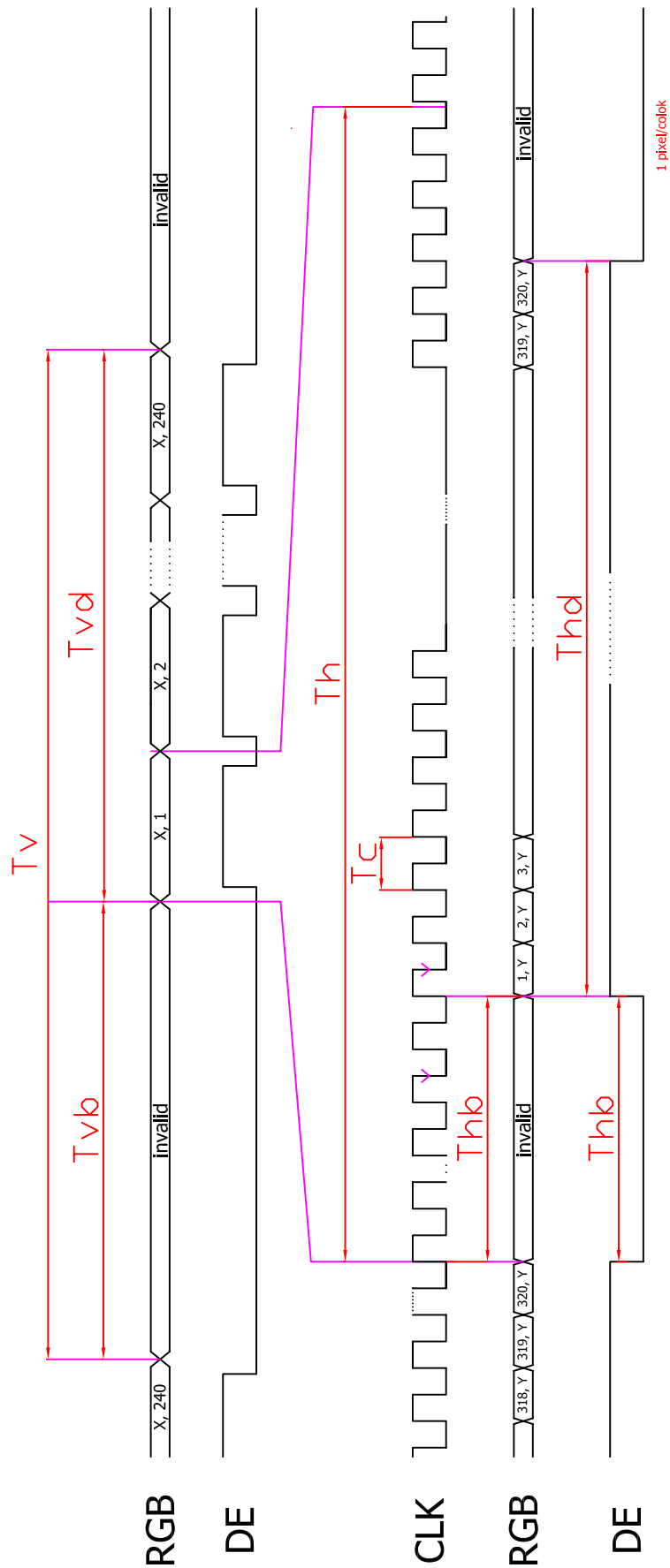



## 6.0 Pixel Format Image

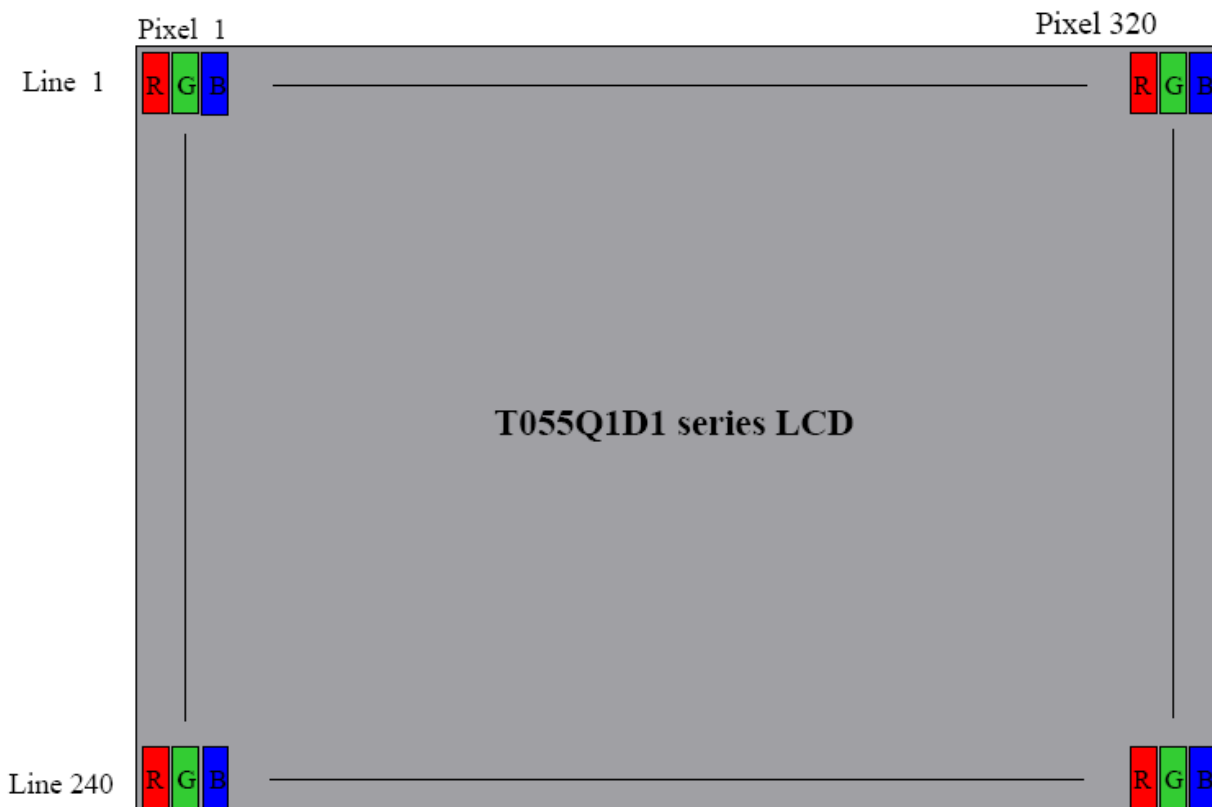

## 7.0 Display Outline Dimensions

### 7.1 Monitor Outline Dimensions

- Please refer to the next page





## 8.0 Labeling, Packaging & Others

### \* Labeling

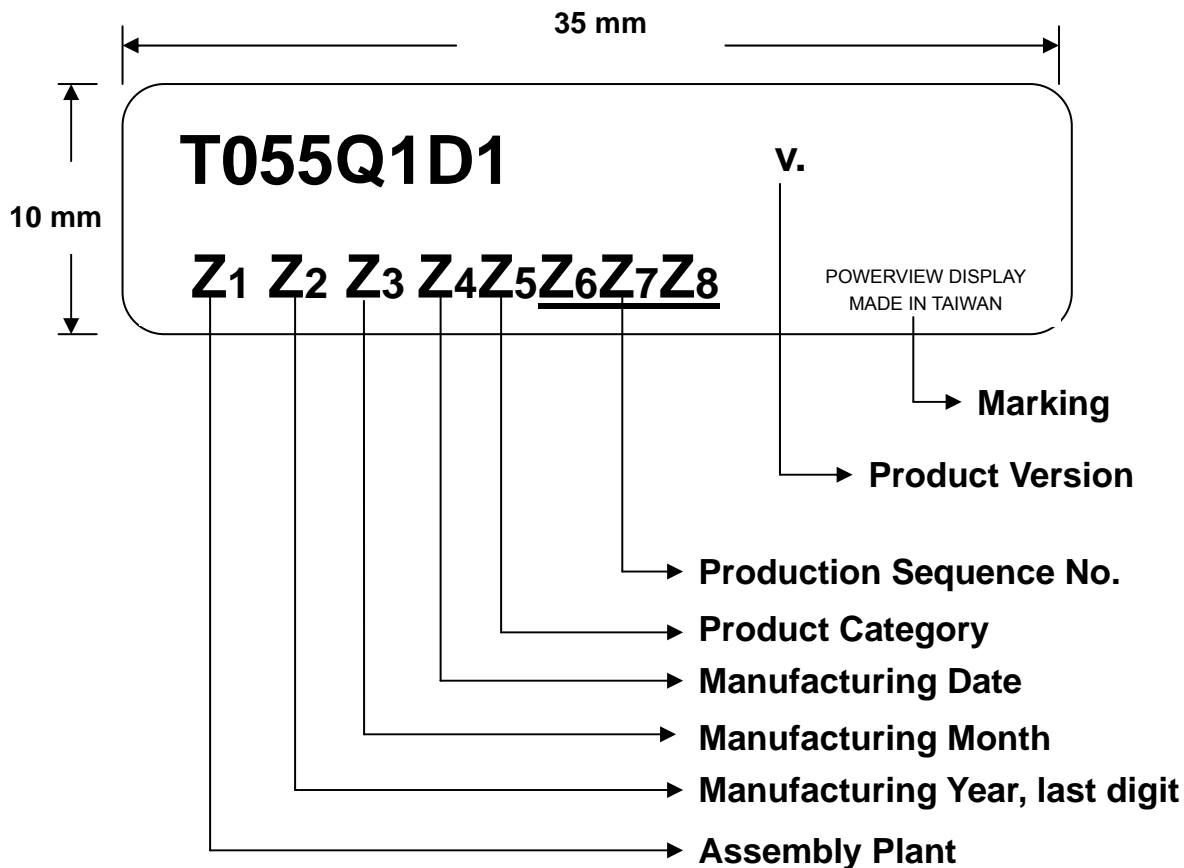

### \* Packaging

- TBD





## 9.0 General Notice

### 9.1 Reliability Test Items (Note 2)

| No. | Test Items                         | Conditions  | Remark                            |
|-----|------------------------------------|---|-----------------------------------|
| 1   | High Temperature Storage           | Ta= + 85°C                      240 Hrs   |                                   |
| 2   | Low Temperature Storage            | Ta= - 25°C                      240 Hrs   |                                   |
| 3   | High Temperature Operation         | Ta= + 70°C                      240 Hrs   |                                   |
| 4   | Low Temperature Operation          | Ta= - 20°C                      240 Hrs   |                                   |
| 5   | High Temperature and High Humidity | Tp= 60°C, 90%RH              240 Hrs  | operation                         |
| 6   | Heat Shock                         | -25~85°C/200 cycles 1Hr/cycle   | Non-operation                     |
| 7   | Electrostatic discharge            | ±200V, 200pF(0Ω), once for each terminal  | Non-operation                     |
| 8   | Vibration                          | Frequency range : 8~33.3 Hz<br>Stoke                      : 1.3mm<br>Sweep                      : 2.9G, 33.3~400Hz<br>Cycle                      : 15 minutes<br>2 hours for each direction of X,Z<br>4 hours for Y direction | JIS C7021,<br>A-10<br>Condition A |
| 9   | Mechanical Shock                   | 100G, 6ms, ±X±Y±Z<br>3 times for each direction   | JIS C7021,<br>A-7<br>Condition C  |
| 10  | Vibration (with carton)            | Random vibration :<br>0.015G <sup>2</sup> /Hz from 5~200Hz<br>-6dB/octave from 200~500Hz  | IEC 68-34                         |
| 11  | Drop (with carton)                 | Height : 60 cm<br>1 corner, 3 edges, 6 surfaces   | JIS Z0202                         |

Note1: Ta: Ambient temperature.

Note 2: In the standard conditions, there is not display function NG issue occurred. All the cosmetic specification is judged before the reliability stress.



## 9.2 Storage, Operation & Others

- (a) Do not leave the panel in high temperature, and high humidity for a long time.  
It is highly recommended to store the module with temperature from 0 to 35°C and relative humidity of less than 70%.
- (b) Do not store the TFT-LCD module in direct sunlight.
- (c) The module shall be stored in a dark place. It is prohibited to apply sunlight or fluorescent light during the store.
- (d) Do not connect, disconnect the module in the "Power On" condition.
- (e) Power supply should always be turned on/off by the item 3.2 "Electrical Absolute Ratings"
- (f) The liquid-crystal is deteriorated by ultraviolet rays. Do not leave it in direct sunlight and strong ultraviolet rays for many hours.
- (g) Avoid condensation of water. It may result in improper operation or disconnection of electrode.
- (h) Do not exceed the absolute maximum rating value. (the supply voltage variation, input voltage variation, variation in part contents and environmental temperature, and so on) Otherwise the panel may be damaged.
- (i) If the panel displays the same pattern continuously for a long period of time, it can be the situation when the image "Sticks" to the screen.
- (j) This panel has its circuitry FPC on the bottom side and should be handled carefully in order not to be stressed.