



TFT-LCD MONITOR

Product Information

(Preliminary)

MODEL NO. : T043W1D1

Date : 2008.11.18 **Revision : 0.1**

Prepared by : *Nicolas Hsieh*

Nicolas Shieh, Engineer, Product Development Div.

Approved by : **Jackey Chien**

Jackey Chien, Director, Product Development Div.

Note :

This TFT LCD Monitor is distributed by:



Display Solution AG
Talhofstraße 32a
D-82205 Gilching
GERMANY
Fon +49 (0)8105 / 73 403 - 0
Fax +49 (0)8105 / 73 403 - 79
E-Mail: info@display-solution.com
Internet: www.display-solution.com

This product specification is subject to change without any notice.



Records of Revision

Date	Rev. No.	Summary	Page
2008/11/18	01	First issue	1



Contents	Page
1.0 Handling Precautions	4
2.0 General Description	5
2.1 General Application	5
2.2 Main Features	5
2.3 General Information	5
2.3.1 Display Characteristics	5
2.3.2 Mechanical Dimensions	5
3.0 Absolute Maximum Ratings	6
3.1 Absolute Ratings of Environment Requirement	6
3.2 Electrical Absolute Ratings	6
3.2.1 TFT-LCD Module	6
4.0 Optical Characteristics	7
5.0 Electrical Characteristics	9
5.1 AC Timing Characteristics	9
5.2 DC Characteristics	9
5.2.1 TFT-LCD Module	9
5.2.2 DC-DC for LED Backlight	10
5.3 Input Terminal Pin Assignment	10
5.3.1 Signal Input Interface	10
5.3.2 LED Driver Unit	12
5.4 Color Data Reference	12
5.5 Input Timing Chart	14
6.0 Pixel Format Image	15
7.0 Outline Dimensions	15
8.0 Labeling, Packaging & Others	18
9.0 General Notices	19
9.1 Storage	19
9.2 Operation & Others	20



1.0 Handling Precaution

- 1.) Handle with care. Pay attention not to press or scratch the surface of the monitor, especially the polarizer. Do not twist or bend the monitor. It may cause un-recoverable damage .
- 2.) Do not drop or bump the monitor since this monitor contains fragile glass components. Breakage of this monitor might cause leakage of the liquid crystal sealed inside the monitors. Do not touch the liquid crystal liquid in case of leakage. Flush with massive water immediately in case of contact with your skin with liquid crystal fluid and call for doctor for immediate medical treatment.
- 3.) Be sure to turn off power supply while plug or un-plug the power input connector.
- 4.) Clean up the polarizer only with soft solvent if necessary. The desirable cleaners are water, IPA(Isopropyl Alcohol) or Hexane. Do not use Ketone type materials (ex. Acetone), Ethyl alcohol, toluene, Ethyl acid or Methyl chloride. It will permanently damage the polarizer due to chemical reaction.
- 5.) Wipe off fluid drop immediately to prevent from possible discoloration or spots on the polarizer.
- 6.) Do not twist nor bend the monitor structure, even momentarily. Bending or twisting torque may likely damage the internal components of the monitor.
- 7.) Protect the monitor from static environment to prevent from damage to the CMOS gate array IC.



2.0 General Description

T043W1D1 is a 4.3 inch color active matrix TFT LCD monitor with slim body design and excellent display performance driven by a pure **DIGITAL** CMOS interface. This monitor supports true **WQVGA**, 480(H) x RGB x 272(V), stripe screen format and 16.7M colors (RGB 24 bits data). It uses **LEDs**(Light Emitting Diodes) as its luminous source and is able to reach **400(typ.)** nits ultra-high brightness at low level power consumption within the slim body. This makes T043W1D1 an excellent solution for the mobile terminal of outdoor video applications and for aviation industry. With its **ALL-IN-ONE** functionality, including a built-in DC-DC power module for LEDs and signal circuitry, T043W1D1 is a designer friendly and cost effective product.

2.1 General Applications

- Mobile Display Terminal for GPS, Gaming, Video, Industrial and Medical Applications

2.2 Main Features

- Slim Structure Design
- Good brightness, 400 nits
- Wide Viewing Angle
- Low Power Consumption with LED Backlight & Built-in LED Driver
- Pure Digital CMOS Interface & Built-in DC-DC

2.3 General Information

2.3.1 Display Characteristics

Item	Specification	Unit	Note
Display Area	95.04(H) x 53.86(V) (Diagonal)	mm	-
Driver Element	a-Si TFT Active Matrix	-	-
Number of Pixels	480(H) x 272(V)	pixel	WQVGA
Pixel Arrangement	RGB Vertical Stripe	-	-
Pixel Pitch	0.066x3 (H) x 0.198(V)	mm	Pixel
Display Mode	Normally White	-	-
Viewing Angle	140/120	degree	6 o'clock
Signal Interface	digital RGB 24 bits		16.7M colors

2.3.2 Mechanical Dimensions

Item	Min.	Typ.	Max.	Unit	Note
Dimension	Horizontal	-	107.6	mm	±0.5 mm
	Vertical	-	70.6		±0.5 mm
	Depth	-	5.8		±0.5 mm
Weight	-	75	-	g	±5g

3.0 Absolute Maximum Ratings

3.1 Absolute Ratings of Environment Requirement

Item	Symbol	Min.	Max.	Unit	Note
Storage Temperature	Tstg	-30	85	°C	(1)
Operation Temperature (Ambient Temperature)	Topr	-20	70	°C	(1)

Note (1) Temperature and relative humidity range are shown in the figure below.

95% RH Max. ($40^{\circ}\text{C} > T_a$)

Maximum wet – bulb temperature at 39°C or less. ($T_a > 40^{\circ}\text{C}$) No condensation.

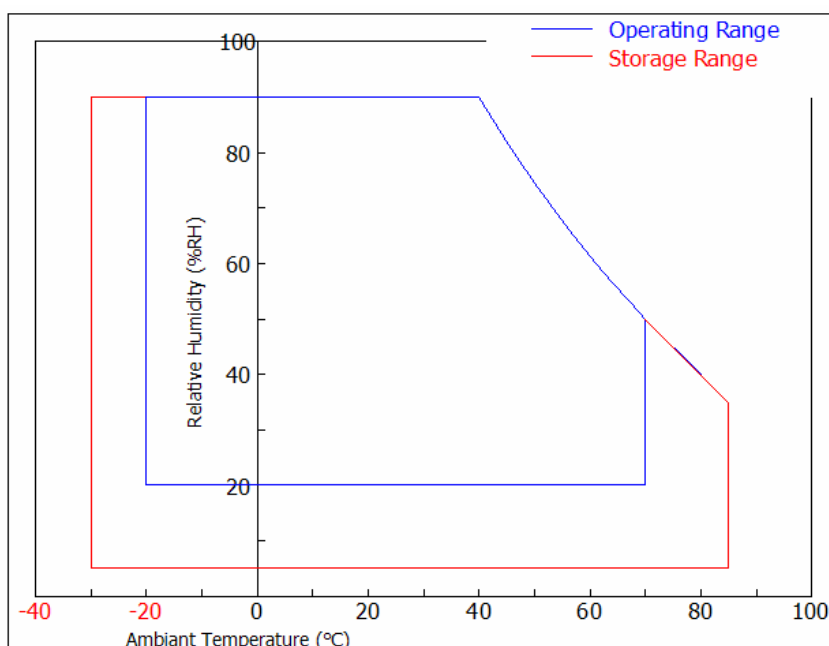

3.2 Electrical Absolute Ratings

3.2.1 TFT-LCD Module

($T_a = 25 \pm 2^{\circ}\text{C}$), $V_{gnd} = GND = 0V$)

Item	SYMBOL	Min.	Max.	UNIT	NOTE
Power Supply Voltage for Logic	V_{DD}	-0.3	4.0	V	(1),(2)
Input Voltage	V_{i1}	-0.3	4.0	V	(1),(2),(3)
Power Supply Voltage for LED	V_{LED}	-0.3	15	V	(1),(2)

Note (1) Within operating temperature

Note (2) Permanent damage to the device may occur if maximum values are exceeded. Functional operation should be restricted to the conditions described under normal operating conditions.

Note (3) For all pins except power and ground pins

4.0 Optical Characteristics

The following items are measured under stable conditions in a dark room or equivalent state.

* Measuring Equipment: BM-5A, PR-650

($V_{DD}=5V$, $f_V=60Hz$, $T_a=25\pm 2^\circ C$)

Item	Symbol	Condition	Min.	Typ.	Max.	Unit	Note
Contrast Ratio	CR	$\Phi=0$	400	500	-		BM-5A (4)-[1]
Response Time at 25°C	Rising	$\theta=0$	-	10	20	ms	BM-5A (5)
	Falling	Viewing Normal Angle	-	15	30		
Luminance	Y_L	Viewing Normal Angle	-	400	-	cd/m ²	BM-5A (4)-[2]
Luminance Uniformity	δ_w		70	75		%	(8)
Viewing Angle	Hor.	θ_L		70		Degree	BM-5A (7)
		θ_R	CR ≥ 10 (at center point)		70		
	Ver.	θ_H		50			
		θ_L		70			

Note (1) : Ambient temperature =25°C, and , using the Mode 2 of LED control scheme and $V_{DIM} =0V$ to get the maximum brightness. To be measured in the dark room.

Note (2) If product is exposed to high temperatures for extended time, there is a possibility of the polarizer file damage which could degrade the optical characteristics.

Note (3) Test Equipment Setup

After leaving the panel alone at a given temperature for 30 minutes under a stable condition, the measurement should be executed. Measurement should be executed in a stable, windless and dark room over 30 minutes after the backlight is lighted up. The measuring point should be at the center of screen.

-Environment condition : $T_a=25\pm 2^\circ C$

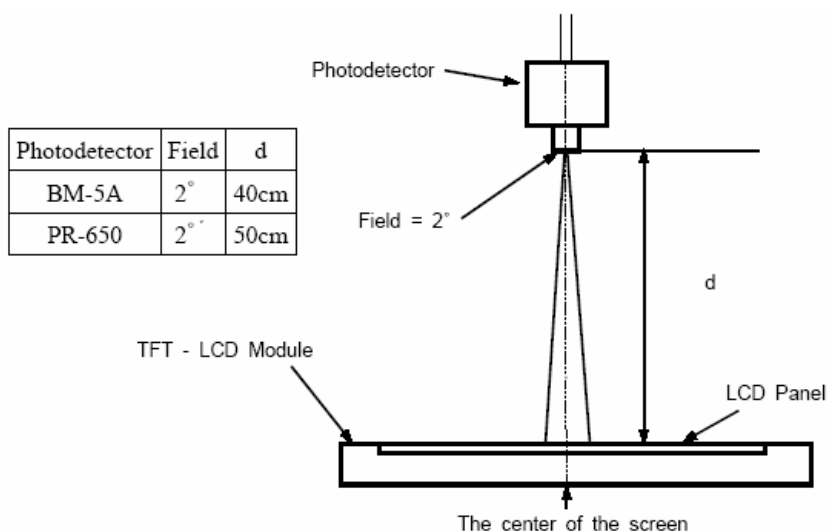

Note (4) Definition of Contrast Ratio, Luminance

[1] Definition of Contrast Ratio (CR) : Ratio of gray max (Gmax), gray min (Gmin) at 5 point.

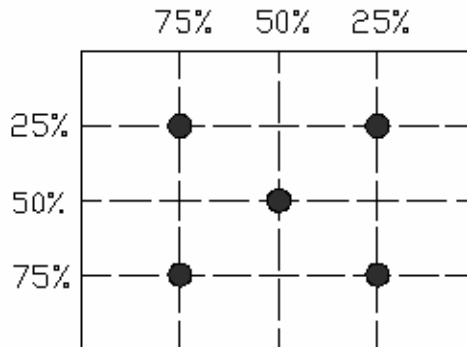

$$C/R = G_{max}/G_{min}$$

G_{max} : Luminance with all pixels white

G_{min} : Luminance with all pixels black

[2] Definition of Luminance : measure the luminance of white at center point when LCD is electronically opened.

Note (5) Definition of Response Time : Sum of T_r and T_f .

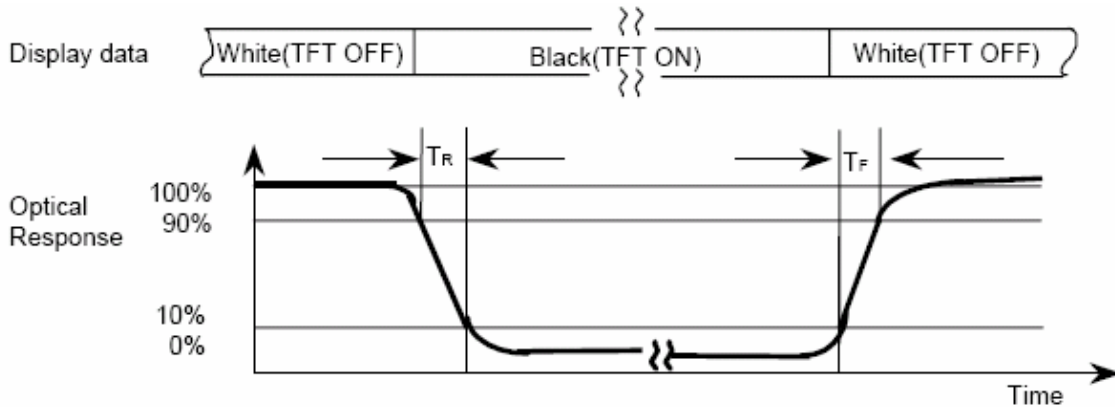

Note (6) Definition of Color Chromaticity (CIE 1931), (Backlight : ON) :

Color coordinate of white at the center point

Note (7) Definition of Viewing Angle : Viewing angle range ($CR \geq 10$)

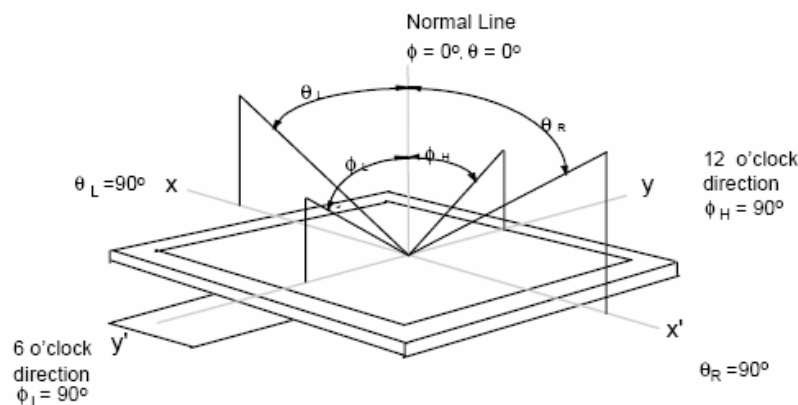

Note (8) : Definition of White Uniformity :

Luminance is measured at the above 5 points.

$$\delta_w = \text{Minimum Brightness of 5 points} / \text{Maximum Brightness of 5 points}$$

5.0 Electrical Characteristics

5.1 AC Timing Characteristics

Signal	Item	Symbol	Min.	Typ.	Max.	Unit	Note
LVDS Clock	Frequency	Fc	7	9	12	MHz	-
	Period	Tc	142.9	111.1	83.3	ns	
Vertical Active Display Term	Frame Rate	Fr		60		Hz	
	Total	Tv	277	288	400	Th	Tv=Tvd+Tvb
	Display	Tvd	272	272	272	Th	-
	Blank	Tvb	5	16	128	Th	-
Horizontal Active Display Term	Total	Th	520	525	800	Tc	Th=Thd+Thb
	Display	Thd	480	480	480	Tc	-
	Blank	Thb	40	45	320	Tc	-
Data to Clock	Setup time	Tds	10			ns	
	Hold time	Tdf	10			ns	

5.2 DC Characteristics

5.2.1 TFT-LCD Module

Item	Symbol	Min.	Typ.	Max.	Unit	Note
Supply Voltage	V _{DD}	3.0	3.3	3.6	V	(1)
	I _{DD}	-	20		mA	(2))
Permissive Input Ripple Voltage	V _{RF}	-	-	100	mV _{P-P}	V _{DD} =3.3V
Input Voltage (Low)	V _{IL}	0	-	0.2 V _{DD}	V	(3)
Input Voltage (High)	V _{IH}	0.8 V _{DD}	-	V _{DD}	V	(3)
Input Current (Low)	I _{IL}	-	-	10	μA	(3)
Input Current (High)	I _{IH}	-	-	10	μA	(3)

Note (1) VDD Power-On condition :

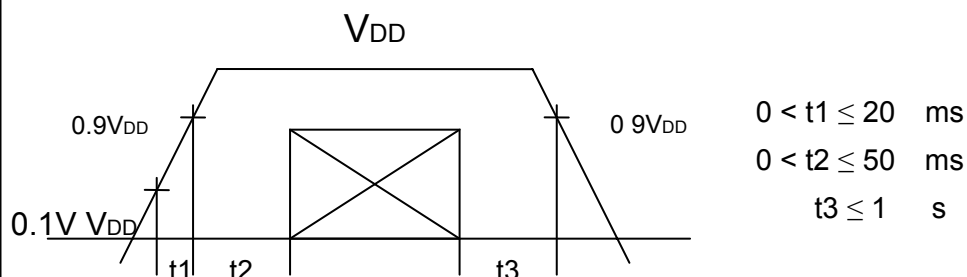

Note (2) Conditions for current consumption :

8 Gray Scale Pattern, V_{CC}=3.3V, f_V=60Hz,

Note (3) CLK, DE, R0~R7, G0~G7, B0~B7

5.2.2 DC-DC for LED Backlight

Item	Symbol	Min.	Typ.	Max.	Unit	Note
Supply Voltage	V_{LED}	10.8	12	13,2	V	
	I_{LED}		75	mA		Note1

Note 1 $V_{BL} = 12V$, using the Mode 2 of LED control scheme and $V_{DIM} = 0V$ to get the maximum

Note 2 : V_{BL} Power-On Condition for LED driver :

Please make sure the control signals must arrive after the power supply of LED driver, V_{BL} .

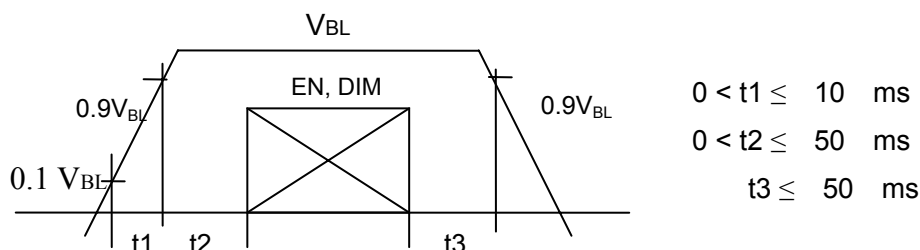

5.3 Input Terminal Pin Assignment

5.3.1 Signal Input Interface

40 pin FFC Tail with 0.5mm pitch

Matching Connector: Hirose FH19SC-40-0.5SH or equivalent

Pin No	Symbol	Description	Remark
1	NC	No Connection	-
2	NC	No Connection	-
3	GND	Power ground	-
4	VCC	Power supply Voltage (+3.3V)	-
5	R0	Red data input(LSB)	-
6	R1	Red data input	-
7	R2	Red data input	-
8	R3	Red data input	-
9	R4	Red data input	-
10	R5	Red data input	-
11	R6	Red data input	-
12	R7	Red data input(MSB)	-
13	G0	Green data input(LSB)	-
14	G1	Green data input	-
15	G2	Green data input	-
16	G3	Green data input	-
17	G4	Green data input	-
18	G5	Green data input	-



19	G6	Green data input	-
20	G7	Green data input(MSB)	-
21	B0	Blue Data (LSB)	
22	B1	Blue Data	
23	B2	Blue Data	
24	B3	Blue Data	
25	B4	Blue Data	
26	B5	Blue Data	
27	B6	Blue Data	
28	B7	Blue Data (MSB)	
29	GND	Power ground	
30	CLK	Data Clock	
31	DISP_ON	Display ON/Off control input	
32	NC	No Connection	
33	NC	No Connection	
34	DE	Data Enable	
35	NC	No Connection	
36	GND	Power ground	
37	NC	No Connection	
38	NC	No Connection	
39	NC	No Connection	
40	NC	No Connection	

5.3.2 LED Driver Unit

Connector : DF13-5P-1.25DSA20

Matching Connector : DF13-5S-1.25(xx)

Mode 1

Pin No.	Symbol	Description	Remark
1	V _{BL}	Power Supply for LED Driver	
2	EN	LED Enable & Dimming Control Input	Note 1
3	DIM	Connect this pin to GND at this mode	Note 2
4	GND	Ground Pin for LED Driver	
5	GND	Ground Pin for LED Driver	

Note 1 : The “Enable & Dimming Control” of the LED driver shares the same pinning.

The LED backlight will turn on when the input voltage of this pin exceeds +0.6V.

The LED current/brightness will be adjustable by applying an analog voltage between +0.8 ~ +1.4V(Max. Brightness).

Note 2: The “DIM” pin should be connected to GND in order to get the full brightness.



Mode 2:

Pin No.	Symbol	Description	Remark
1	V _{BL}	Power Supply for LED Driver	
2	EN	LED Enable Control Input	Note 1
3	DIM	Dimming Control Input	Note 2
4	GND	Ground Pin for LED Driver	
5	GND	Ground Pin for LED Driver	

Note 1 : Disable V_{EN}<0.6 V, Enable V_{EN}>1.8 V

Note 2 : Max Brightness V_{DIM} : 0V, Min Brightness V_{DIM} : 2.2V (≈ 0 Nit)

Mode 3:

Pin No.	Symbol	Description	Remark
1	V _{BL}	Power Supply for LED Driver	
2	EN	PWM Control Pulse Input	Note 1, 2
3	DIM	Connect this pin to GND at this mode	Note 3
4	GND	Ground Pin for LED Driver	
5	GND	Ground Pin for LED Driver	

Note 1: Valley of PWM Pulse V_{PWM}<0.6 V, Peak of PWM Pulse V_{PWM} >1.8 V

Note 2: The frequency of each completed PWM cycle: 100~300 Hz

Note 3: The “DIM” pin should be connected to GND in order to get the full brightness.

5.4 Color Data Reference

The below table is about input signal, Basic display colors and gray scale of each color.

0 : Low Level Voltage 1 : High Level Voltage

Each basic color can be displayed in 128 gray scales from 8 bit data signals. With the combination of total 24 bit data signals, the 16.7M color display can be achieved on the screen.

Please see the next page



	Colors & Gray Scale	Data Signal																								
		Gray Scale	R0	R1	R2	R3	R4	R5	R6	R7	G0	G1	G2	G3	G4	G5	G6	G7	B0	B1	B2	B3	B4	B5	B6	B7
Basic Color	Black	-	0	0	0	0	0	0	0	0	0	0	0	0	0	0	0	0	0	0	0	0	0	0	0	0
	Blue	-	0	0	0	0	0	0	0	0	0	0	0	0	0	0	0	0	1	1	1	1	1	1	1	1
	Green	-	0	0	0	0	0	0	0	0	1	1	1	1	1	1	1	1	0	0	0	0	0	0	0	0
	Cyan	-	0	0	0	0	0	0	0	0	1	1	1	1	1	1	1	1	1	1	1	1	1	1	1	1
	Red	-	1	1	1	1	1	1	1	1	0	0	0	0	0	0	0	0	0	0	0	0	0	0	0	0
	Magenta	-	1	1	1	1	1	1	1	1	0	0	0	0	0	0	0	0	1	1	1	1	1	1	1	1
	Yellow	-	1	1	1	1	1	1	1	1	1	1	1	1	1	1	1	1	0	0	0	0	0	0	0	0
	White	-	1	1	1	1	1	1	1	1	1	1	1	1	1	1	1	1	1	1	1	1	1	1	1	1
Gray Scale of Red	Black	GS0	0	0	0	0	0	0	0	0	0	0	0	0	0	0	0	0	0	0	0	0	0	0	0	0
	↑	GS1	1	0	0	0	0	0	0	0	0	0	0	0	0	0	0	0	0	0	0	0	0	0	0	0
	Darker	GS2	0	1	0	0	0	0	0	0	0	0	0	0	0	0	0	0	0	0	0	0	0	0	0	0
	↑	↓					↓							↓								↓				
	↓	↓					↓							↓								↓				
	Brighter	GS253	1	0	1	1	1	1	1	1	0	0	0	0	0	0	0	0	0	0	0	0	0	0	0	0
	↓	GS254	0	1	1	1	1	1	1	1	0	0	0	0	0	0	0	0	0	0	0	0	0	0	0	0
	Red	GS255	1	1	1	1	1	1	1	1	0	0	0	0	0	0	0	0	0	0	0	0	0	0	0	0
Gray Scale of Green	Black	GS0	0	0	0	0	0	0	0	0	0	0	0	0	0	0	0	0	0	0	0	0	0	0	0	0
	↑	GS1	0	0	0	0	0	0	0	0	1	0	0	0	0	0	0	0	0	0	0	0	0	0	0	0
	Darker	GS2	0	0	0	0	0	0	0	0	0	1	0	0	0	0	0	0	0	0	0	0	0	0	0	0
	↑	↓					↓							↓								↓				
	↓	↓					↓							↓								↓				
	Brighter	GS253	0	0	0	0	0	0	0	0	1	0	1	1	1	1	1	1	0	0	0	0	0	0	0	0
	↓	GS254	0	0	0	0	0	0	0	0	0	1	1	1	1	1	1	1	0	0	0	0	0	0	0	0
	Green	GS255	0	0	0	0	0	0	0	0	1	1	1	1	1	1	1	1	0	0	0	0	0	0	0	0
Gray Scale of Blue	Black	GS0	0	0	0	0	0	0	0	0	0	0	0	0	0	0	0	0	0	0	0	0	0	0	0	0
	↑	GS1	0	0	0	0	0	0	0	0	0	0	0	0	0	0	0	0	1	0	0	0	0	0	0	0
	Darker	GS2	0	0	0	0	0	0	0	0	0	0	0	0	0	0	0	0	0	1	0	0	0	0	0	0
	↑	↓					↓							↓								↓				
	↓	↓					↓							↓								↓				
	Brighter	GS253	0	0	0	0	0	0	0	0	0	0	0	0	0	0	0	0	1	0	1	1	1	1	1	1
	↓	GS254	0	0	0	0	0	0	0	0	0	0	0	0	0	0	0	0	0	1	1	1	1	1	1	1
	Blue	GS255	0	0	0	0	0	0	0	0	0	0	0	0	0	0	0	0	1	1	1	1	1	1	1	1



5.5 Input Timing Chart

6.0 Pixel Format

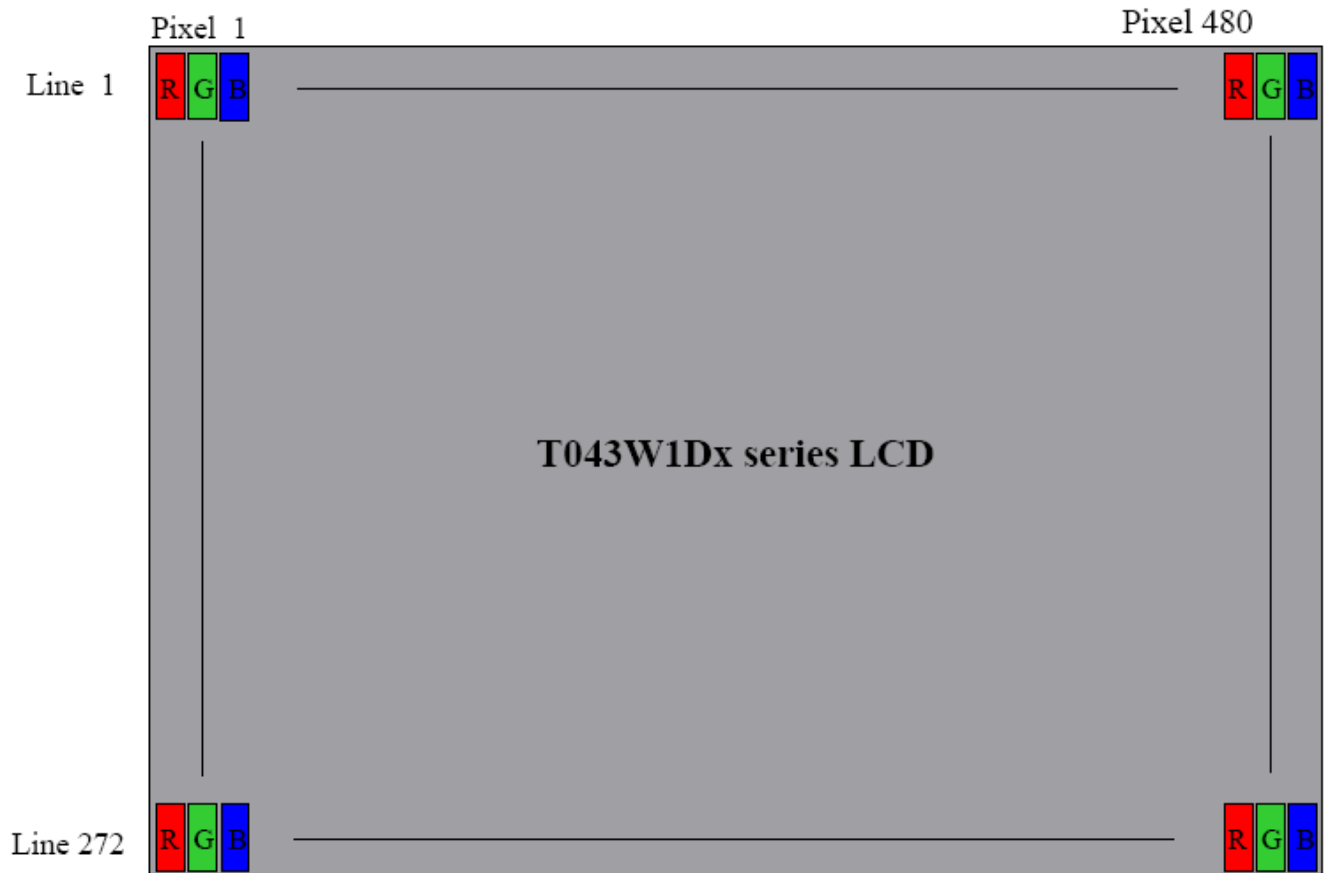

7.0 Outline Dimensions

7.1 Monitor Outline Dimensions

- Please refer to the next page





8.0 Labeling, Packaging & Others

* Labeling

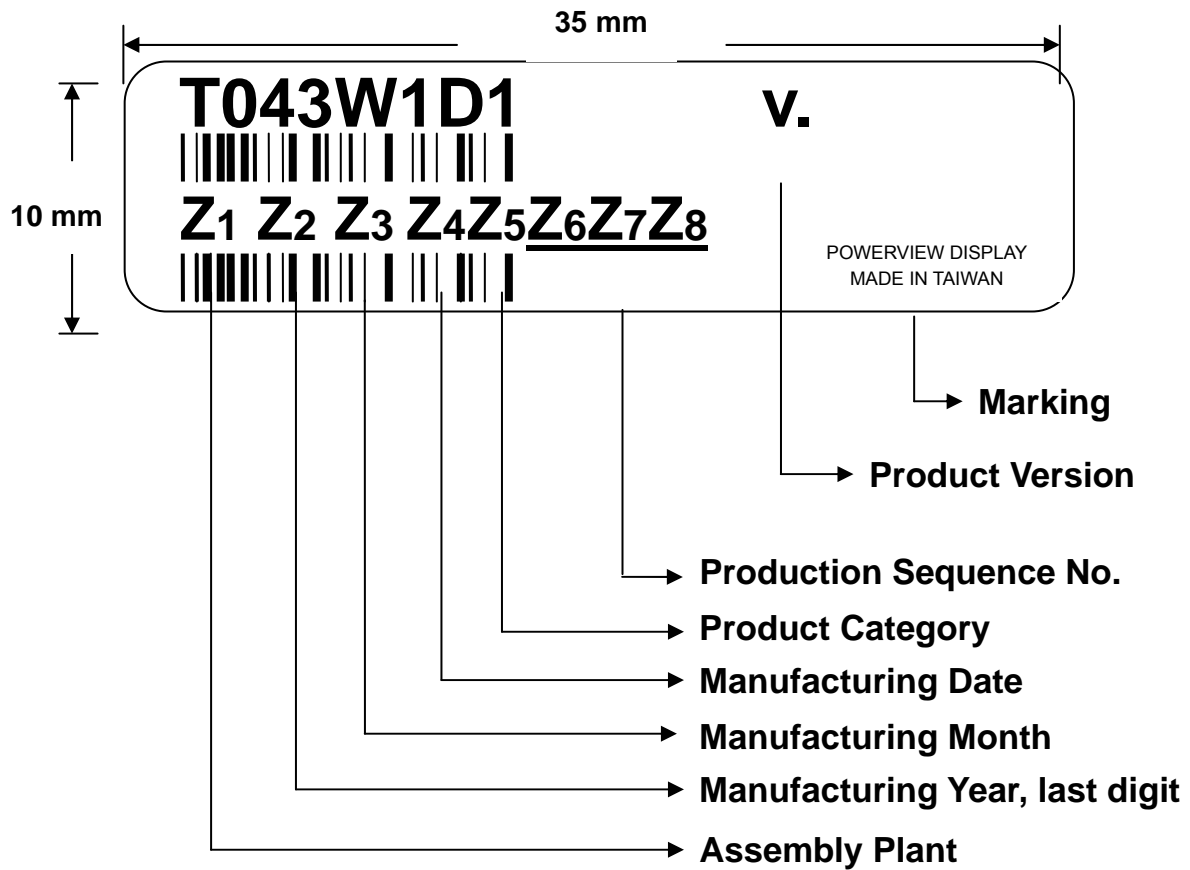

* Packaging

- TBD

* Others



9.0 General Notice

9.1 Reliability Test Items (Note 2)

No.	Test Items	Conditions	Remark
1	High Temperature Storage	Ta= + 85°C 240 Hrs	
2	Low Temperature Storage	Ta= - 30°C 240 Hrs	
3	High Temperature Operation	Ta= + 70°C 240 Hrs	
4	Low Temperature Operation	Ta= - 20°C 240 Hrs	
5	High Temperature and High Humidity	Tp= 60°C, 90%RH 240 Hrs	operation
6	Heat Shock	-30~85°C /200 cycles 1Hr/cycle	Non-operation
7	Electrostatic discharge	±200V, 200pF(0Ω), once for each terminal	Non-operation
8	Vibration	Frequency range : 8~33.3 Hz Stoke : 1.3mm Sweep : 2.9G, 33.3~400Hz Cycle : 15 minutes 2 hours for each direction of X,Z 4 hours for Y direction	JIS C7021, A-10 Condition A
9	Mechanical Shock	100G, 6ms, ±X±Y±Z 3 times for each direction	JIS C7021, A-7 Condition C
10	Vibration (with carton)	Random vibration : 0.015G ² /Hz from 5~200Hz -6dB/octave from 200~500Hz	IEC 68-34
11	Drop (with carton)	Height : 60 cm 1 corner, 3 edges, 6 surfaces	JIS Z0202

Note1: Ta: Ambient temperature.

Note 2: In the standard conditions, there is not display function NG issue occurred. All the cosmetic specification is judged before the reliability stress.



10.2 Storage, Operation & Others

- (a) Do not leave the panel in high temperature, and high humidity for a long time.
It is highly recommended to store the module with temperature from 0 to 35°C and relative humidity of less than 70%.
- (b) Do not store the TFT-LCD module in direct sunlight.
- (c) The module shall be stored in a dark place. It is prohibited to apply sunlight or fluorescent light during the store.
- (d) Do not connect, disconnect the module in the "Power On" condition.
- (e) Power supply should always be turned on/off by the item 3.2 "Electrical Absolute Ratings"
- (f) The liquid-crystal is deteriorated by ultraviolet rays. Do not leave it in direct sunlight and strong ultraviolet rays for many hours.
- (g) Avoid condensation of water. It may result in improper operation or disconnection of electrode.
- (h) Do not exceed the absolute maximum rating value. (the supply voltage variation, input voltage variation, variation in part contents and environmental temperature, and so on) Otherwise the panel may be damaged.
- (i) If the panel displays the same pattern continuously for a long period of time, it can be the situation when the image "Sticks" to the screen.
- (j) This panel has its circuitry FPC on the bottom side and should be handled carefully in order not to be stressed.