



Records of Revision

Date	Rev. No.	Summary	Page
2006/11/28	01	First issue of T035Q1D1 specification sheet	1



Contents	Page
1.0 Handling Precautions	4
2.0 General Description	5
2.1 General Application	5
2.2 Main Features	5
2.3 General Information	5
2.3.1 Display Characteristics	5
2.3.2 Mechanical Dimensions	5
3.0 Absolute Maximum Ratings	6
3.1 Absolute Ratings of Environment Requirement	6
3.2 Electrical Absolute Ratings	6
3.2.1 TFT-LCD Module	6
4.0 Optical Characteristics	7
5.0 Electrical Characteristics	10
5.1 AC Timing Characteristics	10
5.2 DC Characteristics	10
5.2.1 TFT-LCD Module	10
5.2.2 DC-DC for LED Backlight	11
5.3 Input Terminal Pin Assignment	12
5.3.1 Signal Input Interface	12
5.4 Color Data Reference	13
5.5 Input Timing Chart	14
6.0 Pixel Format Image	16
7.0 Outline Dimensions	16
8.0 Labeling, Packaging & Others	18
9.0 General Notices	19
9.1 Storage	19
9.2 Operation & Others	19



1.0 Handling Precaution

- 1.) Handle with care. Pay attention not to press or scratch the surface of the monitor, especially the polarizer. Do not twist or bend the monitor. It may cause un-recoverable damage .
- 2.) Do not drop or bump the monitor since this monitor contains fragile glass components. Breakage of this monitor might cause leakage of the liquid crystal sealed inside the monitors. Do not touch the liquid crystal liquid in case of leakage. Flush with massive water immediately in case of contact with your skin with liquid crystal fluid and call for doctor for immediate medical treatment.
- 3.) Be sure to turn off power supply while plug or un-plug the power input connector.
- 4.) Clean up the polarizer only with soft solvent if necessary. The desirable cleaners are water, IPA(Isopropyl Alcohol) or Hexane. Do not use Ketone type materials (ex. Acetone), Ethyl alcohol, toluene, Ethyl acid or Methyl chloride. It will permanently damage the polarizer due to chemical reaction.
- 5.) Wipe off fluid drop immediately to prevent from possible discoloration or spots on the polarizer.
- 6.) Do not twist nor bend the monitor structure, even momentarily. Bending or twisting torque may likely damage the internal components of the monitor.
- 7.) The cold cathode fluorescent lamp in LCD contains small amount of mercury (Hg). Please refer to the design specification for application and the local regulations and environmental laws for disposal purpose.
- 8.) Protect the monitor from static environment to prevent from damage to the CMOS gate array IC.



2.0 General Description

T035Q1D1 v.2 is a 3.5 inch color active matrix TFT LCD monitor with slim outlook and excellent display performance driven by a pure **DIGITAL** CMOS interface. This monitor supports true **QVGA**, 320(H) x RGB x 240(V), stripe screen format and 262,144 full colors (RGB 6 bits data). It uses **LEDs**(Light Emitting Diodes) as its luminous source and is able to reach **1200(typ.)** nits ultra-high brightness with very a very slim body. This makes T035Q1D1 v.2 very suitable for the terminal and video applications at outdoor. On the other hand, the power consumption for this high brightness is still maintained at low level, this make it as an excellent solution for mobile application. With its **ALL-IN-ONE** functionality, including a built-in DC-DC power module for LEDs and signal circuitry, T035Q1D1 v.2 is a designer friendly and cost effective product.

2.1 General Applications

- Mobile Display Terminal for GPS, Gaming, Video, Industrial and Medical Applications

2.2 Main Features

- Very Slim Structure Design
- Ultra High brightness
- Wide Viewing Angle
- Low Power Consumption with LED Backlight
- Pure Digital CMOS Interface
- Built-in DC-DC

2.3 General Information

2.3.1 Display Characteristics

Item	Specification	Unit	Note
Display Area	70.08(H) x 52.56(V) (Diagonal)	mm	-
Driver Element	a-Si TFT Active Matrix	-	-
Number of Pixels	320(H) x 240(V)	pixel	QVGA
Pixel Arrangement	RGB Vertical Stripe	-	-
Dot Pitch	0.073x3 (H) x 0.219(V)	mm	Dot
Display Mode	Normally White	-	-
Viewing Angle	130/120	degree	6 o'clock
Signal Interface	digital RGB 18 bits		262k colors

2.3.2 Mechanical Dimensions

Item		Min.	Typ.	Max.	Unit	Note
Dimension	Horizontal	-	78.2	-	mm	±0.5 mm
	Vertical	-	65.0	-		±0.5 mm



	Depth	-	6.72	-		±0.5 mm
	Weight	-	68	-	g	±5g

3.0 Absolute Maximum Ratings

3.1 Absolute Ratings of Environment Requirement

Item	Symbol	Min.	Max.	Unit	Note
Storage Temperature	Tstg	-30	85	°C	(1)
Operation Temperature (Ambient Temperature)	Topr	-30	85	°C	(1)

Note (1) Temperature and relative humidity range are shown in the figure below.

95% RH Max. ($40^{\circ}\text{C} > T_a$)

Maximum wet – bulb temperature at 39°C or less. ($T_a > 40^{\circ}\text{C}$) No condensation.

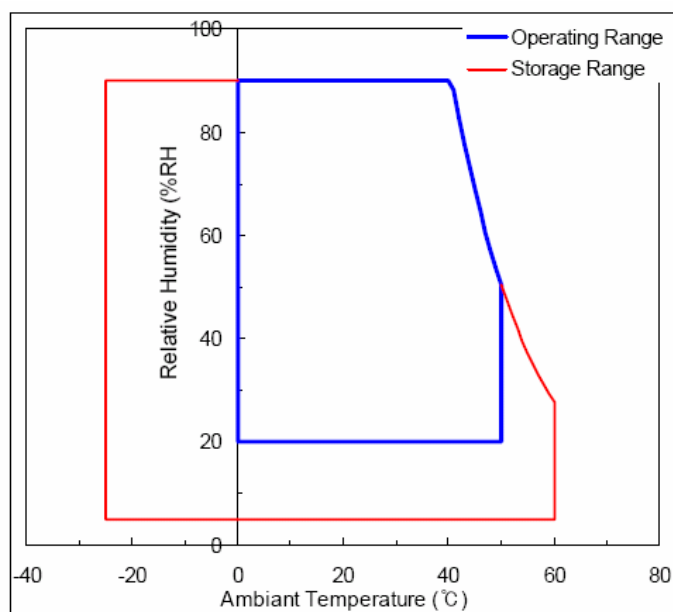

3.2 Electrical Absolute Ratings

3.2.1 TFT-LCD Module

($T_a = 25 \pm 2^{\circ}\text{C}$), $V_{gnd} = GND = 0V$)

Item	SYMBOL	Min.	Max.	UNIT	NOTE
Power Supply Voltage for Logic	V_{DD}	-0.3	4.0	V	(1),(2)
Input Voltage	V_{i1}	-0.3	4.0	V	(1),(2),(3)
Power Supply Voltage for LED	V_{LED}	-0.3	15	V	(1),(2)

Note (1) Within operating temperature

Note (2) Permanent damage to the device may occur if maximum values are exceeded.



Functional operation should be restricted to the conditions described under normal operating conditions.

Note (3) For all pins except power and ground pins

4.0 Optical Characteristics

The following items are measured under stable conditions in a dark room or equivalent state.

* Measuring Equipment: BM-5A, PR-650

($V_{DD}=5V$, $f_V=60Hz$, $f_H=15.734KHz$, $T_a=25\pm 2^\circ C$)

Item	Symbol	Condition	Min.	Typ.	Max.	Unit	Note	
Contrast Ratio	CR	$\Phi=0$ $\theta=0$ Viewing Normal Angle	200	300	-		BM-5A (4)-[1]	
Response Time at 25°C	Rising		T_R	-	15	30	ms	BM-5A (5)
	Falling		T_F	-	20	50		
Luminance	Y_L		-	1200	-	cd/m ²	BM-5A (4)-[2]	
Color Chromaticity	W_X		TBD					
	W_Y	TBD						
Viewing Angle	Hor.	θ_L	CR ≥ 10 (at center point)	65	Degree		BM-5A (7)	
		θ_R		65				
	Ver.	θ_H		45				
		θ_L		65				

Note (1) The optical characteristics is measured with backlight.

Note (2) If product is exposed to high temperatures for extended time, there is a possibility of the polarizer file damage which could degrade the optical characteristics.

Note (3) Test Equipment Setup

After leaving the panel alone at a given temperature for 30 minutes under a stable condition, the measurement should be executed. Measurement should be executed in a stable, windless and dark room over 30 minutes after the backlight is lighted up. The measuring point should be at the center of screen.

-Environment condition : $T_a=25\pm 2^\circ C$

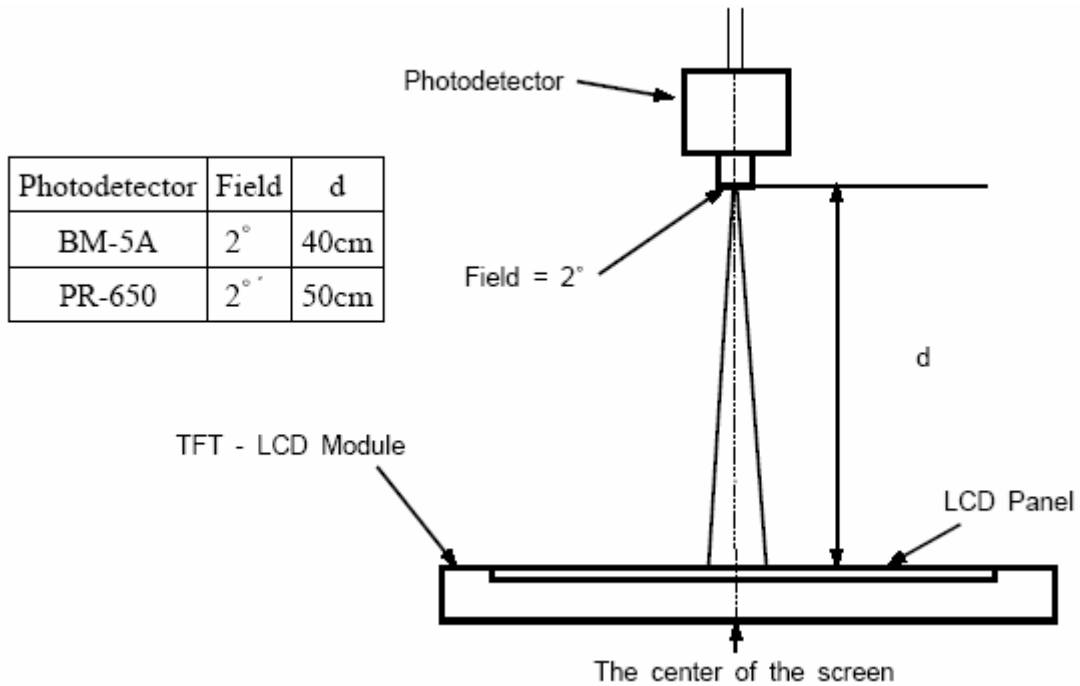

Note (4) Definition of Contrast Ratio, Luminance

ACTIVE AREA (H:101.76mm/ V:76.36mm)

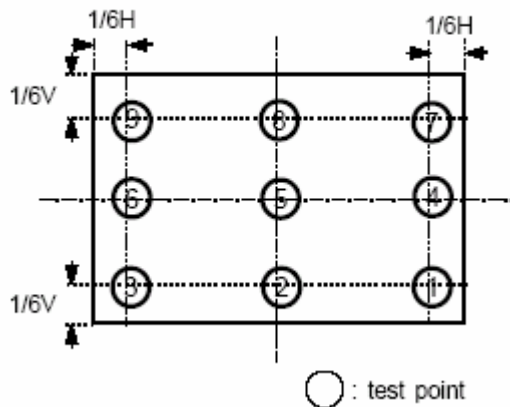

[1] Definition of Contrast Ratio (CR) : Ratio of gray max (G_{max}), gray min (G_{min}) at 9 points.

$$C/R = G_{max}/G_{min}$$

G_{max} : Luminance with all pixels white

G_{min} : Luminance with all pixels black

[2] Definition of Luminance : measure the luminance of white at center point and with I_{CCFL}=6.0mA

Note (5) Definition of Response Time : Sum of T_r and T_f.

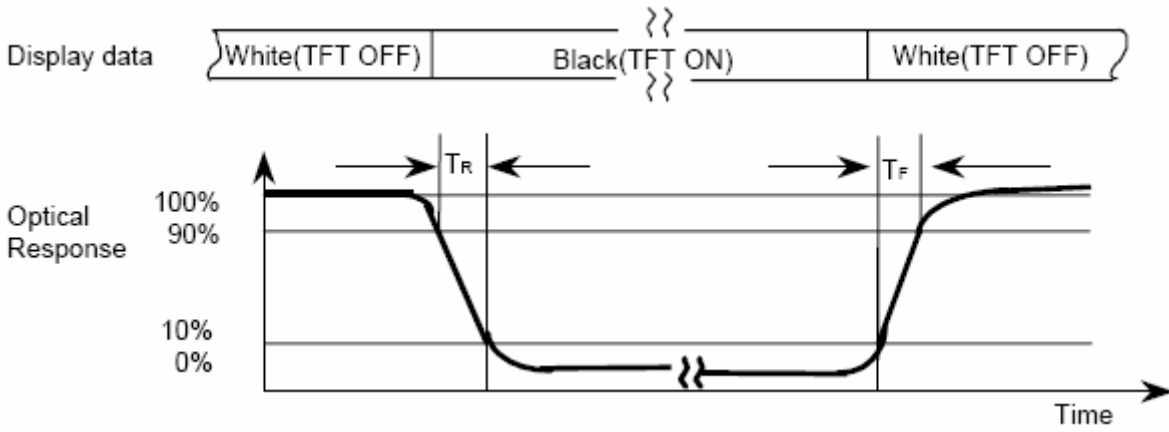

Note (6) Definition of Color Chromaticity (CIE 1931), (Backlight : ON) :
Color coordinate of white at the center point

Note (7) Definition of Viewing Angle : Viewing angle range ($CR \geq 10$)

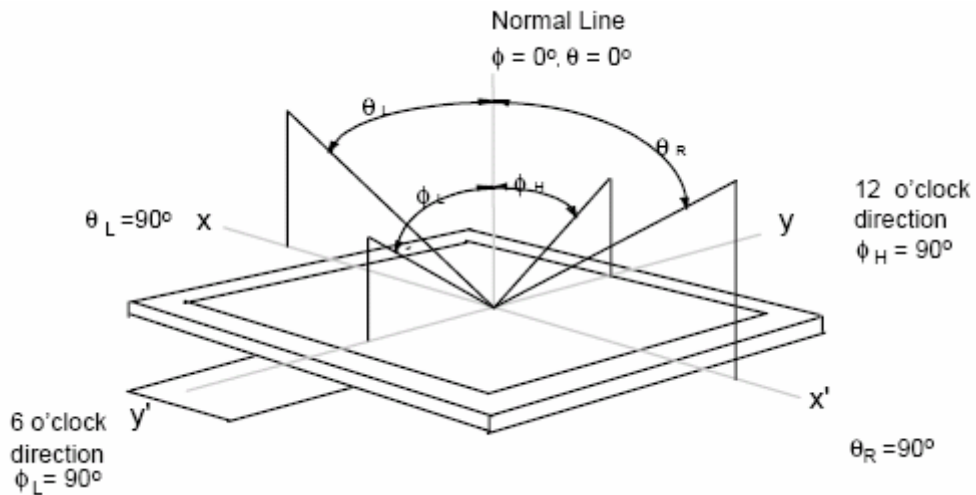



5.0 Electrical Characteristics

5.1 AC Timing Characteristics

Item	Symbol	Min.	Typ.	Max.	Unit	Note
Clock Frequency	F_{ck}	5.5	6.25	7	MHz	
Clock Duty Ratio	$T_{ch}/(T_{ch}+T_{cl})$	40	50	60	%	
Hsync Period	T_h	390	392	450	clk	
	τ_h	60	63.5	67	μs	$\tau_h = F_{ck} \times T_h$
Hsync Pulse Width	T_{hw}	2	16	32	clk	
Vsync Period	T_v	258	262	280	T_h	
	τ_v	16.1	16.6	17.1	ms	$\tau_v = \tau_h \times T_v$
Vsync Pulse Width	T_{vw}	2	4	16	T_h	
Hsync/Vsync Phase Shift	T_{vpd}	2	-	-	clk	
Horizontal Display Start	T_{he}	(69)	(69)	(69)	clk	
Vertical Display Start	T_{ve}	(17)	(17)	(17)	T_h	
Hsync Clock Shift	T_{hc}	10	-	-	ns	
Data Setup Time	T_{ds}	5	-	-	ns	
Data Hold Time	T_{dh}	10	-	-	ns	

5.2 DC Characteristics

5.2.1 TFT-LCD Module

Item	Symbol	Min.	Typ.	Max.	Unit	Note
Supply Voltage	V_{DD}	3.0	3.3	3.6	V	(1)
	I_{DD}	-	110	110	mA	(2)(4)
Permissive Input Ripple Voltage	V_{RF}	-	-	100	mV _{P-P}	$V_{DD}=+5V$
Input Voltage (Low)	V_{IL}	0	-	0.3	V	(3)
Input Voltage (High)	V_{IH}	0.7	-	5.5	V	(3)
Input Current (Low)	I_{IL}	-	-	10	μA	(3)
Input Current (High)	I_{IH}	-	-	10	μA	(3)

Note (1) VDD Power-On condition :

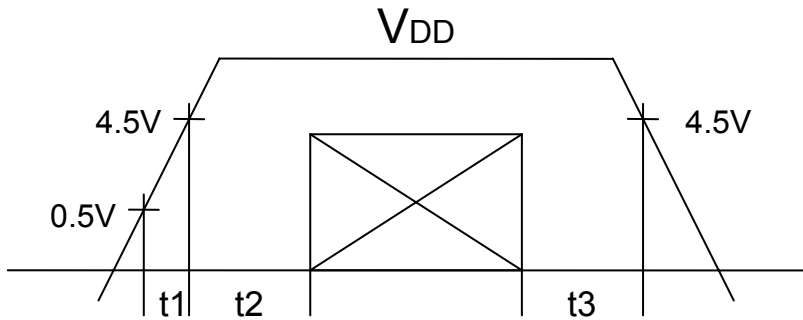

$$0 < t1 \leq 20 \text{ ms}$$

$$0 < t2 \leq 50 \text{ ms}$$

$$t3 \leq 1 \text{ s}$$

Note (2) Conditions for current consumption :

8 Gray Scale Pattern, $V_{CC}=5.0V$, $f_H=15.3K$, $f_V=58.4Hz$, $f_{CLK}=6.0MHz$

Note (3) CLK, Hsync, Vsync, R0~R5, G0~G5, B0~B5

Note (4) LED current is included.

5.2.2 DC-DC for LED Backlight

Item	Symbol	Min.	Typ.	Max.	Unit	Note
Supply Voltage	V_{LED}	10.8	12	13,2	V	
	I_{LED}		128	mA		@1200 nits
Dimming Voltage	V_{dim}	1,0		1.5	V	(1)(2)(3)

Note (1) Brightness Dimming Control Scheme : Linear Analog Voltage Control

Note (2) When V_{dim} is less than 0.5V, LED will be shut down completely

Note (3) The Brightness of LED is adjusted from 0% to 100% by applying V_{dim} from 1.0V to 1.5V accordingly.



5.3 Input Terminal Pin Assignment

5.3.1 Signal Input Interface

Kyocera Elco Connector : 33 FFC/FPC Type : 08-6210-033-340-800

Pin No	Symbol	Description	Remark
1	GND	Ground	-
2	CLK	Data Clock	-
3	Hsync	Horizontal Sync.	-
4	Vsync	Vertical Sync.	-
5	GND	Ground	-
6	R0	Red Data (LSB)	-
7	R1	Red Data	-
8	R2	Red Data	-
9	R3	Red Data	-
10	R4	Red Data	-
11	R5	Red Data (MSB)	-
12	GND	Ground	-
13	G0	Green Data (LSB)	-
14	G1	Green Data	-
15	G2	Green Data	-
16	G3	Green Data	-
17	G4	Green Data	-
18	G5	Green Data (MSB)	-
19	GND	Ground	-
20	B0	Blue Data (LSB)	-
21	B1	Blue Data	-
22	B2	Blue Data	-
23	B3	Blue Data	-
24	B4	Blue Data	-
25	B5	Blue Data (MSB)	-
26	GND	Ground	-
27	DE	Data Enable	-
28	V _{DD}	Power Supply for Logic (+3.3V)	-
29	V _{DD}	Power Supply for Logic (+3.3V)	-
30	V _{LED}	Power Supply for LED Backlight(+12V)	-
31	V _{LED}	Power Supply for LED Backlight(+12V)	-
32	V _{Dim}	Dimming control for LED backlight	-
33	GND	Ground	-



5.4 Color Data Reference

The below table is about input signal, Basic display colors and gray scale of each color.

0 : Low Level Voltage 1 : High Level Voltage

Each basic color can be displayed in 64 gray scales from 6 bit data signals. With the combination of total 18 bit data signals, the 262k color display can be achieved on the screen.

Please see the next page



	Colors & Gray Scale	Data Signal																		
		Gray Scale	R0	R1	R2	R3	R4	R5	G0	G1	G2	G3	G4	G5	B0	B1	B2	B3	B4	B5
Basic Color	Black	-	0	0	0	0	0	0	0	0	0	0	0	0	0	0	0	0	0	0
	Blue	-	0	0	0	0	0	0	0	0	0	0	0	0	1	1	1	1	1	1
	Green	-	0	0	0	0	0	0	1	1	1	1	1	1	0	0	0	0	0	0
	Cyan	-	0	0	0	0	0	0	1	1	1	1	1	1	1	1	1	1	1	1
	Red	-	1	1	1	1	1	1	0	0	0	0	0	0	0	0	0	0	0	0
	Magenta	-	1	1	1	1	1	1	0	0	0	0	0	0	1	1	1	1	1	1
	Yellow	-	1	1	1	1	1	1	1	1	1	1	1	1	0	0	0	0	0	0
	White	-	1	1	1	1	1	1	1	1	1	1	1	1	1	1	1	1	1	1
Gray Scale of Red	Black	GS0	0	0	0	0	0	0	0	0	0	0	0	0	0	0	0	0	0	0
	↑	GS1	1	0	0	0	0	0	0	0	0	0	0	0	0	0	0	0	0	0
	Darker	GS2	0	1	0	0	0	0	0	0	0	0	0	0	0	0	0	0	0	0
	↑	↓				↓					↓						↓			
	↓	↓				↓					↓						↓			
	Brighter	GS61	1	0	1	1	1	1	0	0	0	0	0	0	0	0	0	0	0	0
	↓	GS62	0	1	1	1	1	1	0	0	0	0	0	0	0	0	0	0	0	0
	Red	GS63	1	1	1	1	1	1	0	0	0	0	0	0	0	0	0	0	0	0
Gray Scale of Green	Black	GS0	0	0	0	0	0	0	0	0	0	0	0	0	0	0	0	0	0	0
	↑	GS1	0	0	0	0	0	0	1	0	0	0	0	0	0	0	0	0	0	0
	Darker	GS2	0	0	0	0	0	0	0	1	0	0	0	0	0	0	0	0	0	0
	↑	↓				↓														
	↓	↓				↓														
	Brighter	GS61	0	0	0	0	0	0	1	0	1	1	1	1	0	0	0	0	0	0
	↓	GS62	0	0	0	0	0	0	0	1	1	1	1	1	0	0	0	0	0	0
	Green	GS63	0	0	0	0	0	0	1	1	1	1	1	1	0	0	0	0	0	0
Gray Scale of Blue	Black	GS0	0	0	0	0	0	0	0	0	0	0	0	0	0	0	0	0	0	0
	↑	GS1	0	0	0	0	0	0	0	0	0	0	0	0	1	0	0	0	0	0
	Darker	GS2	0	0	0	0	0	0	0	0	0	0	0	0	0	1	0	0	0	0
	↑	↓																		
	↓	↓																		
	Brighter	GS61	0	0	0	0	0	0	0	0	0	0	0	0	1	0	1	1	1	1
	↓	GS62	0	0	0	0	0	0	0	0	0	0	0	0	0	1	1	1	1	1
	Blue	GS63	0	0	0	0	0	0	0	0	0	0	0	0	1	1	1	1	1	1

5.5 Input Timing Chart

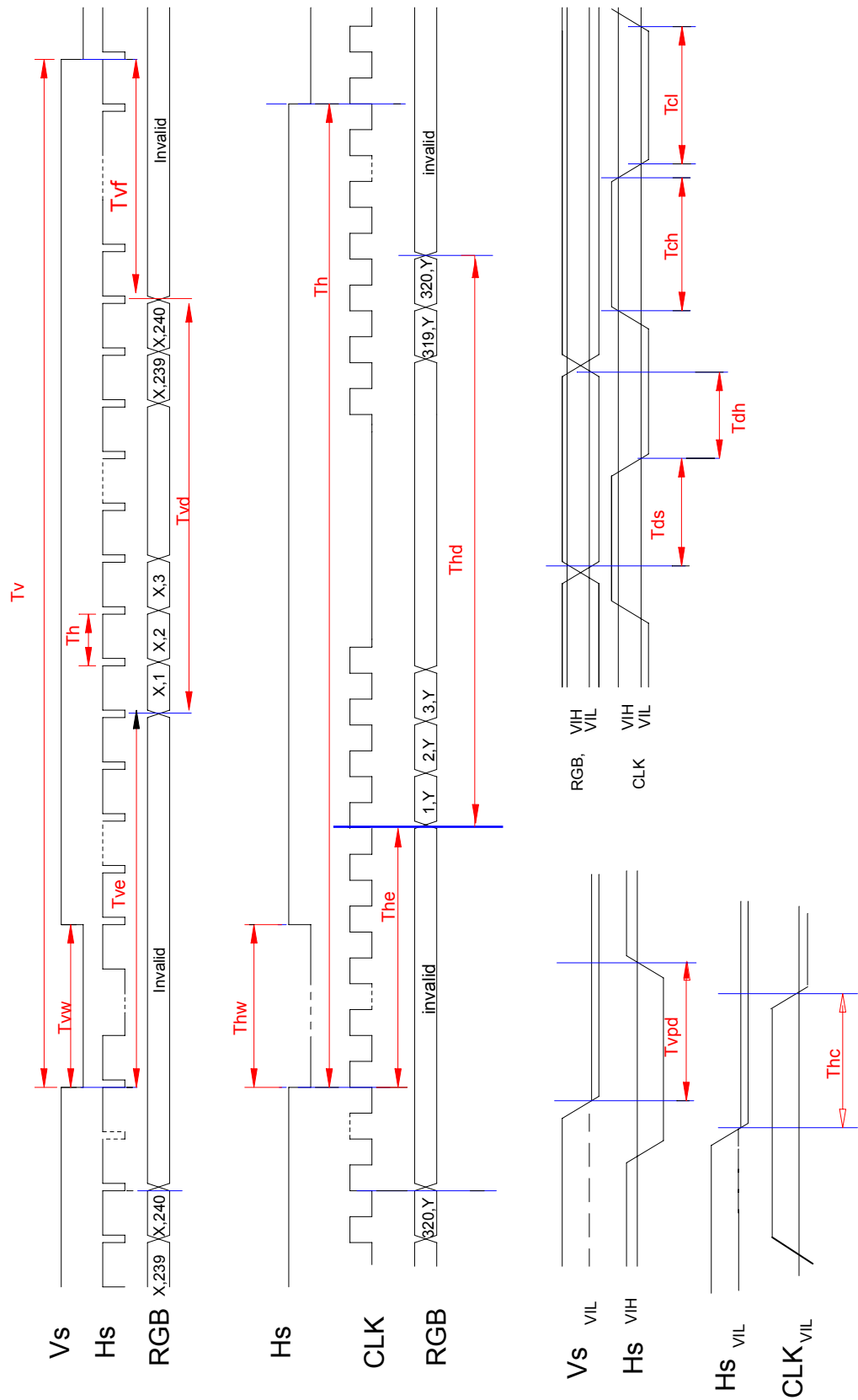

6.0 Pixel Format

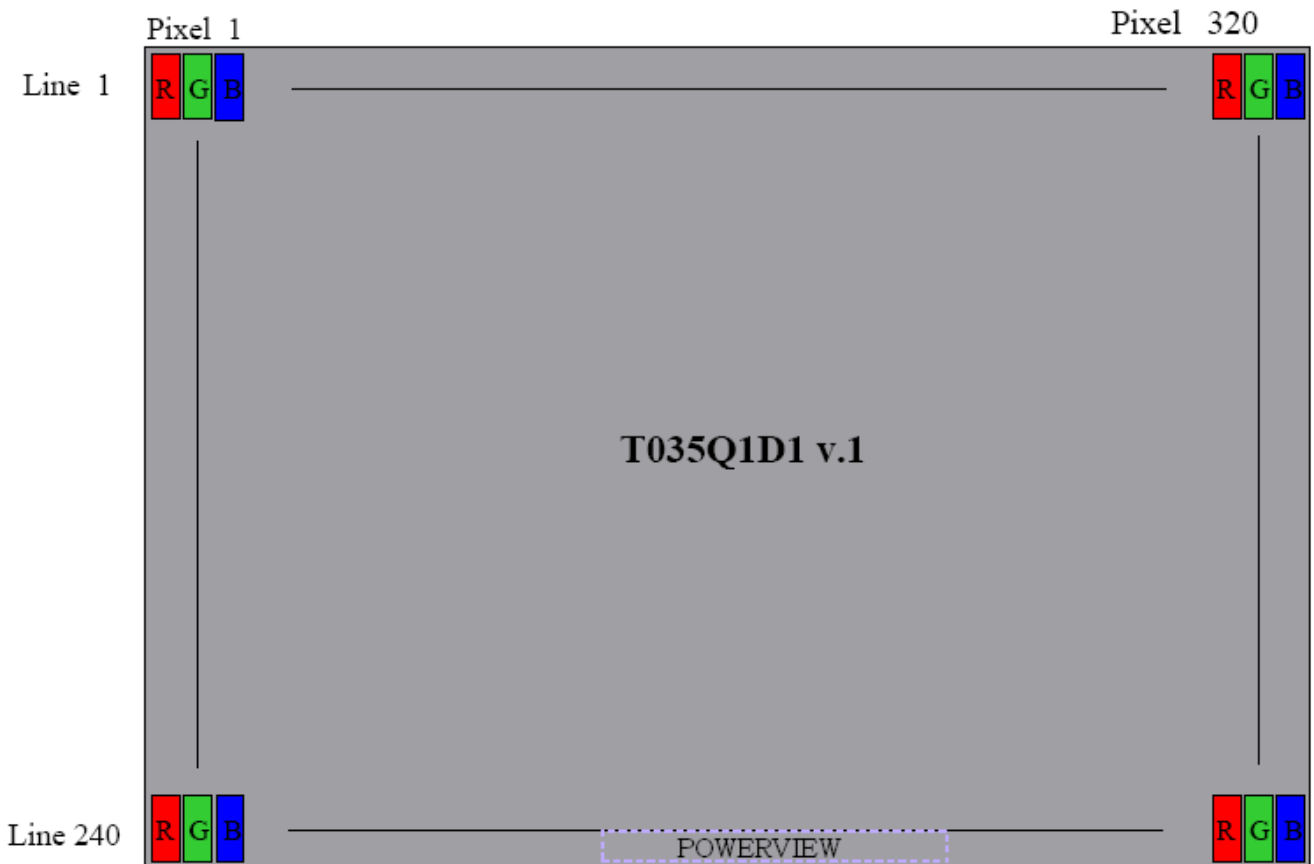

7.0 Outline Dimensions

7.1 Monitor Outline Dimensions

- Please refer to the next page

REV	EQ NUMBER	DESCRIPTION	DATE
1	X00000	X00000	2008/02/10

Notes :
 1. General Tolerance : ± 0.3 mm

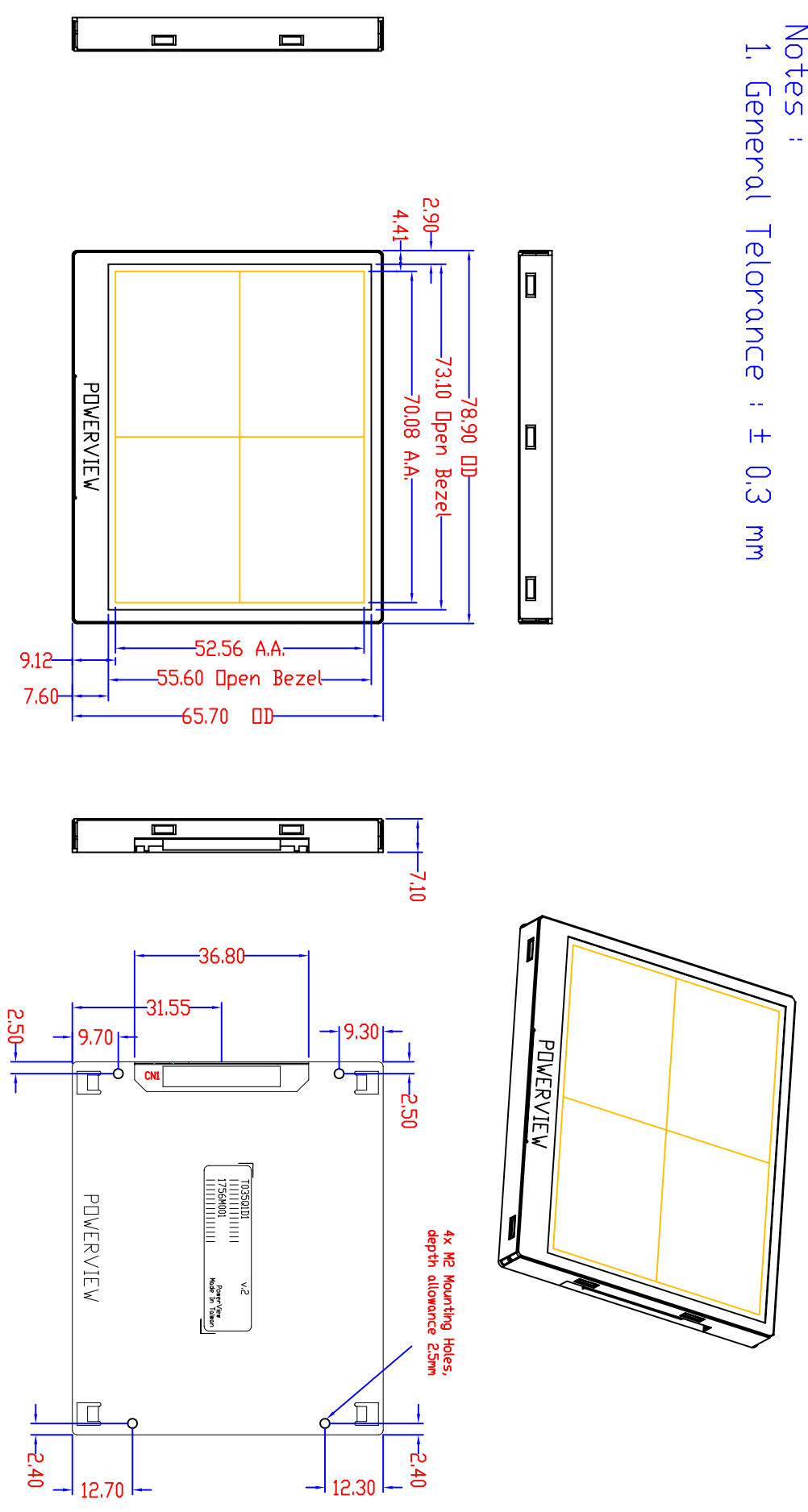

ITEM	DESCRIPTION	UNIT	QTY	REMARKS
1	GENERAL TOLERANCE	mm	±0.3	
2	FINISH			
3	CHECKED			
4	DESIGNED			
5	DATE			
6	BY			
7	CHKD			
8	DATE			
9	BY			
10	CHKD			
11	DATE			
12	BY			

ITEM	DESCRIPTION	UNIT	QTY	REMARKS
1	POWERVIEW	mm	1	
2	FINISH			
3	CHECKED			
4	DESIGNED			
5	DATE			
6	BY			
7	CHKD			
8	DATE			
9	BY			
10	CHKD			
11	DATE			
12	BY			

8.0 Labeling, Packaging & Others

* Labeling

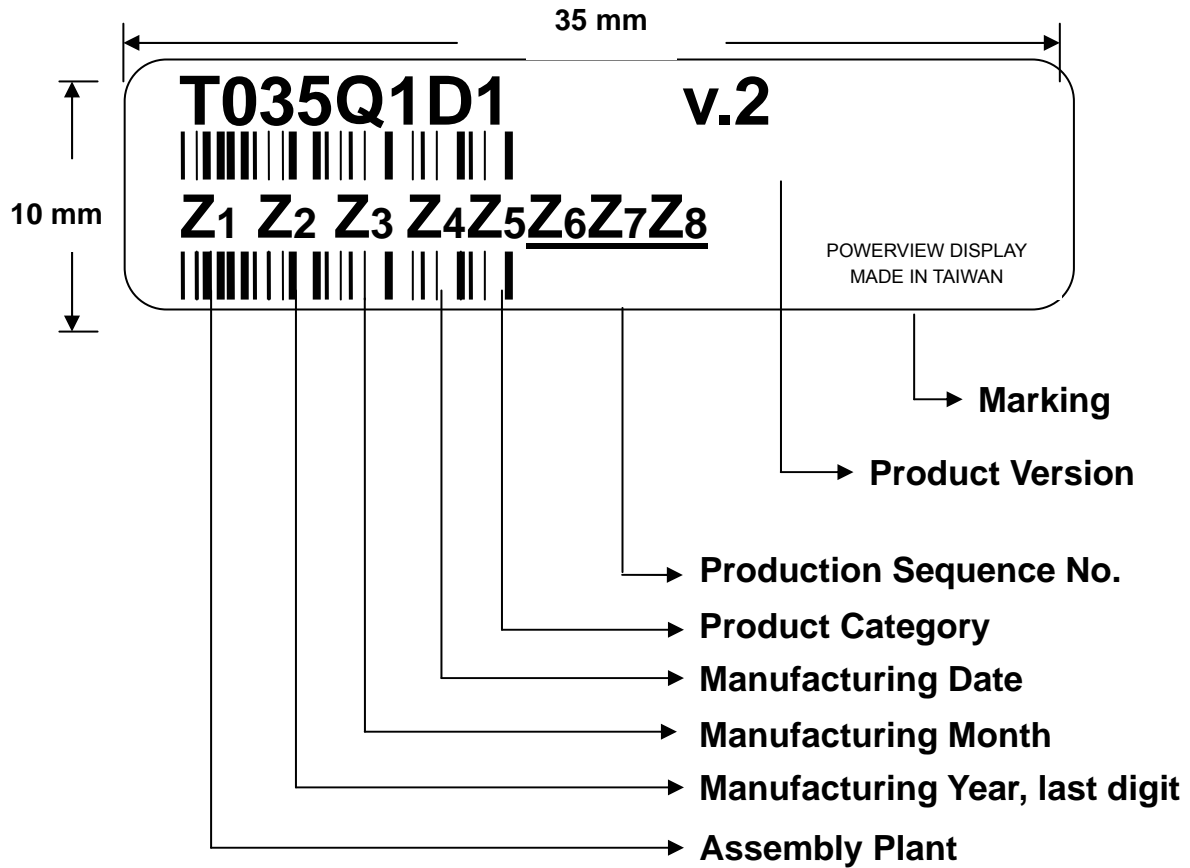

* Packaging

- TBD

* Others



9.0 General Notice

9.1 Storage

- (a) Do not leave the panel in high temperature, and high humidity for a long time. It is highly recommended to store the module with temperature from 0 to 35°C and relative humidity of less than 70%.
- (b) Do not store the TFT-LCD module in direct sunlight.
- (c) The module shall be stored in a dark place. It is prohibited to apply sunlight or fluorescent light during the storage.

9.2 Operation

- (a) Do not connect, disconnect the module in the "Power On" condition.
- (b) Power supply should always be turned on/off by the item 3.2 "Electrical Absolute Ratings"
 - * **Others**
 - (a) The liquid-crystal is deteriorated by ultraviolet rays. Do not leave it in direct sunlight and strong ultraviolet rays for many hours.
 - (b) Avoid condensation of water. It may result in improper operation or disconnection of electrode.
 - (c) Do not exceed the absolute maximum rating value. (the supply voltage variation, input voltage variation, variation in part contents and environmental temperature, and so on) Otherwise the panel may be damaged.
 - (d) If the panel displays the same pattern continuously for a long period of time, it can be the situation when the image "Sticks" to the screen.
 - (e) This panel has its circuitry FPC on the bottom side and should be handled carefully in order not to be stressed.