



# *Embedded System*

## *SPECIFICATION DATA SHEET*

**MODEL NO. : ESM070-IA9521-2**

**Date : 2006/06/02      version.1.0**

**Prepared by :** *Daniel Tseng*

*Daniel Tseng, Engineer, Product Development Div.*

**Approved by :** *Kelvin Hsieh*

*Kelvin Hsieh, Senior Engineer, Product Development Div.*

This Embedded System is distributed by:



Display Solution AG  
Talhofstraße 32a  
D-82205 Gilching  
GERMANY  
Fon +49 (0)8105 / 73 403 - 0  
Fax +49 (0)8105 / 73 403 - 79  
E-Mail: info@display-solution.com  
Internet: www.display-solution.com

This product specification is subject to change without any notice.



## Records of Revision

Date	Rev. No.	Summary	Page
2005/10/11	1.0	First issue	
2006/6/02	2.0	FPC extrusion dimension revised	



<b>Contents</b>	<b>Page</b>
<b>1.0 Handling Precautions</b>	<b>4</b>
<b>2.0 General Description</b>	<b>5</b>
2.1 General Application	5
2.2 Main Features	5
2.3 General Information	5
2.3.1 Display Characteristics	5
2.3.2 Mechanical Dimensions	6
<b>3.0 Absolute Maximum Ratings</b>	<b>7</b>
3.1 Absolute Ratings of Environment Requirement	7
3.2 Electrical Absolute Ratings	8
3.2.1 Entire Embedded System	8
<b>4.0 Optical Characteristics</b>	<b>9</b>
<b>5.0 Electrical Characteristics</b>	<b>12</b>
5.1 DC Characteristics	12
5.1.1 TFT-LCD Module	12
5.2.2 DC-AC Module and Backlight Unit	12
5.2 Input Terminal Pin Assignment	12
5.2.1 CN100 DC Power input and RS485	12
5.2.2 CN600 Compact Flash Card	12
5.2.3 USB 1.1 Client	13
5.2.4 Ethernet	13
5.2.5 RS232	14
<b>6.0 Characteristics of Touch Panel</b>	<b>15</b>
6.1 Operating Conditions	15
6.2 Electrical Characteristics	15
6.3 Mechanical Characteristics	15
6.4 Optical Characteristics	15
<b>7.0 Pixel Format Image</b>	<b>16</b>
<b>8.0 Outline Dimensions</b>	<b>17/18</b>
<b>9.0 Labeling, Packaging &amp; Others</b>	<b>19</b>
<b>10.0 General Notices</b>	<b>19</b>
9.1 Storage	19
9.2 Operation & Others	19



## 1.0 Handling Precaution

- 1.) Handle with care. Pay attention not to press or scratch the surface of the system screen, especially the polarizer. Do not twist or bend the whole module or any part of the system kit. It may cause un-recoverable damages to the system.
- 2.) Do not drop or bump the system kit since the LCD display of the asystem contains fragile glass components. Breakage of this portion might cause leakage of the liquid crystal sealed inside the displays. Do not touch the liquid crystal liquid in case of leakage. Flush with massive water immediately in case of contact with your skin with liquid crystal fluid and call for doctor for immediate medical treatment.
- 3.) Be sure to turn off power supply while plug or un-plug the power input connector.
- 4.) Clean up the polarizer only with soft solvent if necessary. The desirable cleaners are water, IPA(Isopropyl Alcohol) or Hexane. Do not use Ketone type materials (ex. Acetone), Ethyl alcohol, toluene, Ethyl acid or Methyl chloride. It will permanently damage the polarizer due to chemical reaction. 5.) Wipe off fluid drop immediately to prevent from possible discoloration or spots on the polarizer.
- 6.) Do not twist nor bend the system structure, even momentarily. Bending or twisting torque may likely damage the internal components of the system.
- 7.) The cold cathode fluorescent lamp in LCD contains small amount of mercury (Hg). Please refer to the design specification for application and the local regulations and environmental laws for disposal purpose.
- 8.) Protect the system from static environment to prevent from damage to the CMOS gate array IC.



## 2.0 General Description

ESM070-IA9521 series is a very compact, highly integrated embedded system that is consist of the following components.

1. 7" true WQVGA (480x234) digital TFT LCD display
2. 4-wire Resistive type Touch Panel
3. Embedded total solution with a standardized Intel XScale PXA255-200MHz embedded CPU board
4. Built-in SDRAM and DOC(Disk-on-Chip) flash memories
5. OS WinCE.Net 4.2 platform Ready

ESM070-IA9521 is a complete all-in-one embedded system that provides a ready-to-use environment for customers with a variety of applications. Its compact, power-saving computing circuitry and slim LCD modules make the whole system very suitable for portable, diagnostic and HMI(Human Machine Interface) applications. With its industrial standard function-ready and built-in OS WinCE.Net software, ESM070-IA9521 provides an easy-to-use, robust, installation-ready and risk-less environment for all users. Customers can concentrate their major engineering resources on the application software development for specific application.

In addition, another special merit of ESM070-IA9521 is its true digital TFT LCD display. With 7" in diagonal size, WQVGA 480x234 resolution, and 340 nits(typ. after touch) good brightness, its very vivid, eye-catching and crystal clear screen can perfectly present excellent pictures, icons, user interface on its 16:9 TFT screen. Everything needed for a computing display is already built into a compact and complete module and ready for immediate installation upon arrival.

The platform of ESM070-IA9521 also reserves high flexibilities to adopt future expansions of several different industrial interfaces without changing its original form factor. This merit can minimize the reinvestments of capital and engineering efforts in remaking mechanical tooling for specification changes.

### 2.1 General Applications

- Portable Devices, Compact Diagnostic Tools, Surveillance and Monitoring Equipment, Control and HMI Terminals



## 2.2 Main Features

- All-IN-ONE unit with Single DC power Supply Input
- Embedded CPU Engine
- Low Power Consumption
- Versatile I/O function
- Digital LCD Built-in
- 4-wire Touch Panel Integrated
- High Brightness
- Compact, Thin and Light Weight
- Built-in LCD DC-AC Inverter
- OS ready (WinCE.Net 4.2)

## 2.3 General Information

### 2.3.1 System & Display Characteristics

Item	Specification	Unit	Note
<b>Embedded System Platform</b>			
<b>CPU Processor</b>	Intel XScale PXA255 200MHz	1	-
<b>OS</b>	WinCE.NET 4.2		
<b>Flash Memory</b>	32 MB		DOC/Disk on Chip
<b>SDRAM</b>	64 MB		
<b>Input I/F</b>	RS485 x1, USB1.1 Client , RS232x2 10 M base Ethernet		
<b>Display System</b>			
<b>Display Type</b>	a-Si TFT LCD 7" (diagonal size)	inch	16:9
<b>Active Area</b>	154.08(H) x 86.58(V)	mm	-
<b>Number of Pixels</b>	480 (H) x 234(V)	pixel	WQVGA
<b>Pixel Arrangement</b>	RGB Vertical Stripe	-	-
<b>Brightness</b>	340	cd/m <sup>2</sup>	
<b>Viewing Angle</b>	120/100	degree	6 o'clock
<b>Display Mode</b>	Normally White	-	-
<b>Color Depth</b>	262K colors -- LCD 64K colors -- System		64 K colors
<b>Touch Panel Solution</b>	4 wire resistive type		
<b>Entire Embedded System</b>			
<b>Outline Dimensions</b>	164.9 x 108 x 24.36 (w/o buzzer)	mm	31.1mm w/ buzzer
<b>DC power input</b>	+12	V	



### 2.3.2 Mechanical Dimensions

Item		Min.	Typ.	Max.	Unit	Note
Dimension	Horizontal	164.6	164.9	165.2	mm	
	Vertical	107.5	108	108.5		w/o touch screen's FPC
	Depth	23.9	24.4	24.9		w/o buzzer
	Depth	30.6	31.1	31.6		w/ buzzer
Weight			300		g	±10g

## 3.0 Absolute Maximum Ratings

### 3.1 Absolute Ratings of Environment Requirement

Item	Symbol	Min.	Max.	Unit	Note
Storage Temperature	Tstg	-40	+95	°C	(1)
Operation Temperature (Ambient Temperature)	Topr	-30	+85	°C	(1)

**Note (1)** Temperature and relative humidity range are shown in the figure below.

95% RH Max. ( $40^{\circ}\text{C} > T_a$ )

Maximum wet – bulb temperature at  $39^{\circ}\text{C}$  or less. ( $T_a > 40^{\circ}\text{C}$ ) No condensation.

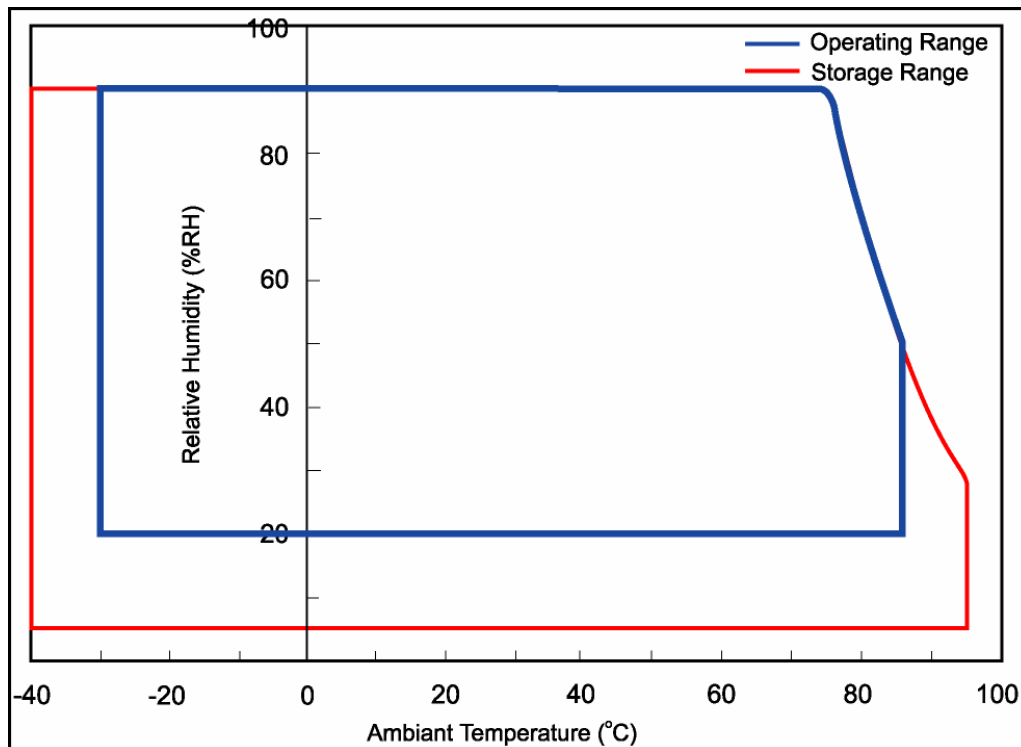



### 3.2 Electrical Absolute Ratings

#### 3.2.1 Entire Embedded Module

Item	SYMBOL	MIN	MAX	UNIT	NOTE
Power Supply Voltage	VDD	-0.3	13.2	V	(1),(2)

**Note (1)** Within operating temperature

**Note (2)** Permanent damage to the device may occur if maximum values are exceeded.

Functional operation should be restricted to the conditions described under normal operating conditions.



## 4.0 Optical Characteristics of Display

The following items are measured under stable conditions in a dark room or equivalent state.

### 4.1 Measuring Equipment: BM-5A, PR-650

( $V_{DD}=5V$ ,  $f_V=60Hz$ ,  $f_H=15.734KHz$ ,  $T_a=25\pm 2^\circ C$ )

Item		Symbol	Condition	Min.	Typ.	Max.	Unit	Note
Contrast Ratio		CR		200	300	-		BM-5A (4)-[1]
Response Time at 25°C	Rising	$T_R$		-	12	-	ms	BM-5A (5)
	Falling	$T_F$		-	18	-		
Luminance		$Y_L$	$\Phi=0$ $\theta=0$	-	340	-	Cd/m <sup>2</sup>	BM-5A (4)-[2]
Color Chromaticity (CIE 1931)	Red	$R_X$	Viewing Normal Angle		N/A			PR-650 (6)
		$R_Y$			N/A			
	Green	$G_X$			N/A			
		$G_Y$			N/A			
	Blue	$B_X$			N/A			
		$B_Y$			N/A			
	White	$W_X$		0.26	0.31	0.36		
		$W_Y$		0.28	0.33	0.38		
Viewing Angle	Hor.	$\theta_L$	CR≥10(at center point)		60		Degree	BM-5A (7)
		$\theta_R$			60			
	Ver.	$\theta_H$			40			
		$\theta_L$			60			

**Note (1)** The optical characteristics is measured with backlight.

**Note (2)** If product is exposed to high temperatures for extended time, there is a possibility of the polarizer file damage which could degrade the optical characteristics.

#### **Note (3)** Test Equipment Setup

After leaving the panel alone at a given temperature for 30 minutes under a stable condition, the measurement should be executed. Measurement should be executed in a stable, windless and dark room over 30 minutes after the backlight is lighted up. The measuring point should be at the center of screen.

-Environment condition :  $T_a=25\pm 2^\circ C$

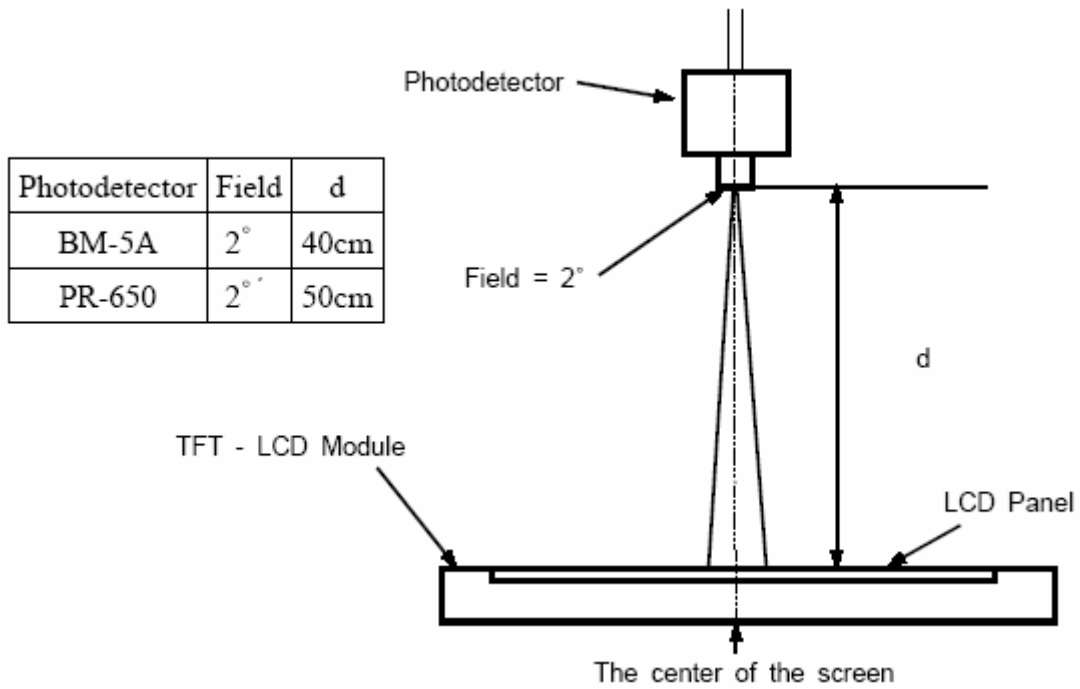

**Note (4)** Definition of Contrast Ratio, Luminance

ACTIVE AREA (H:101.76mm/ V:76.36mm)

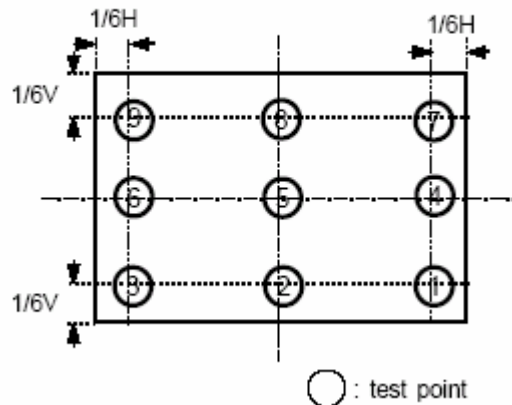

[1] Definition of Contrast Ratio (CR) : Ratio of gray max (G<sub>max</sub>), gray min (G<sub>min</sub>) at 9 points.

$$C/R = G_{max}/G_{min}$$

G<sub>max</sub> : Luminance with all pixels white

G<sub>min</sub> : Luminance with all pixels black

[2] Definition of Luminance : measure the luminance of white at center point and with I<sub>CCFL</sub>=5.0mA, after the touch panel

**Note (5)** Definition of Response Time : Sum of T<sub>r</sub> and T<sub>f</sub>.

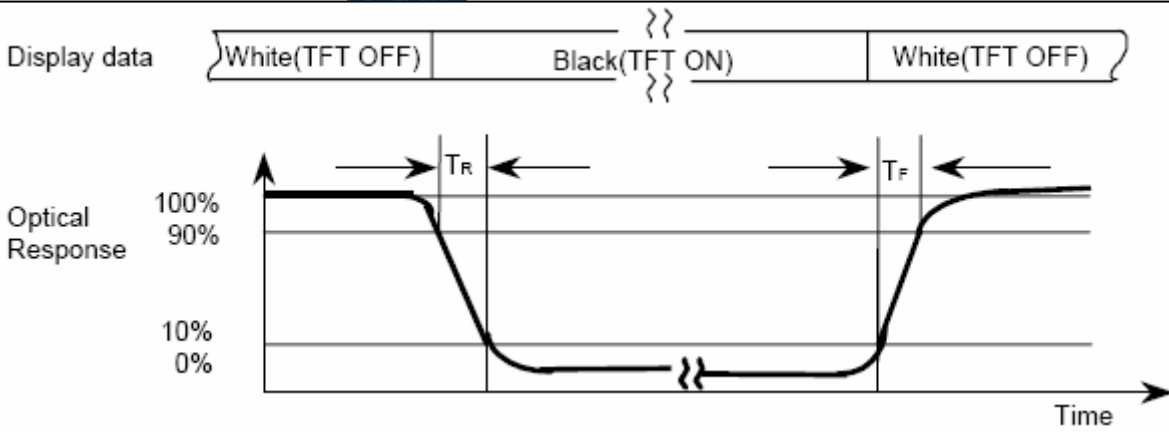

**Note (6)** Definition of Color Chromaticity (CIE 1931), (Backlight : ON) :  
Color coordinate of white at the center point

**Note (7)** Definition of Viewing Angle : Viewing angle range ( $CR \geq 10$ )

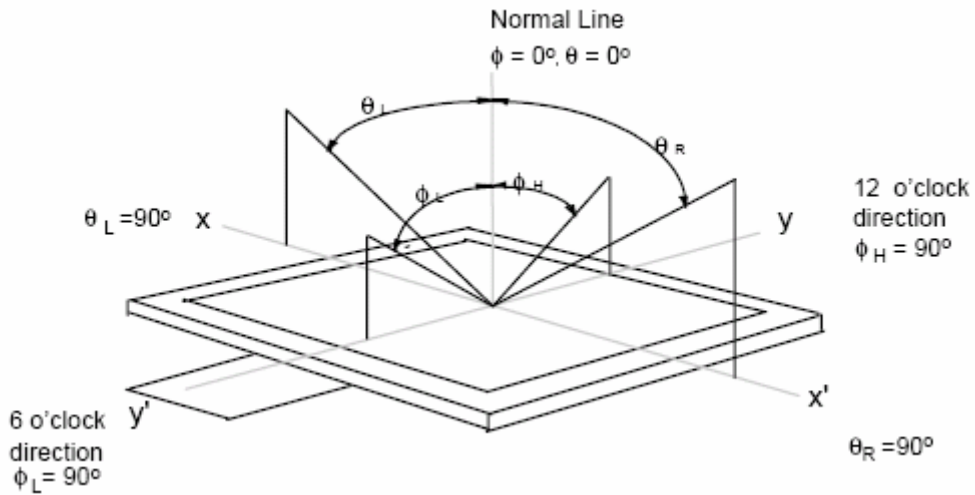



## 5.0 Electrical Characteristics

### 5.1 DC Characteristics

#### 5.1.1 Entire Embedded System

Item	Symbol	Min.	Typ.	Max.	Unit	Note
Supply Voltage	V <sub>DD</sub>	10.8	12	13.2	V	
	I <sub>DD</sub>	-	1200	1560	mA	
Permissive Input Ripple Voltage	V <sub>RF</sub>	-	-	250	mV <sub>P-P</sub>	V <sub>DD</sub> =+12V

### 5.2 Input Terminal Pin Assignment

#### 5.2.1 CN100 Power and RS485 (COM5 port)

Connector: ACES, 85204-0800, 1.25 mm pitch

Pin No	Symbol	Description	Remark
1	NC	No Connection	-
2	NC	No Connection	-
3	VDD	+12V DC input.	-
4	VDD	+12V DC input.	-
5	Data-P	RS485's Positive data terminal	COM5
6	Data-N	RS485's Positive data terminal	COM5
7	GND	Ground	-
8	GND	Ground	-

#### 5.2.2 CN600 Compact Flash Card Connector

Connector: std. CF Card Connector

Pin No	Symbol	Pin No	Symbol
1	GND	2	D03
3	D04	4	D05
5	D06	6	D07
7	*CS0	8	A10
9	*ATA SEL	10	A09
11	A08	12	A07
13	+5V	14	A06
15	A05	16	A04
17	A03	18	A02
19	A01	20	A00



21	D00	22	D01
23	D02	24	-IOCS16
25	*CD2	26	-CD1
27	D11	28	D12
29	D13	30	D14
31	D15	32	-CS1
33	*VS1	34	-IORD
35	*IOWR	36	-WE
37	INTRQ	38	+5V
39	*CSEL	40	-VS2
41	*RESER	42	IORDY
43	*INPACK	44	-REG
45	*DASP	46	-PDIAG
47	D08	48	D09
49	D10	50	GND

\* Low Active

### 5.2.3 CN700 USB1.1 Client

Connector : Standard 4 pin Mini USB , type B

Pin No.	Symbol	Description	Remark
1	Link	USB client link status indicator pin	Note 1
2	USB_CN	USB Client Negative pin	-
3	USB_CP	USB Client Positive pin	-
4	GND	Ground	-

Note 1.: When the pin is high, it means USB client port has been plugged-in USB device.

### 5.2.4 CN701 ,Ethernet

Connector : ACES, 85204-0600, 1.25 mm pitch

Pin No.	Symbol	Description	Remark
1	TX+	10M BASE-T transmit Data positive pin.	-
2	TX-	10M BASE-T transmit Data negative pin.	-
3	RX+	10M BASE-T receive Data positive pin.	-
4	NC	No Connection	-
5	NC	No Connection	-
6	RX-	10M BASE-T receive Data negative pin.	-



### 5.2.5 CN300, RS232 (COM2 and COM1 port)

Connector : ACES, 85204-0500, 1.25 mm pitch

Pin No.	Symbol	Description	Remark
1	COM2-TXD	RS232, COM2 Transmit signal pin.	-
2	COM1-TXD	RS232, COM1 Transmit signal pin.	-
3	COM2-RXD	RS232, COM2 Receive signal pin.	-
4	COM1-RXD	RS232, COM1 Receive signal pin.	-
5	GND	Ground	-



## 6.0 Characteristics of Touch Panel

### 6.1 Operating Condition

Item	Specification	Note
Operating Voltage	5V DC	7V DC max.
Operating Current	20mA max	

### 6.2 Electrical Characteristics

Item		Specification	Note
Resistance btw Terminal	XT-XB	200 ~ 900 Ω	
	YR-YL	200 ~ 900 Ω	
Insulation Resistance	X-Y	20 MΩ min.	at 25V Dc
Linearity	X	±1.5% max.	(Note 1)
	Y	±1.5% max.	
Chattering		10 ms max.	

### 6.3 Mechanical Characteristics

Item		Specification	Note
Pen Input Pressure		≤ 100 gf	R0.8, Polyacetal Pen
Finger		≤ 100 gf	R8.0 Silicon Rubber
Surface Hardness		3H min.	JISK 5400
FPC Tail		50.0±1.0 mm, pitch 1.0mm	from touch panel edge, 4 pins

### 6.4 Optical Characteristics

Item		Specification	Note
Transmittance		80% min.	



## 7.0 Display Pixel Format

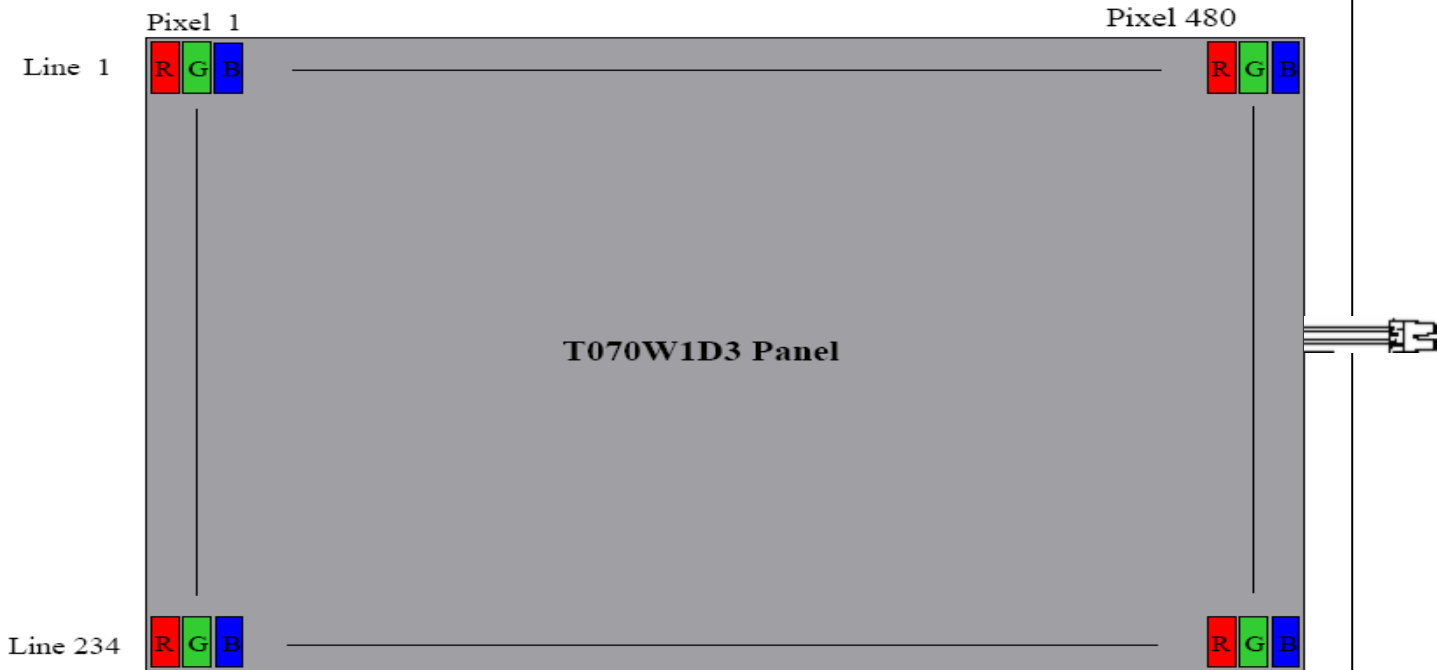

## 8.0 Outline Dimensions

### 8.1 Monitor Outline Dimensions

- Please refer to the next page

General Tolerance is 0.3 mm

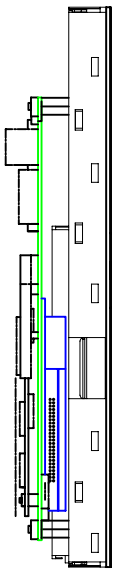
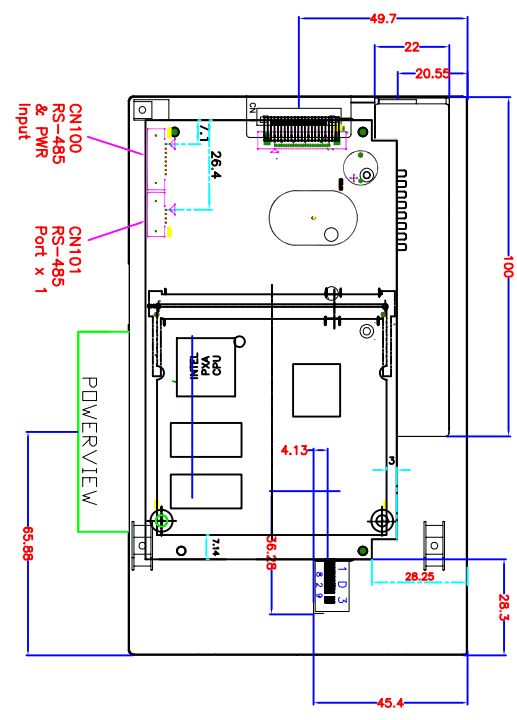
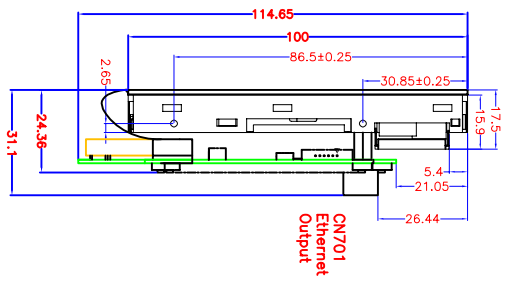
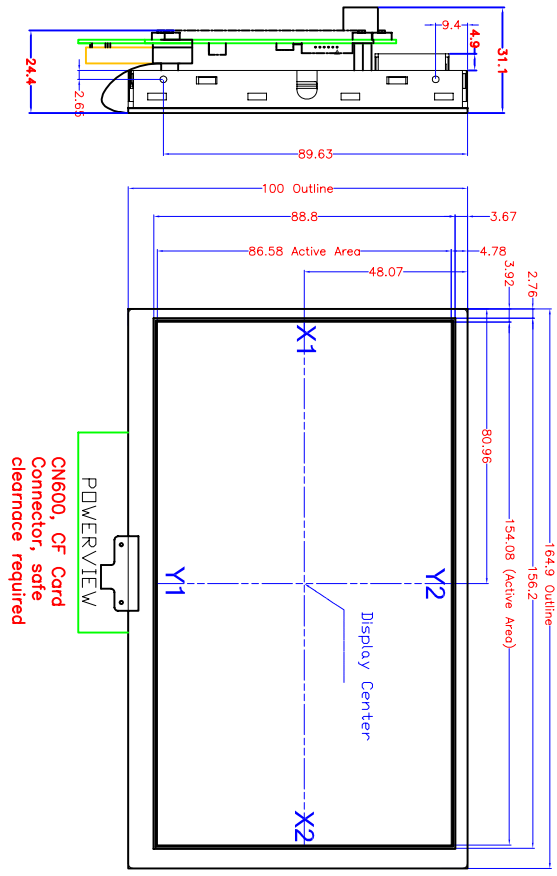
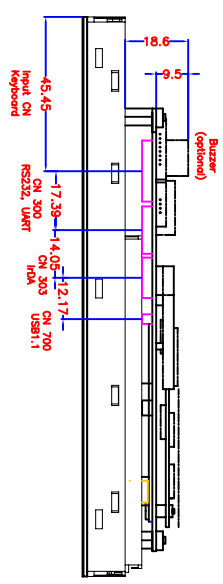

REV	EC NUMBER	DESCRIPTION	DATE
1	XXXXXX	XXXXXX	2002/02/10

DATE	1/8	GENERAL DIMENSIONS	UNIT	MM	CONVERSION	1:1	3RD ANGLE	ISO
APPROVED	2	FINISH	2	APPROVED	2	FINISH	2	APPROVED
CHECKED	2	DESIGNED	2	CHECKED	2	DESIGNED	2	CHECKED
DATE	2005/06/02	DATE	2005/06/02	DATE	2005/06/02	DATE	2005/06/02	DATE

1 2 3 4 5 6 7 8 9 10 11 12

F E D C B A

## 8.0 Labeling, Packaging & Others

### \* Labeling

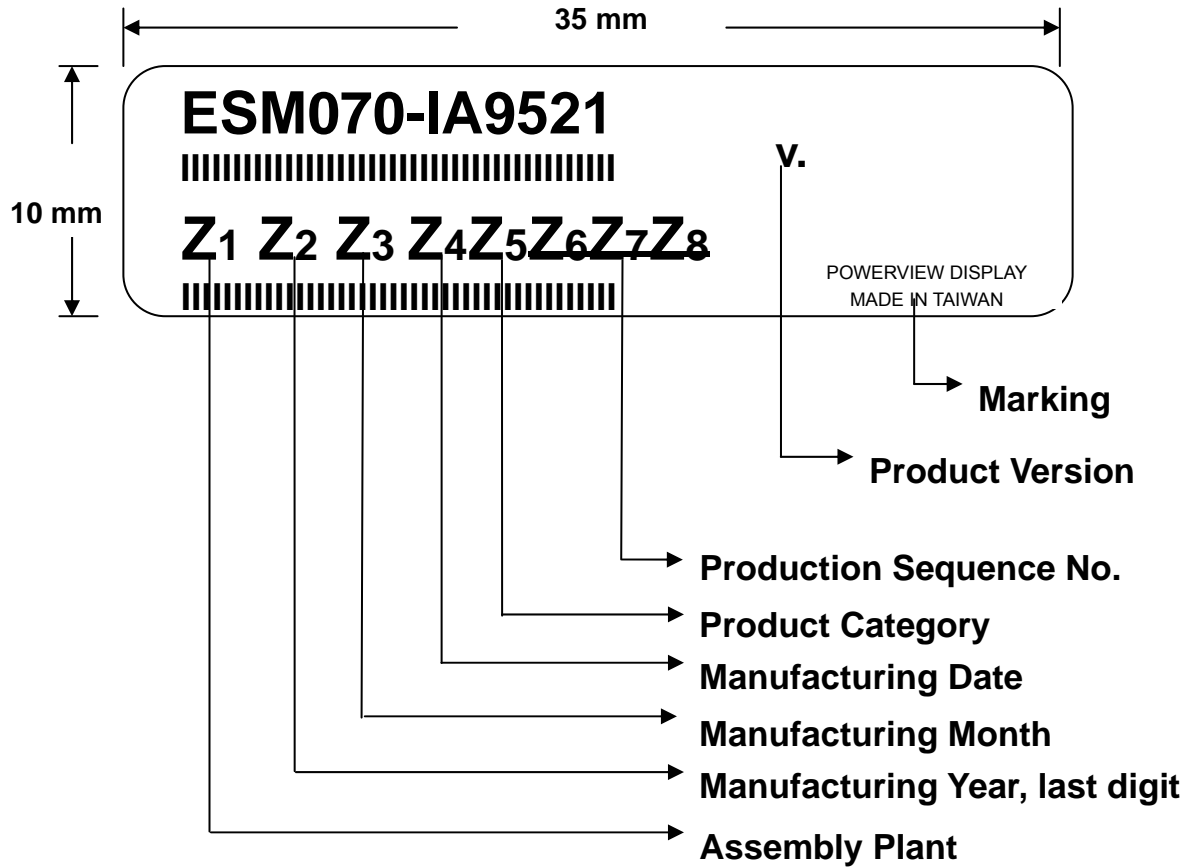

### \* Packaging

- TBD

### \* Others



## 9.0 General Notice

### 9.1 Storage

- (a) Do not leave the system in high temperature, and high humidity for long period.  
It is highly recommended to store the module with temperature from 0 to 35°C and relative humidity of less than 70%.
- (b) Do not store the system under direct sunlight.
- (c) The system shall be stored in a dark place. It is prohibited to apply sunlight or fluorescent light during the storage.

### 9.2 Operation

- (a) Do not connect, disconnect the module in the "Power On" condition.
- (b) Power supply should always be turned on/off by the item 3.2 "Electrical Absolute Ratings"
- \* **Others**
  - (a) The liquid-crystal is deteriorated by ultraviolet rays. Do not leave it in direct sunlight and strong ultraviolet rays for many hours.
  - (b) Avoid condensation of water. It may result in improper operation or disconnection of electrode.
  - (c) Do not exceed the absolute maximum rating value. (the supply voltage variation, input voltage variation, variation in part contents and environmental temperature, and so on)  
Otherwise the panel may be damaged.
  - (d) If the panel displays the same pattern continuously for a long period of time, it can be the situation when the image "Sticks" to the screen.
  - (e) This panel has its circuitry FPC on the bottom side and should be handled carefully in order not to be stressed.